



DLHA503

Curved rod arms extend 18" (46cm).
 Uses 50W MR16 bulb (EXN-CG)
 included. C/w 12' (366cm) cord, in-
 line switch and grounded plug-in
 transformer.

Bulb installation

Use only EXN-CG type 50W max.,
 c/w covered glass.
 Screws "D" holding bulb pins
 must be loosened to remove
 bulb & then tightened.
 Do not remove or replace bulb
 without loosening these screws.

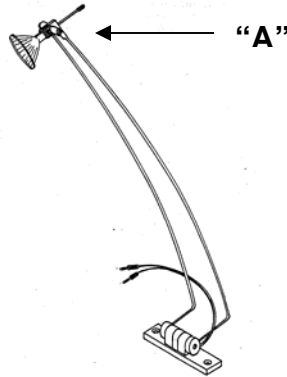

WARNING

Screw "A" must always be snug.
 Failure to do so will cause arcing and burn out
 the socket.

Do not cross antennas!
 This will cause the transformer to burn out!

**Failure to follow these instructions
 will void warranty**

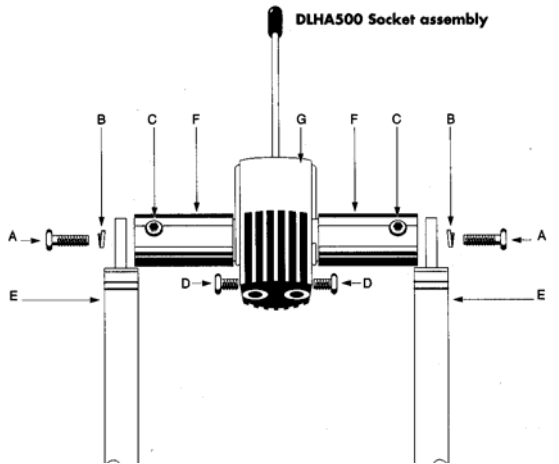

To install or remove screw "A", the set screw
 "C" must be loosened (allen key not provided).
 Screw "A" will not loosen or tighten without first
 loosening set screw "C". If you try to tighten
 screw "A" without loosening set screw "C" you
 will break arm "F" from base of socket "G".
 Breakage of arm "F" is not covered under
 warranty.

Screw "A" must be tightened firmly on both
 sides. Once this is done, tighten set screw "C".
 This locks-down screw "A" and will not allow it
 to loosen easily. Be sure lock washer "B" is in
 the proper position before tightening screw "A".
 If the socket (when bulb is installed) will not
 hold the position it is rotated to, screws "A" are
 not tight enough.