

THIS SPACE FOR DESIGNER/ ENGINEER APPROVAL

Job/Customer _____ Date _____ Contractor _____

Model Specified _____ Qty _____ Approved By _____

Designer/Engineer _____ Date _____ Contractor's PO# _____

Submitted by _____ Date _____ Other _____

5041 Series & 5041HV

**FULL PORT FORGED BRASS
UNI-FLANGE BALL VALVES
W/ HI-FLOW HOSE DRAIN, BONUS WING
STYLE "T" HANDLE, NUTS & BOLTS
SWT x FLANGE
600 WOG - ISO 9001:2000**



**The Only Way To
Isolate Circulator Pumps**

ITEM #	SIZE	P/CARTON	P/CASE	A	B	C	D	E	F	G	H	I	L
50413	3/4"	2	20	3/4	3 3/4	2 1/4	4	3/8	1/2	1	2 11/16	4 3/16	1/2
50414	1"	2	20	1	3 15/16	2 5/8	4 5/8	3/8	1/2	1 1/4	2 11/16	4 3/16	1/2
50415	1 1/4"	2	20	1 1/4	4 1/4	3	4 5/8	3/8	1/2	1 9/16	2 11/16	4 3/16	3/4
50416	1 1/2"	1	10	1 1/2	5 1/2	3 1/4	5 1/2	3/8	1/2	1 15/16	2 11/16	4 3/16	3/4
50414HV	1"	2	20	1	3 15/16	2 5/8	4 5/8	3/8	5/8	1 1/4	2 11/16	4 3/16	1/2
50415HV	1 1/4"	2	20	1 1/4	4 1/4	3	4 5/8	3/8	5/8	1 9/16	2 11/16	4 3/16	3/4
50416HV	1 1/2"	1	10	1 1/2	5 1/2	3 1/4	5 1/2	3/8	5/8	1 15/16	2 11/16	4 3/16	3/4
50417HV	2"	1	10	2	5 1/2	3 1/4	5 1/2	3/8	5/8	1 15/16	2 11/16	4 3/4	3/4

PATENTED DESIGN

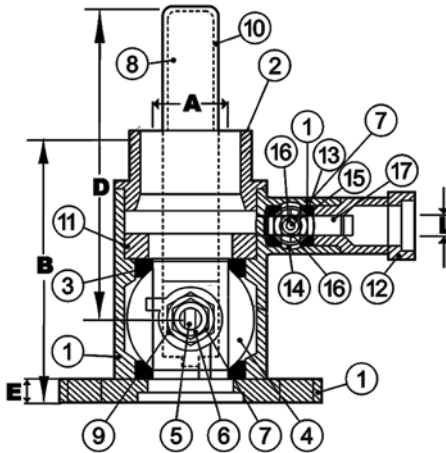
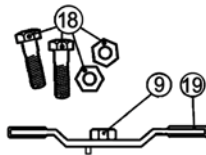

NO.	DISCRIPTION	MATERIAL
1	FLANGED BODY	BRASS
2	END CAP	BRASS
3	SEATS	PTFE
4	BALL	BRASS HCP
5	STEM	BRASS
6	STEM SEAL	PTFE
7	PACKING GLAND	BRASS
8	LEVER HANDLE	CP STEEL
9	HANDLE NUT	BRASS
10	HANDLE JACKET	VINYL
11	SEAT RETAINER	BRASS
12	DRAIN VALVE	BRASS
13	DRAIN VALVE SEATS	PTFE
14	DRAIN VALVE BALL	BRASS HCP
15	DRAIN VALVE STEM	BRASS
16	DRAIN VALVE STEM SEAL	PTFE
17	DRAIN VALVE HANDLE	ENAMEL COATED ALUMINUM
18	FLANGE BOLTS AND NUTS	STEEL
19	WING STYLE "T" HANDLE	CP STEEL W/ VINYL GRIPS

FLANGE FOR REGULAR MODELS

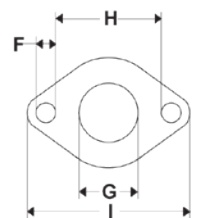

FLANGE FOR HIGH VELOCITY PUMP MODELS

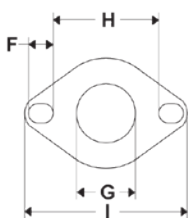

TEMP °F	WOG
100	600
150	485
200	395
250	210
300	N/A
350	N/A
366	N/A

Specifications: Designed for residential, commercial or industrial use with water, oil or gas. This approved Webstone Valve is actuated by a blowout proof stem and features an adjustable packing nut. Solder joint temperature ratings are per ASME B16.18 Annex A for 95-5 solder. Other solder materials have lower pressure/temperature limits. Do not silver braze or over heat valves when soldering.

Webstone Company, Inc.
www.webstonevalves.com

Quality and Commitment Since 1954

Tel: (800) 225-9529 • Fax (800) 336-5133

Webstone product specifications in U.S. customary units are approximate and are provided for reference only. Webstone reserves the right to change or modify product design, construction, specifications or materials without prior notice and without incurring any obligation to make such changes and modifications on Webstone products previously or subsequently sold. The Isolator® is a registered trademark of Webstone Company, Inc.