

This Space for Architect/Engineer Approval

Job Name _____ Date _____
 Model Specified _____ Quantity _____
 Customer/Wholesaler _____
 Contractor _____
 Architect/Engineer _____

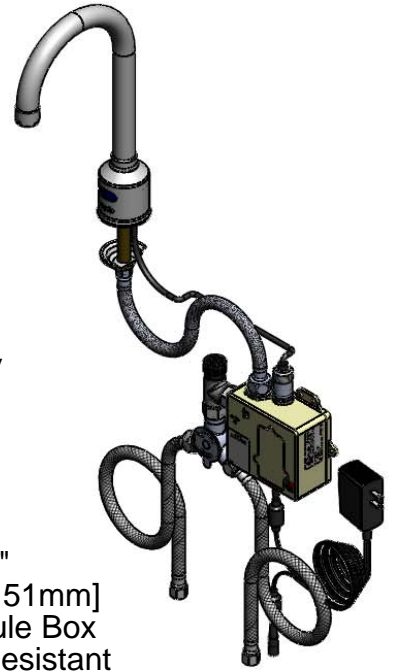

ADA Compliant



Rigid Gooseneck w/ 2.2 GPM [8.3 LPM] Vandal Resistant Aerator & Key

5EF-0004
24" [610mm] Sensor Cable

5EF-0001
3 5/8" x 4 3/16" x 2" [92mm x 106mm x 51mm] Deep Control Module Box (White) w/ Water Resistant Connections. AC or DC Operated w/ (4) AA Batteries

016297-45
Furnished w/ 1/4" NPSM Female x 1/2" NPSM Female x 18" [457mm] Long Flexible Stainless Steel Hose.

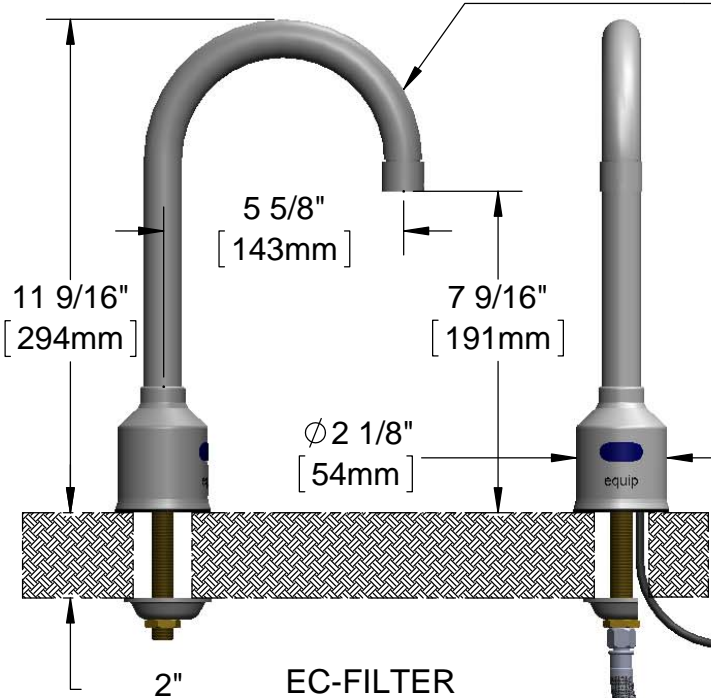

2" [51mm] Maximum Thickness
 EC-FILTER Removable Strainer
 5EF-0006 Mechanical Mixing Valve w/ Integral Check Valves
 5EF-0005 (2) 18" [457mm] Flexible Stainless Steel Supply Hoses: 1/2" NPSM Female x 3/8" Compression Female

Socket Wrench

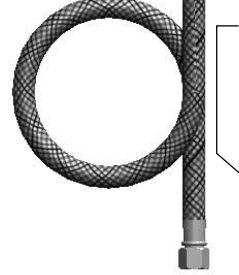
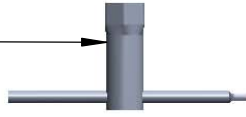

015425-45
Vandal Resistant Key

5EF-0002
144" [3658mm] Long Power Cord w/ 100-240 VAC Adapter (Remove Rubber Plug in Module to Connect.)

Note: Rough-In Requirement
 Ø 1" [25mm] Mounting Hole

Model Number 5EF-1D-DG	Date 09/30/11	Scale 1:4	Drawn DHL	Checked DMH	Approved JHB
----------------------------------	-------------------------	---------------------	---------------------	-----------------------	------------------------

Product Specifications:
 Electronic Faucet: Deck Mount, Rigid Gooseneck w/ VR 2.2 GPM Aerator, Temperature Control Mixing Valve w/ Integral Check Valves, (2) 18" Long Flexible Supply Hoses & AC-DC Control Module



equip Foodservice Accessories
 2 Saddleback Cove, P.O. Box 1088
 Travelers Rest, South Carolina 29690
 Phone: 800.891.4808 Fax: 800.868.0084

ITEM NO.	SALES NO.	DESCRIPTION
1	015425-45	Vandal Resistant Key
2	B-0199-06	VR Aerator w/ Key
3	5EF-0004	24" Sensor Cable
4	016297-45	Inlet Hose, Faucet, 1/2" NPSM-F x 1/4" NPSM-F
5	5EF-0001	equip Sensor Faucet - Control Module
6	5EF-0002	Equip AC Transformer, 100-240 VAC
7	5EF-0005	Supply Hose, 9/16-24 Female x 1/2" NPSM
8	5EF-0006	Mechanical Mixing Valve
9	EC-FILTER	Replacement Filter

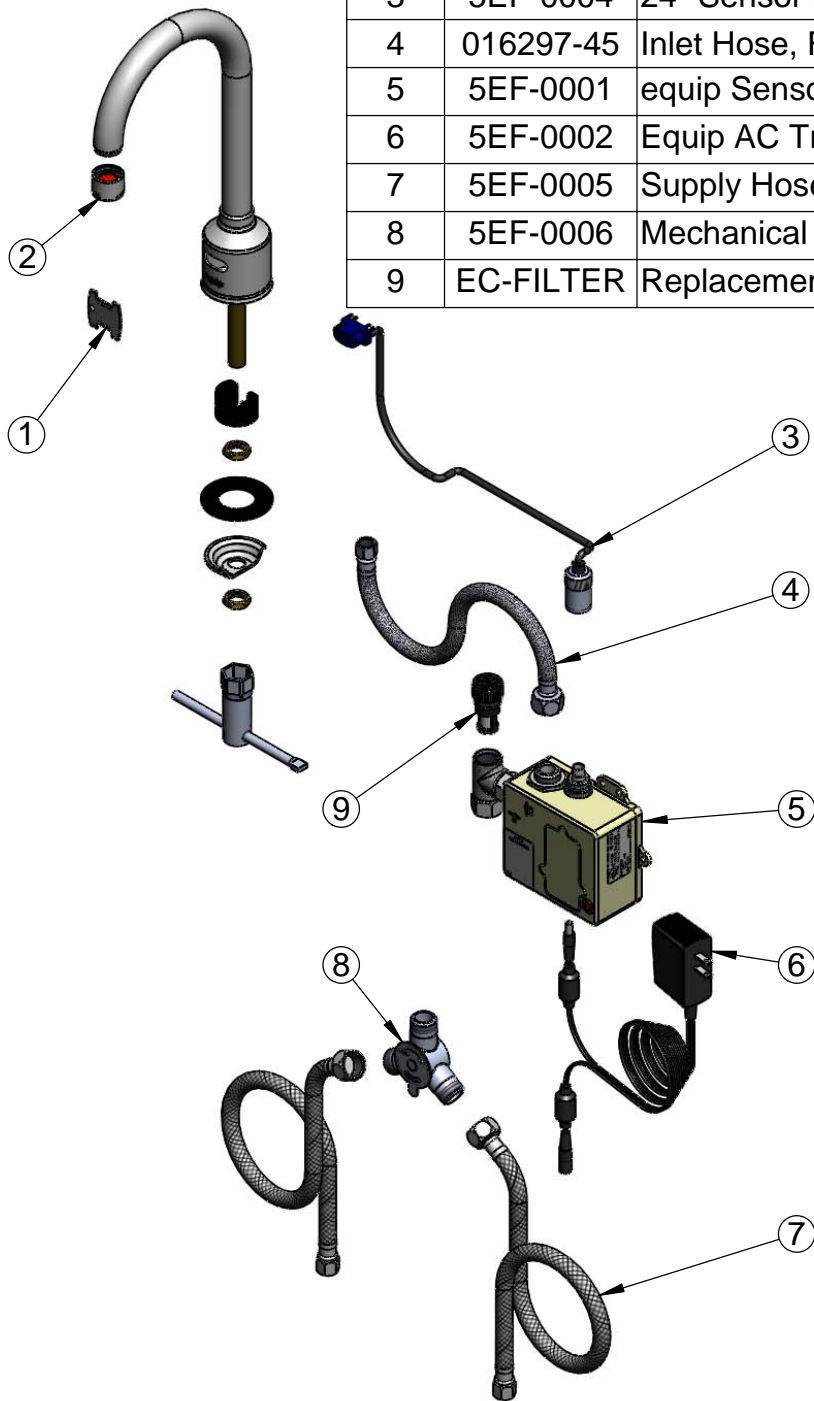

Model Number 5EF-1D-DG	Date 09/30/11	Scale NTS	Drawn DHL	Checked DMH	Approved JHB
---------------------------	------------------	--------------	--------------	----------------	-----------------



Product Specifications:
 Electronic Faucet: Deck Mount, Rigid Gooseneck w/ VR 2.2 GPM Aerator, Temperature Control Mixing Valve w/ Integral Check Valves, (2) 18" Long Flexible Supply Hoses & AC-DC Control Module

equip Foodservice Accessories
 2 Saddleback Cove, P.O. Box 1088
 Travelers Rest, South Carolina 29690
 Phone: 800.891.4808 Fax: 800.868.0084