

# SPEAKMAN®

## Caspian™ Pressure Balance Valve and Trim

SM-7000-P

SPECIFICATION

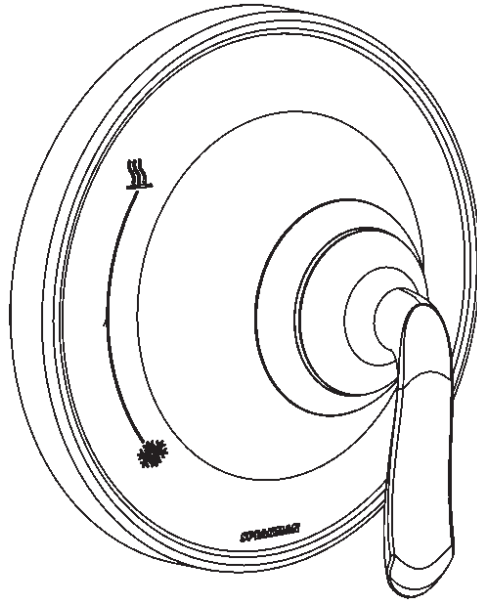

### FEATURES:

#### VALVE:

- Anti-scald pressure balance valve
- Built-in check valves
- Pressure balancing and ceramic temperature regulating cartridge
- Adjustable temperature limit stop
- Integral stops
- ½" NPT female tub outlet
- ½" sweat shower outlet
- ½" sweat inlets
- Includes rough-in template

#### TRIM:

- Contemporary style
- Mounting plate with seal
- Metal handle
- Durable plastic trim plate



#### COMPLIANCE:

- ASME A112.18.1/CSA B125.1 certified
- ASSE 1016 certified

#### FINISHES:

ADD SUFFIX TO MODEL #

- Polished Chrome (standard)
- Brushed Nickel  -BN

#### WARRANTY:

- 1 year limited

SEE REVERSE FOR ROUGH-IN DIMENSIONS

THIS SPACE FOR ARCHITECT/ENGINEER APPROVAL.

# SPEAKMAN®

400 ANCHOR MILL ROAD | NEW CASTLE, DE 19720  
P: 800-537-2107 | F: 800-977-2747  
WWW.SPEAKMANCOMPANY.COM

REVISION DATE: SEPTEMBER 2014



Management Systems  
Registered to ISO 9001

# SPEAKMAN®

## Caspian™ Pressure Balance Valve and Trim SM-7000-P

SPECIFICATION

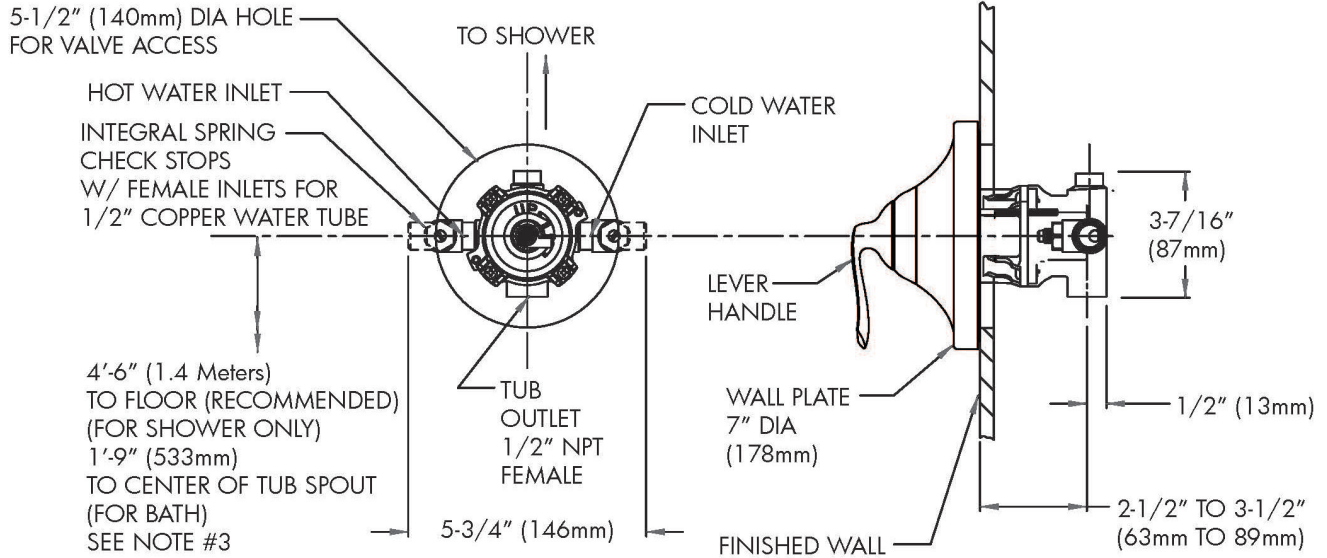
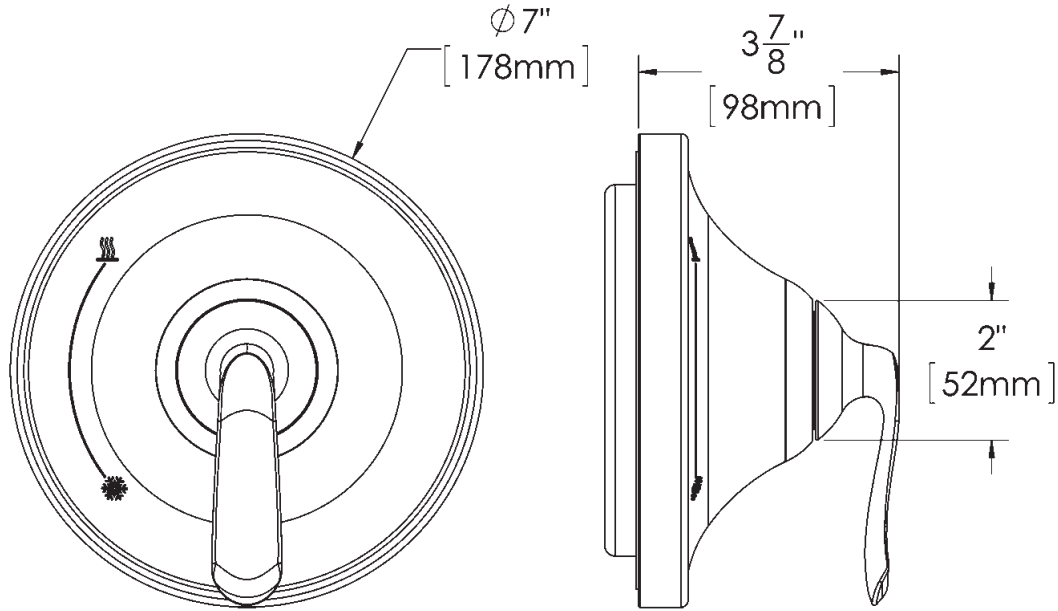

NOTE: 1. All dimensions are in inches (millimeters) unless otherwise specified and are subject to change without notice. 2. Unless otherwise specified, all inlets and outlets are 1/2" female copper sweat. 3. For ADA mounting locations, consult ADAAG, ANSI A117.1, or static regulations.

THIS SPACE FOR ARCHITECT/ENGINEER APPROVAL.

# SPEAKMAN®

400 ANCHOR MILL ROAD | NEW CASTLE, DE 19720  
 P: 800-537-2107 | F: 800-977-2747  
 WWW.SPEAKMANCOMPANY.COM



Management Systems  
 Registered to ISO 9001

REVISION DATE: SEPTEMBER 2014