

► **Description**

Wall hung, wall outlet, Waterfree Vitreous China Urinal.

► **Features**

- Touch-free operation
- Uses no water
- Mechanical-free design
- Patented, Sealed Locking Cartridge
- Smooth, non-porous surfaces

► **Benefits**

- Improved hygiene and safety
- Reduced water and sewer costs
- Water supply piping not required
- Odor-free
- Vandal resistant
- Minimal care and easy cleaning

► **Specifications**

Wall hung, wall outlet, waterfree, Vitreous China Urinal with the following features:

- Vitreous China Fixture
- Housing (H-1-1.5-M3)
- Cartridge Kit † — Engineered to last for at least 7000 uses
- Two Wall Hanger Brackets Included
- Uni-coupler (for new and retrofit installations)
- Tube of Adhesive Caulking

† Additional Cartridges sold separately

► **Colors**

- Standard White

Consult factory for optional colors.

► **Cartridge Filter**



**Patented, Sealed Cartridge uses a Biodegradable Sealant Liquid to control odors.**

The Cartridge is engineered to last for at least 7000 uses and to receive waste through drain holes. Waste passes through an emissible layer of Sealant, continues through a Siphon Trap System, and flows out through a Patented Baffle to prevent the loss of Sealant. A Discharge Tube in the housing directs the flow of waste into the building drain system. The Cartridge is designed as a replaceable component when its function has been exhausted.



Featuring Falcon Waterfree Technology



**The New Sloan Waterfree Urinal —  
Preserves our Natural Resources and  
saves costs**

Sloan Waterfree Urinals reduce water and sewer costs, maintenance and repair bills, and create more hygienic, odor-free restrooms. A Patented, Sealed Cartridge eliminates the need for water, typically conserving 40,000 gallons per unit per year. Installing Waterfree Urinals along with other Sloan Conservation Products ensures meaningful water savings. In addition, Sloan Waterfree Urinals do not require costly piping to fixture.

ANSI/ASME A112.19.2.M-1998 and A117.1 (Section 605.2)  
IAPMO 1GC 161-2000 and ANSI Z124.9-94



MEETS THE AMERICAN DISABILITIES ACT  
GUIDELINES AND ANSI A117.1  
ACCESSIBLE AND USABLE BUILDINGS  
AND FACILITIES - CHECK LOCAL CODES.



This space for Architect/Engineer approval	
Job Name _____	Date _____
Model Specified _____	Quantity _____
Variations Specified _____	
Customer/Wholesaler _____	
Contractor _____	
Architect _____	

► **Description**

Wall hung, wall outlet, Waterfree Vitreous China Urinal.

► **Dimensions**

16<sup>7</sup>/<sub>8</sub>" (429 mm) x 14<sup>5</sup>/<sub>8</sub>" (371 mm) x 24<sup>5</sup>/<sub>8</sub>" (625 mm)

► **Approximate Weight**

53 lbs.

► **Mounting For ADA Compliance**

For lip height of 17", distance from finished floor to drain centerline must be 10"

**Uni-Coupler**

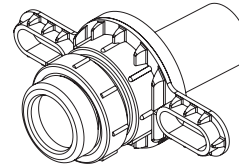

This adaptive coupler design enables the installer to connect the Uni-coupler directly onto the spud flange or in-wall nipple.

**ROUGH-IN**

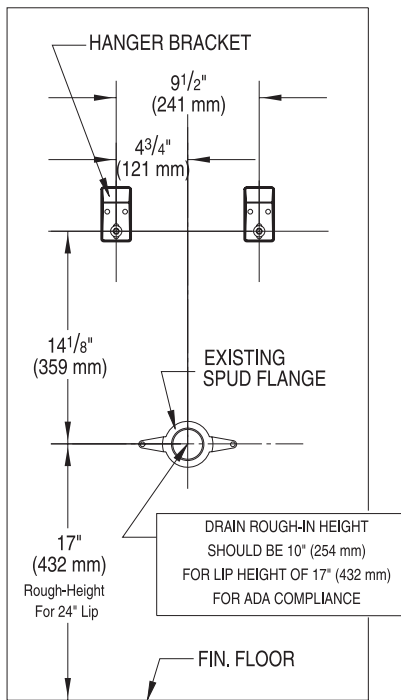

ROUGH-IN BRACKET LOCATION

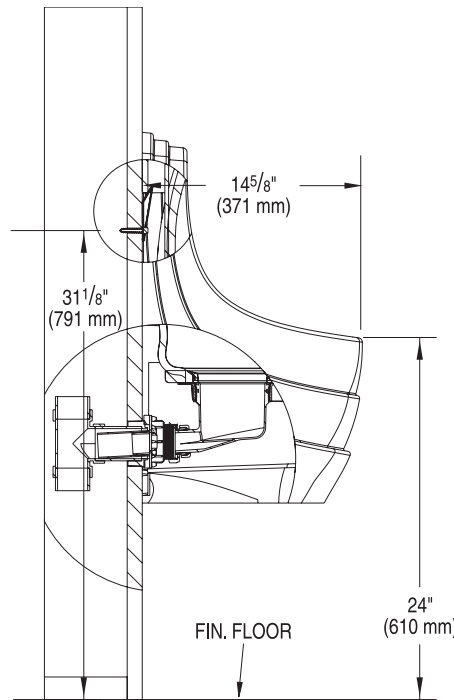

SIDE VIEW

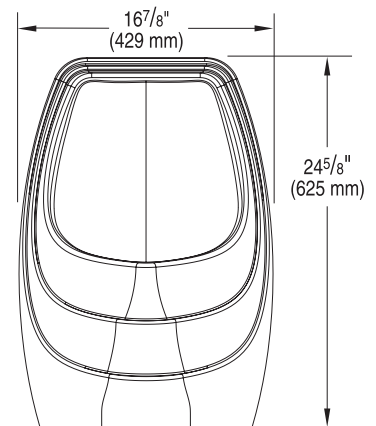

FRONT VIEW

**MAINTENANCE AND CLEANING**

- Perform cleaning once a day, or as needed
- Remove any litter in the bowl and clear cartridge holes
- Use mild disinfectant cleaner on a cloth to wipe the bowl
- DO NOT use aggressive/concentrated detergents or any other chemicals
- DO NOT dispose of water into the urinal

**SLOAN VALVE COMPANY • 10500 SEYMOUR AVENUE • FRANKLIN PARK, IL 60131**

Phone: 1-800-9-VALVE-9 or 1-847-671-4300 • Fax: 1-800-447-8329 or 1-847-671-4380 • <http://www.sloanvalve.com>