

Type _____
 -09 -20
 P4436

Catalog No.	Finish		Lamping	Dimensions (Inches)		
	Brushed Nickel	Antique Bronze		A	B	C
P4436	-09	-20	5 (c) 60w	22	26-3/8	101

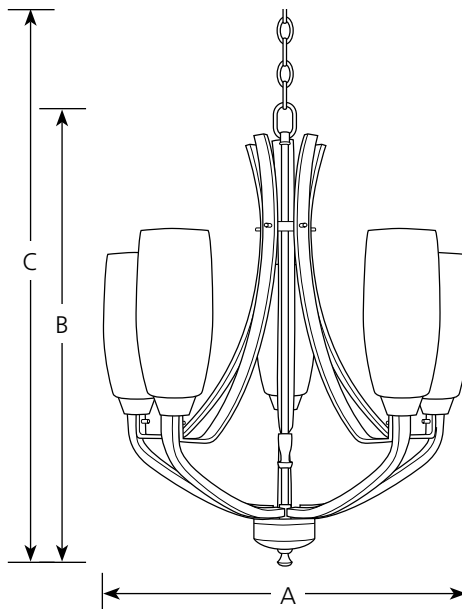

Specifications:

General

- Etched glass tulip shaped shades (4" dia., 8-1/8" ht., 1-5/8" center hole)
- Uplight style chandelier
- Strap style arms and accents
- Six feet of 9 gauge chain supplied
- Brushed Nickel (-09) is plated
- Antique Bronze (-20) is hand painted
- Steel construction
- Companion chandelier, hall and foyer, wall bracket, close to ceiling, pendant, and bath and vanity units

Mounting

- Ceiling chain mounted
- Canopy covers a standard 4" hexagonal outlet box
- Mounting strap for outlet box included

Electrical

- Phenolic candelabra based sockets
- 15 feet of wire
- Pre-wired

Labeling

- UL-CUL listed



Compact Fluorescent

Westin CFL
Energy Star

Chandelier & Foyer

Type _____
 -09EBWB -20EBWB
 P4436

Catalog No.	Finish		Lamping	Dimensions (Inches)		
	Brushed Nickel	Antique Bronze		A	B	C
P4436	-09EBWB	-20EBWB	5 13w CFL Included	22	26-3/8	101

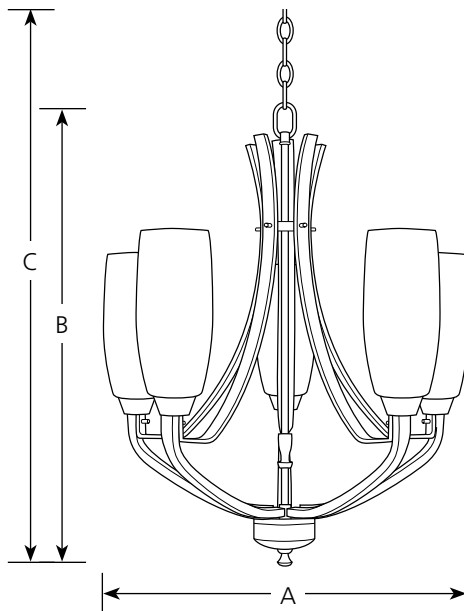

Specifications:

General

- Etched glass tulip shaped shades (4" dia., 8-1/8" ht., 1-5/8" center hole)
- Compact Fluorescent self-ballasted lamps included
- Uplight style chandelier
- Strap style arms and accents
- Six feet of 9 gauge chain supplied
- Brushed Nickel (-09) is plated
- Antique Bronze (-20) is hand painted
- Steel construction
- Energy Star certified
- Companion chandelier, hall and foyer, wall bracket, close to ceiling, pendant, and bath and vanity units

Mounting

- Ceiling chain mounted
- Canopy covers a standard 4" hexagonal outlet box
- Mounting strap for outlet box included

Electrical

- GU24 based sockets
- 15 feet of wire
- Pre-wired

Labeling

-  US listed



Progress Lighting
 701 Millennium Blvd.
 Greenville, South Carolina
 29607

www.progresslighting.com