

INDOOR WALL-MOUNT
LIGHT FIXTURE
INSTRUCTIONS
MODEL No: 16-51

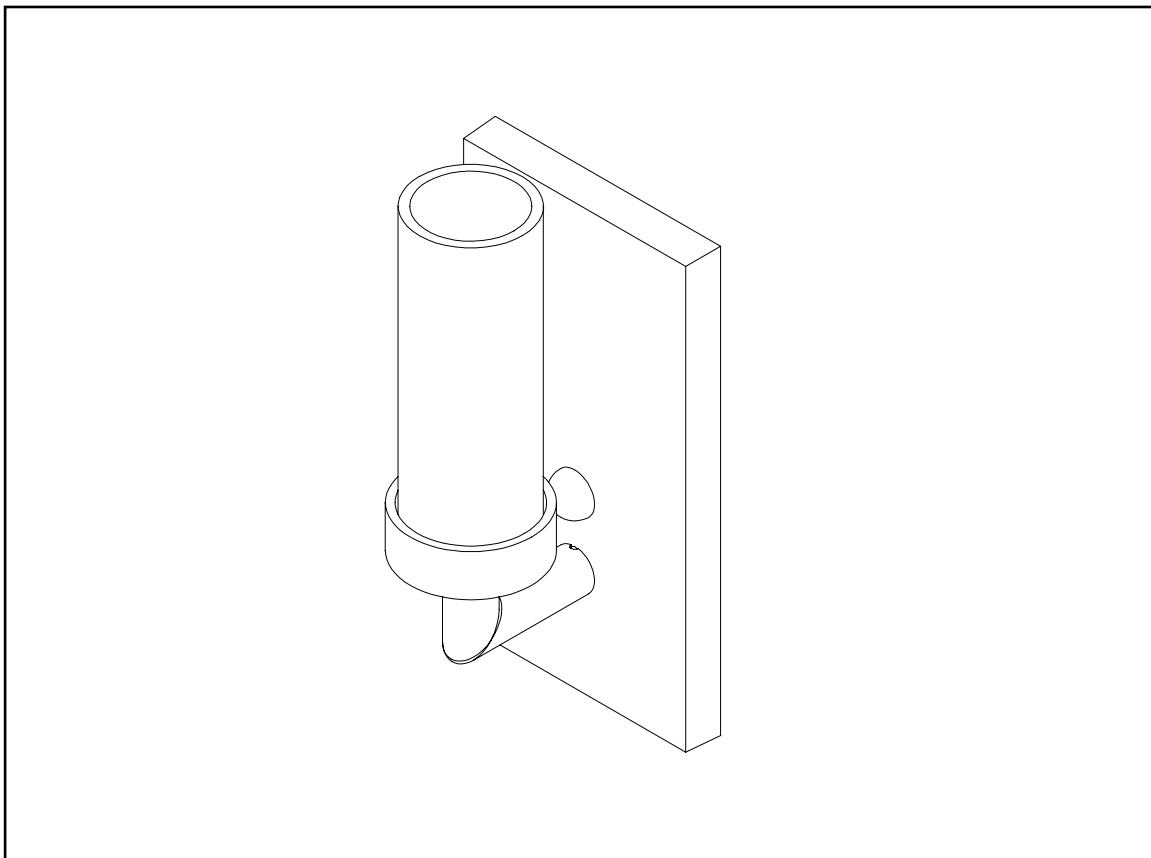

Congratulations on the purchase of this Newport Brass product, an excellent choice that will give you years of quality service and enhance the look and style of your home.

CAUTION: DISCONNECT POWER

Always shut off power when installing or repairing this, or any other electric appliance.
FAILURE TO DO SO MAY RESULT IN SEVERE INJURY OR DEATH
Installation by a licensed electrical contractor recommended.

WALL MOUNT ONLY SHADE UP INSTALLATION ONLY

1 Preparing Wall Outlet

A. Check fit the light fixture base over outlet box to ensure cutout in wall will be covered completely after installation.

B. Pull live, neutral and ground wires out of electrical outlet box.

C. Thread mounting screws through mount strap with all-thread nipple facing outward as shown and attach to outlet box.

D. Be sure mounting strap is flush with wall surface.

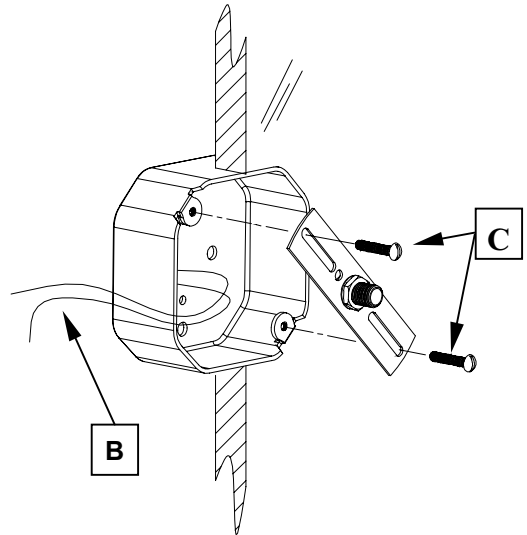

2 Wire Light Fixture to Outlet

Support Fixture during wiring process.

A. Strip, clean and twist together black fixture wire with live outlet wire. Next, strip, clean and twist together white fixture wire with neutral outlet wire. Use wire nuts to secure connections and cover all exposed wires.

B. Connect fixture/outlet ground wire(s) to mount plate using washer and ground screw.

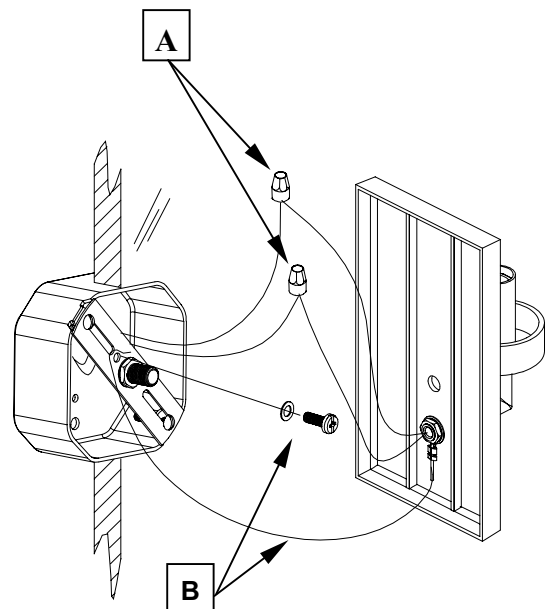

3 Mount Light Fixture to Wall

- A. Tuck wires back into the electrical outlet box behind Wall Mount strap.
- B. Insert the all-thread on mounting strap through hole in fixture and secure into place with decorative cap.
- C. After completing wall mount installation, install bulb, (Max. 60 watt, Type B, Candelabra Base . Bulb - not included).
- D. Place shade over bulb and secure by threading onto holder. Turn on power.

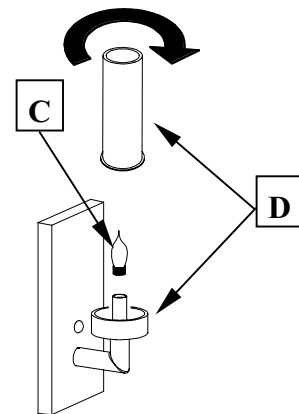
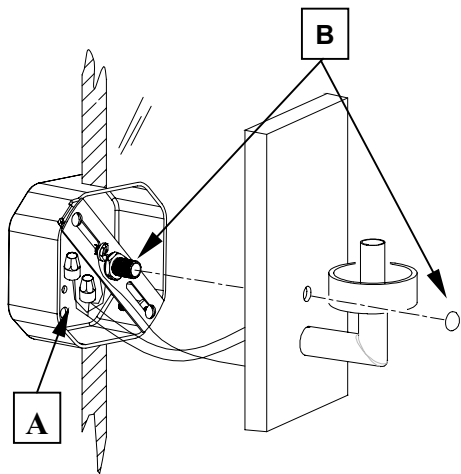

NEWPORT BRASS®

The Luxury of Style

Newport Brass Product Care

Newport Brass faucets and bath fittings are made of solid brass and are of the finest quality. To maintain the finish on these items, please:

- ü Do not use any abrasive cleaners, detergents, brass or silver polish which will scratch the surface.
- ü Clean with a soft damp cloth.

Applying a coating of a non-abrasive liquid wax to the clean surface of the product will keep it looking beautiful. Brass ProTech, a product of Brasstech, Inc., can be used on all types of decorative painted and plated finishes.

Simply apply Brass ProTech with a soft cloth and let it dry. Then remove by rubbing gently with a soft dry cloth. Brass ProTech contains no harsh abrasives.

We highly recommend using Brass ProTech on items finished in Satin Nickel (15S), Polished Nickel (15), Polished Silver (25) and Satin Silver (25S).

Do not allow soap scum or minerals in water to build up on the surface finish of your faucets or bath fittings (including toothpaste). These will gradually eat into any finish and diminish the beauty of your Newport Brass products.

Warranty

Newport Brass products are warranted to the original purchaser for a period of 10 years in all finishes except as follows: Forever Brass (01) P.V.D., Satin Bronze (10) P.V.D., Polished Chrome (26), Stainless Steel (20) P.V.D., Oil Rubbed Bronze (10B), and powder-coat colors have a lifetime warranty. Uncoated finishes such as: Uncoated Brass (03N), Weathered Brass (03W) and Weathered Copper (08W) have no finish warranty.

The warranty period starts from the date of shipment to the original purchaser. Kitchen, bath or lavatory drains of all types, due to abuse to which they may be subjected, are warranted as follows: powder-coated colors, Polished Chrome (26), Satin Chrome (26D), Oil Rubbed Bronze (10B), Forever Brass (01) or Stainless Steel (20) - 1 year. In all other finishes – no warranty on the finish for these products.

Ceramic disc valves (lavatory, tub/shower, and roman tub valves) have a lifetime warranty. Other valve types (balance pressure, thermostatic, etc.) are warranted for one year from the date of purchase on mechanical operations.

Product problems attributable to abuse, misuse, improper installation, hard water, maintenance or accidental damage are not covered by this warranty. No repairs or replacements will be made under such circumstances except at customer's expense. Liability under all warranties expressed or implied is limited to replacement of non-conforming goods only.

Flush pipes prior to installation

Solder and other debris may damage ceramic discs. Cartridges are factory set at 14–16 lbs. torque.