

SINK DESCRIPTION

- Manufactured of 20 gauge, type 301 nickel-bearing stainless steel
- The bowls are a minimum of 14" x 16" x 7-1/4"
- The sink ledge has four fixture mounting holes, 1-1/2" in diameter and 4" on center
- Has two 3-1/2" diameter recessed drain opening
- Is fully undercoated with a sound and temperature insulating material
- The exposed surfaces are polished to a lustrous satin tone finish
- Includes all necessary mounting hardware

CUT OUT DIMENSIONS

- Cut out dimensions are 32-3/8" x 21-3/8", with a 3/8" corner radius. A tolerance of plus or minus 1/16" is acceptable

STANDARDS

- Third party certified by IAPMO to meet ASME A112.19.3 and all applicable specifications referenced therein.

WARRANTY

- Warranted for ten years against material or manufacturing defects

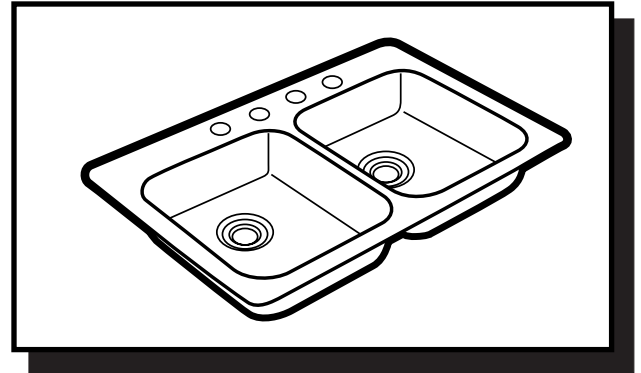

**Camelot®
Double Bowl Kitchen Sink
Model: 22218
(KDE-3322-4)**

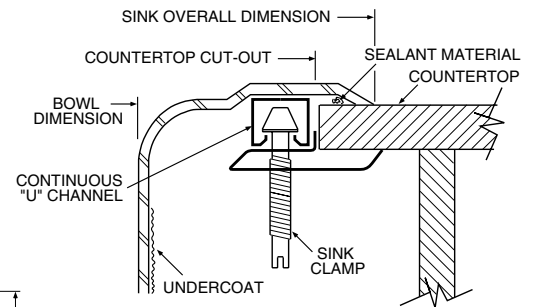

Installation Detail

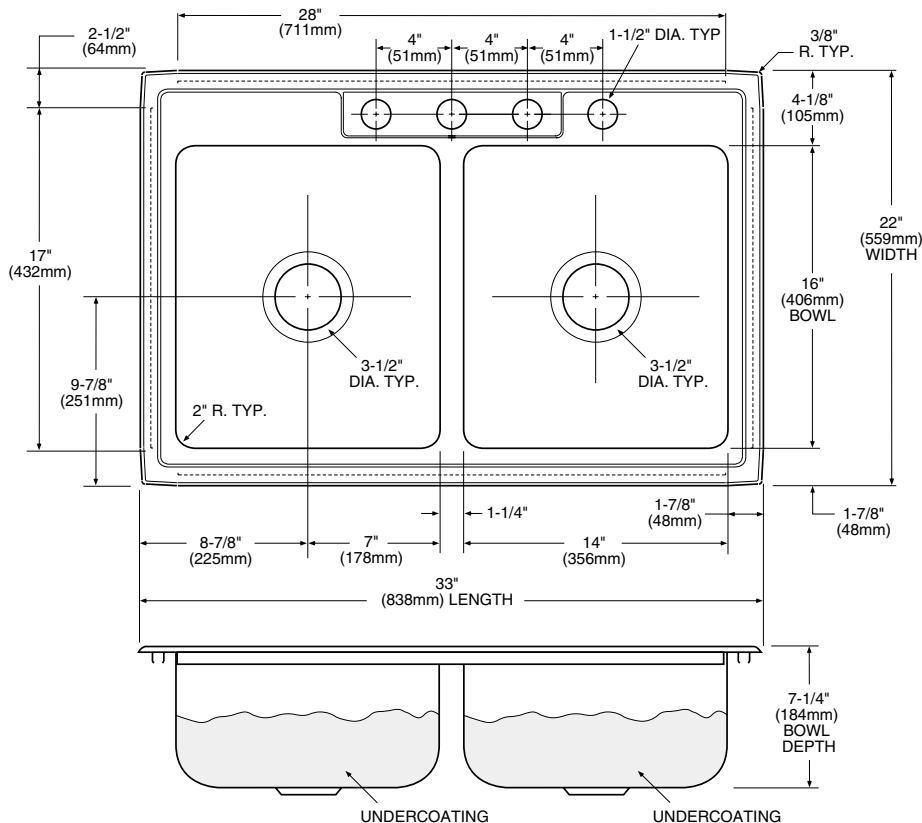

CRITICAL DIMENSIONS

(DO NOT SCALE)