

Installation Instructions / Warranty

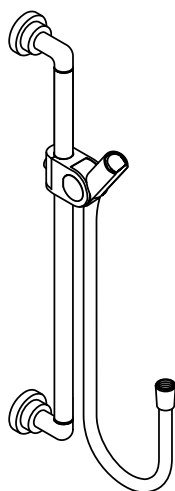

Citterio
27831XXX

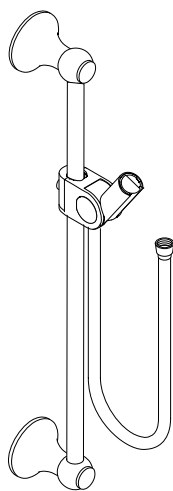

Terrano
27834XXX

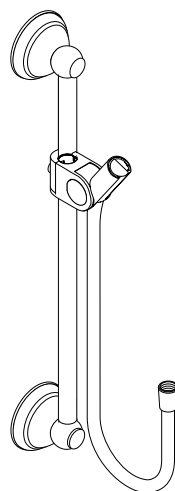

**Carlton
Phoenix**
27835XXX

AXOR[®]

hansgrohe

Axor Citterio Wallbar Set

27831XXX

Axor Terrano Wallbar Set

27834XXX

Axor Carlton / Phoenix Wallbar Set

27835XXX

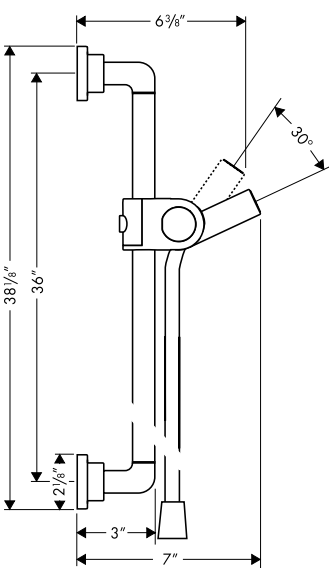

27831XXX

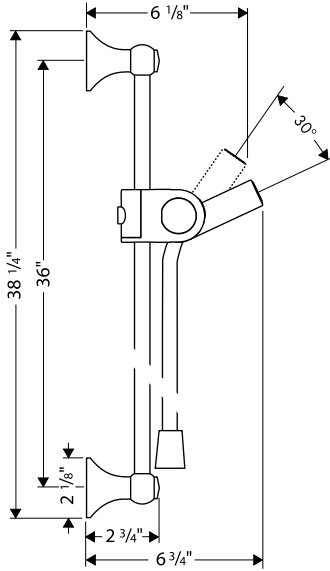

27834XXX

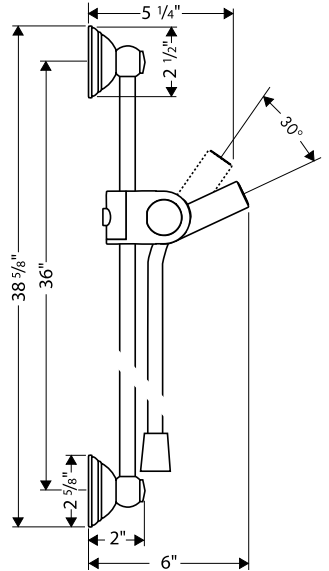

27835XXX

This wallbar set contains the wallbar and a 63" Techniflex handshower hose. It is compatible with any Hansgrohe handshower.

Axor Citterio Wallbar Installation

Mark the positions for the screw holes (1). The center of the top hole should be 36" from the center of the bottom hole.

Drill the holes with a 6 mm bit suitable for the wall surface (2).

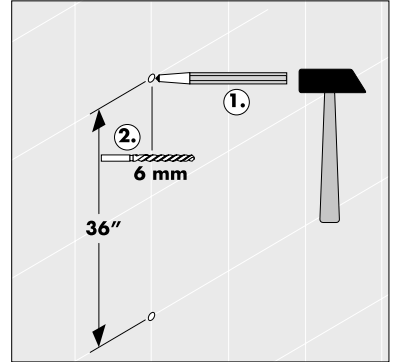

Install the anchors. Seal the wall around the anchors with waterproof sealant.

Install the mounting pieces with the screws and metal washers.

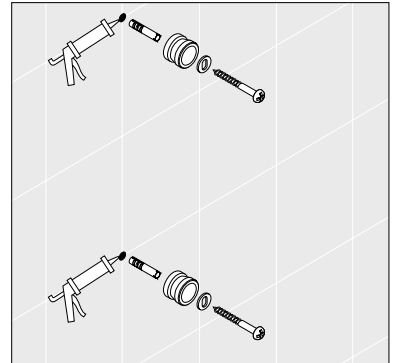

Place the wallbar over the mounting pieces (1).

Tighten the set screws with a 3 mm Allen wrench (2).

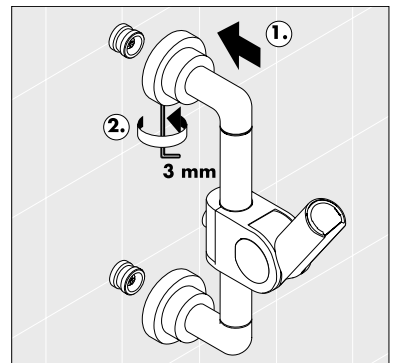

Axor Terrano / Carlton / Phoenix Wallbar Installation

Mark the positions of the screw holes, using the holes on the mounting pieces as a template. When positioning the support element on the wall, make sure that the notch is at the bottom.

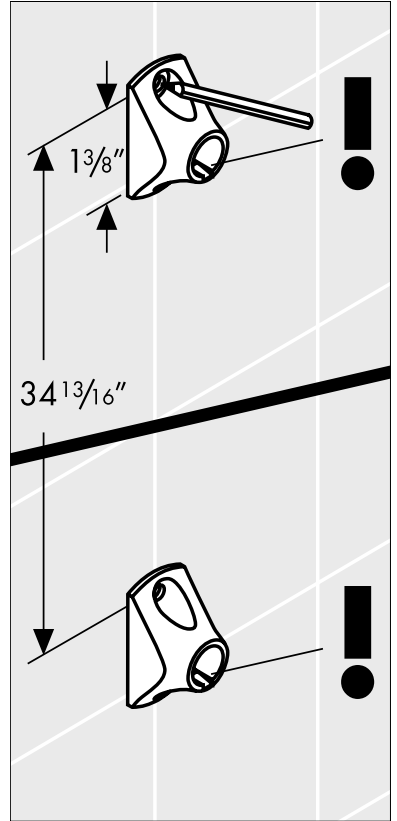

Put the support elements in a safe place. Drill the holes using a 6mm bit suitable for the wall surface.

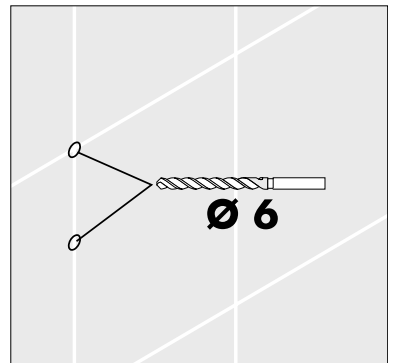

Install the anchors. Seal the wall around the anchors with waterproof sealant.

Screw the support elements to the wall with the screws.

Note: the gold deco-rings shown in the diagram are included only with Carlton model 27835090 (chrome with gold accents). They are not used with other models.

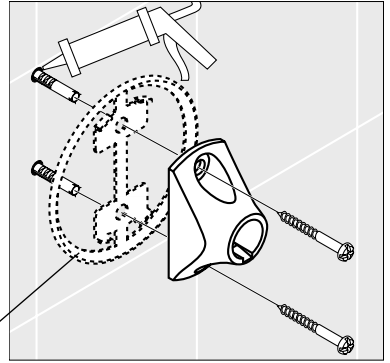

Deco ring

Position the wallbar over the support elements. Press the bar firmly into place.

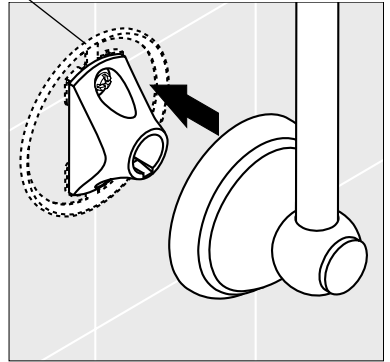

Wallbar removal:

Insert a small tool, such as an Allen wrench, through the hole in each escutcheon. Push upward against the retaining pin very firmly (1). Pull "out" on the end of the wallbar (2).

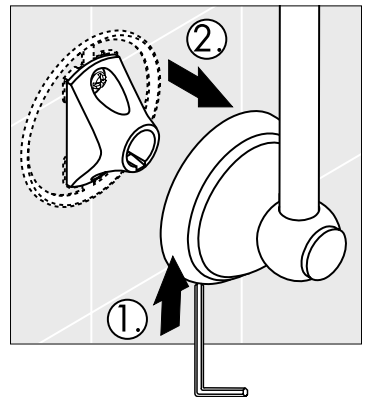

Slider Adjustment

Vertical adjustment

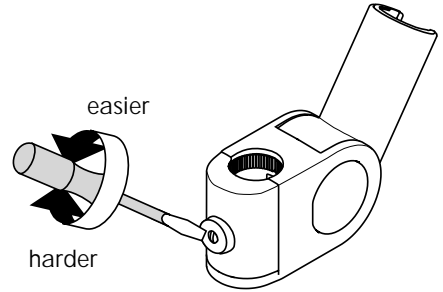
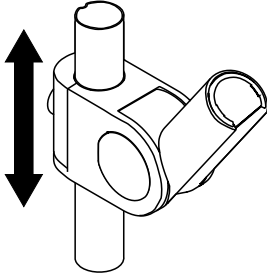

To adjust the resistance of the slider, use a screwdriver to turn the adjustment screw on the back of the slider. Turning the screw clockwise makes the slider harder to move, counter-clockwise makes it easier.

Angle adjustment

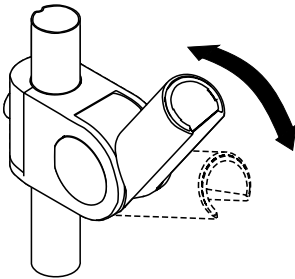

To change the resistance of the angle adjustment of the handshower holder, use a 3 mm Allen wrench to turn the adjustment screw on the bottom of the slider. Turning it clockwise makes it harder to move, counter-clockwise makes it easier.

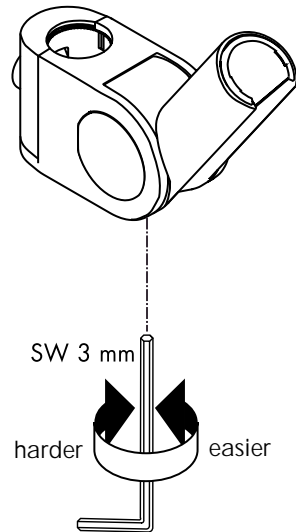

Install the handshower (not included)

Remove the protective cap from the handshower.

Place a black rubber hose washer in the shorter hose end connection. Screw this end to the wall supply (not included).

Place the screen washer in the longer hose end connection. Screw this end of the hose to the handshower.

Place the handshower and hose in the handshower holder on the slider.

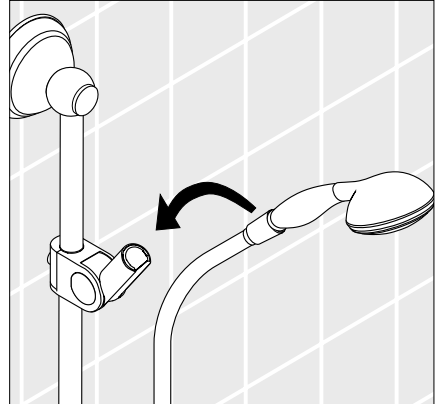
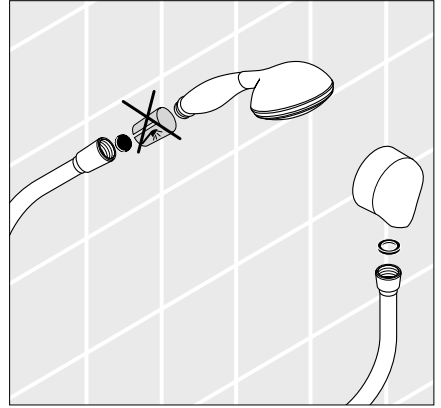

Replacement Parts 27831XXX

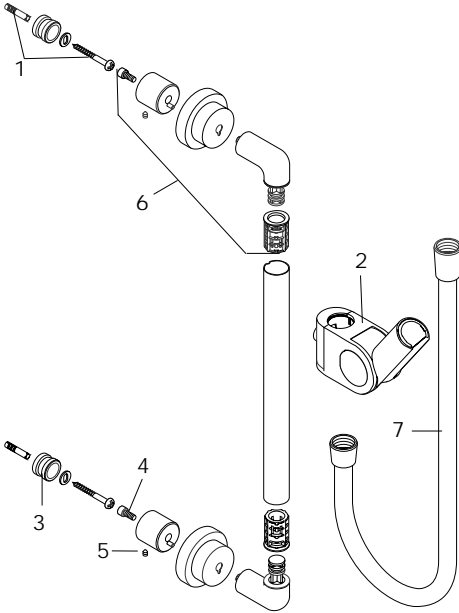

1	mounting set	40916000
2	slider	96505XXX
3	mounting piece	97597000
4	cylinder screw	97661000
5	set screw	97660000
6	wall support	97696XXX
7	hose	28276XXX

Replacement Parts 27834XXX

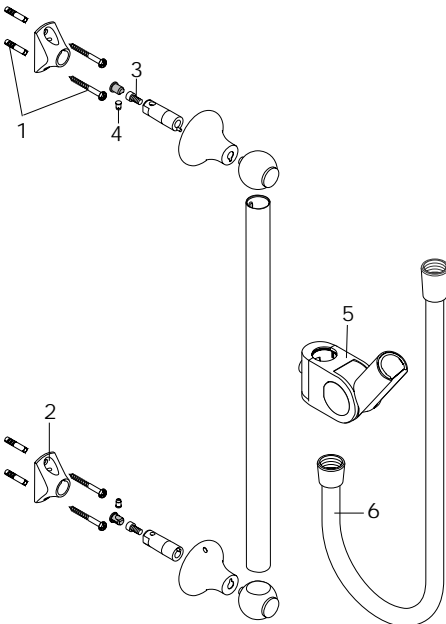

1	mounting set	96179000
2	support element	96341000
3	hexagon screw	97661000
4	pin	97546000
5	slider	96505XXX
6	hose	28276XXX

Replacement Parts 27835XXX

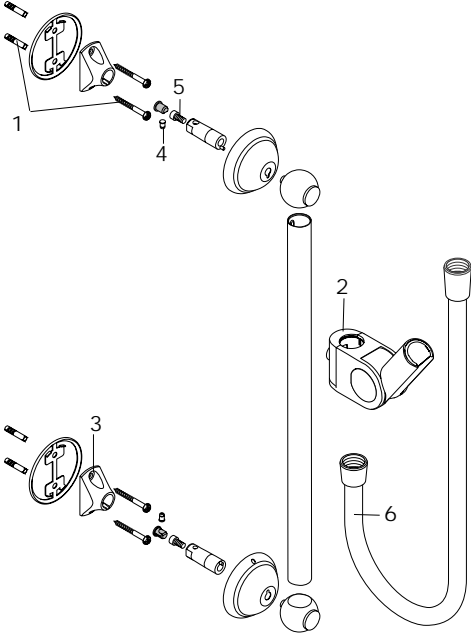

- | | | |
|---|-----------------|----------|
| 1 | mounting set | 96179000 |
| 2 | slider | 96505XXX |
| 3 | support element | 96341000 |
| 4 | pin | 97546000 |
| 5 | hexagon screw | 97661000 |
| 6 | hose | 28276XXX |

Cleaning Recommendation for Hansgrohe Products

Modern faucetry and shower products utilize a combination of materials to comply with the needs of the market with regard to design and functionality.

To avoid damage, it is necessary to use some caution when cleaning. Damage caused by improper treatment is not covered under the Hansgrohe warranty.

Cleaning Materials for Faucets and Showers

- To remove lime scale, use only products made specifically for that purpose. Always follow the manufacturer's instructions when using.
- Do not use cleaners that contain hydrochloric, formic, acetic, or phosphoric acids, as these will cause considerable damage to finishes and to plastic components.
- Never mix cleaning materials.
- Never use cleaners containing abrasives. Do not use abrasive cleaning cloths, pads, or sponges.

Cleaning Procedures

- Clean your faucets and shower products as and when required. Regular cleaning will prevent scale buildup and water spotting.
- Follow the label instructions. Do not allow any cleaner to remain on the product for longer than necessary.
- When using spray cleaners, spray first onto a sponge or cloth – do not spray directly onto the product.
- After cleaning, rinse thoroughly with clear water to remove any cleaner residue.

Important

- Soap and shampoo residue can also cause damage to the product. Rinse well with clean water after use.
- If the surface is already damaged, harsh cleaning materials will cause further damage.

Limited Lifetime Consumer Warranty

This product has been manufactured and tested to the highest quality standards by Hansgrohe, Inc. ("Hansgrohe"). This warranty is limited to Hansgrohe products which are purchased by a consumer in the United States after March 1, 1996 and installed in either the United States or Canada.

WHO IS COVERED BY THE WARRANTY

This warranty extends to the original consumer purchaser only.

WHAT IS COVERED BY THE WARRANTY

This warranty covers only your Hansgrohe manufactured product. Hansgrohe warrants this product against defects in material or workmanship as follows: Hansgrohe will repair at no charge for parts only or, at its option, replace any product or part of the product which proves defective because of improper workmanship and/or material, under normal installation, use, service and maintenance. If Hansgrohe is unable to provide a replacement and repair is not practical or cannot be timely made, Hansgrohe may elect to refund the purchase price in exchange for the return of the product.

LENGTH OF WARRANTY

Replacement or repaired parts of products will be covered for the term of this warranty as stated in the following two sentences. If you are a consumer who purchased the product for use primarily for personal, family, or household purposes, this warranty extends for as long as you own the product and the home in which the product is installed. If you purchased the product for use primarily for any other purpose, including, without limitation, a commercial purpose, this warranty extends only (i) for 1 year, with respect to Interaktiv and Retroaktiv products and (ii) for 5 years, with respect to AXOR, ShowerPower and Pharo products.

THIS WARRANTY DOES NOT COVER and HANSGROHE WILL NOT PAY FOR:

- A. Conditions, malfunctions or damage not resulting from defects in material or workmanship.
- B. Conditions, malfunctions or damage resulting from (1) improper installation, improper maintenance, misuse, abuse, negligence, accident or alteration, or (2) the use of abrasive or caustic cleaning agents or "no rinse" cleaning products, or the use of the product in any manner contrary to the product instructions.
- C. Labor or other expenses for the disconnection or return of the product for warranty service, or for installation or reinstallation of the product.
- D. Accessories or related products not manufactured by Hansgrohe.

TO OBTAIN WARRANTY SERVICE

Contact your Hansgrohe retailer, or write to Technical Service at:

Hansgrohe Inc.
1492 Bluegrass Lakes Parkway
Alpharetta GA 30004

Or, call Hansgrohe toll-free at (800) 334-0455.

In requesting warranty service, you will need to provide

- 1. The sales receipt or other evidence of the date and place of purchase.
- 2. A description of the problem.
- 3. Delivery of the product or the defective part, postage prepaid and carefully packed and insured, to Hansgrohe Inc. 1492 Bluegrass Lakes Parkway, Alpharetta, Georgia 30004, Attention: Technical Service, if required by Hansgrohe.

When warranty service is completed, any repaired or replacement product or part will be returned to you postage prepaid.

EXCLUSIONS AND LIMITATIONS

REPAIR OR REPLACEMENT (OR, IN LIMITED CIRCUMSTANCES, REFUND OF THE PURCHASE PRICE) AS PROVIDED UNDER THIS WARRANTY IS THE EXCLUSIVE REMEDY OF THE PURCHASER. HANSGROHE NEITHER ASSUMES NOR AUTHORIZES ANY PERSON TO CREATE FOR IT ANY OBLIGATION OR LIABILITY IN CONNECTION WITH THIS PRODUCT.

HANSGROHE SHALL NOT BE LIABLE TO PURCHASER OR ANY PERSON FOR ANY INCIDENTAL, SPECIAL, OR CONSEQUENTIAL DAMAGES, ARISING OUT OF BREACH OF THIS WARRANTY OR ANY IMPLIED WARRANTY (INCLUDING MERCHANTABILITY).

Some States do not allow the exclusion or limitation of incidental or consequential damages, so the above limitation or exclusion may not apply to you.

This warranty gives you specific legal rights and you may have other rights which vary from State to State.

You may be required by law to give us a reasonable opportunity to correct or cure any failure to comply before you can bring any action in court against us under the Magnuson-Moss Warranty Act.

PRODUCT INSTRUCTIONS AND QUESTIONS

Upon purchase or prior to installation, please carefully inspect your Hansgrohe product for any damage or visible defect. Prior to installing, always carefully study the enclosed instructions on the proper installation and the care and maintenance of the product. If you have questions at any time about the use, installation, or performance of your Hansgrohe product, or this warranty, please call or write to us at the toll-free number and address printed above.

hansgrohe

Hansgrohe, Inc. • 1490 Bluegrass Lakes Parkway • Alpharetta, GA 30004
Tel. 770 360-9880 • Fax 770 360 9887

www.hansgrohe-USA.com