



GOLDEN

Elegant lighting for everyday living

PARTS & ASSEMBLY SHEET





Fixture Name: **Aro 9174-WSC GB**

This fixture assembled PO: _____ Date: _____

Notice: Please review the parts listing and check for all parts before assembling the fixture. If any parts are missing or damaged, please note on this sheet and contact the place of purchase to arrange for replacement parts.

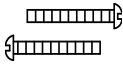
PARTS LIST

Company Name: _____ Co. Account #: _____
to be filled out by retailer

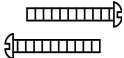
Circular mounting strap	1ea  Φ102mm*1.5mm	Mounting Screws	 2ea 8*38mm	Hex Nut	 2ea Φ9mm*4mm
Deco or Ball Nut	2ea  Φ12mm*10mm	Wire connectors	 3ea	Green screw	 1ea Φ9mm*10mm
Mounting Screws	 2ea Φ8*25mm				

Part Needed	_____	Quantity	_____
Part Needed	_____	Quantity	_____
Reason why	(missing, scratched, broken glass, bent, bad finish)		
Comments	_____		

FIXTURE ASSEMBLY INSTRUCTIONS

Read and review installation instruction sheet before assembling the fixture.

1. Place the Shade (F) into the Fixture frame (D). There is a lip at the bottom of the Fixture frame (D) for the shade to rest on.

(DO NOT EXCEED MAXIMUM WATTAGE RATING!)

NOTE: INSTALL THE GLASS ASSEMBLY AFTER THE FIXTURE IS HUNG.

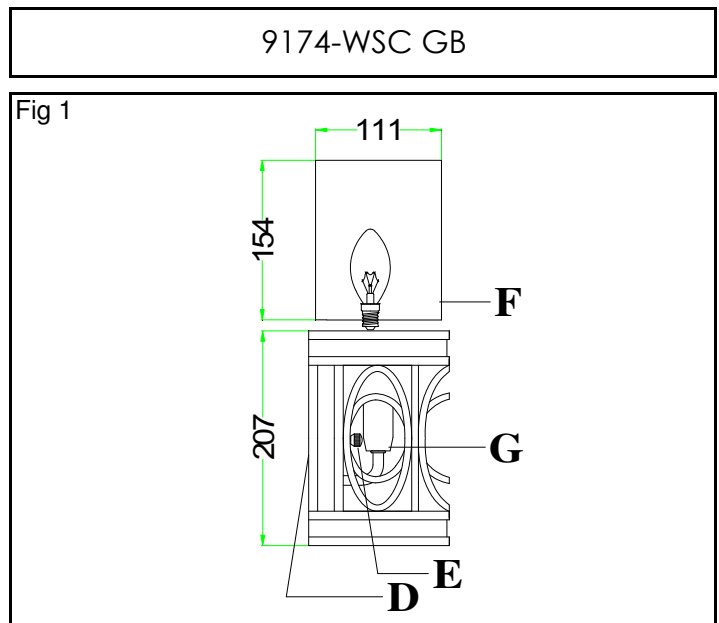

For Customer Service, contact the place of purchase to arrange for replacement parts.

WARNING ! SHUT OFF POWER AT FUSE OR CIRCUIT BREAKER.

HANGING THE FIXTURE (Fig. 1)

1. Carefully remove the new fixture from the carton and the yellow bag that holes all your parts. Check that all parts are included as shown in the illustration and parts list.
2. Shut off the power at the circuit breaker and remove the old fixture from wall, including the old mounting strap.
3. The Mounting Strap (A) contains several pairs of threaded holes, find the pair of holes that match the holes spacing in your fixture Back Plate (D) and thread the two Mounting Screws (C) half way into the Moutning Strap (A).
4. Place the Mounting Strap (A) over the Junction Box so the Mounting Screws (C) are vertical or horizontal, as required by fixture type .
5. Attach the Mounting Strap (A) to the Junction Box using the two mounting screws (B). Tighten the screws (B) securely with screws driver.

CONNECTING THE WIRES (Fig. 2)

6. Attach the power supply wires to the fixture lead wires by connecting BLACK to BLACK (or SMOOTH) and WHITE to WHITE (or RIBBED).
 7. Attach the GROUND wire (GREEN or COPPER) from the Junction Box and the fixture Ground wire to the green Ground Screw on the Mounting Bracket (B) or connect both wires together using the correct size of wires connectors.
- NOTE :** Twist the wires together in the same direction you twist the wire connector onto the wires.
8. Tuck these wire connections neatly into the Junction Box.

FINISHING THE INSTALLATION (Fig. 3)

9. After tucking these wire connections neatly into the Junction Box and place the fixture Back plate (D) over the two Mounting Screws (C) and secure the Back Plate (D) against the wall by threading two Deco nuts (E) over the two Mounting Screws (C) until tight as shown on fig.1.

YOUR INSTALLATION IS NOW COMPLETE.

RETURN POWER TO THE JUNCTION BOX AND TEST THE FIXTURE

Fig. 1

JUNCTION BOX

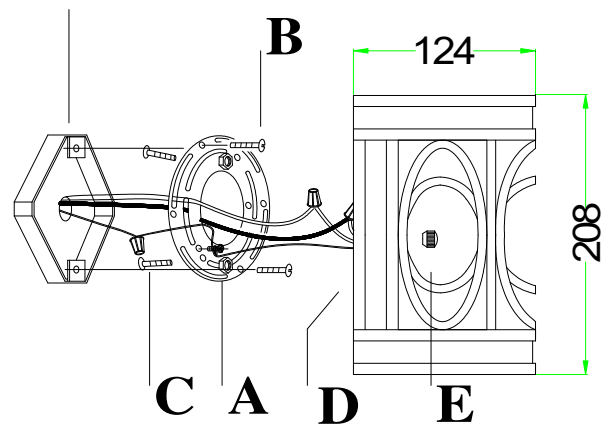

Fig. 2

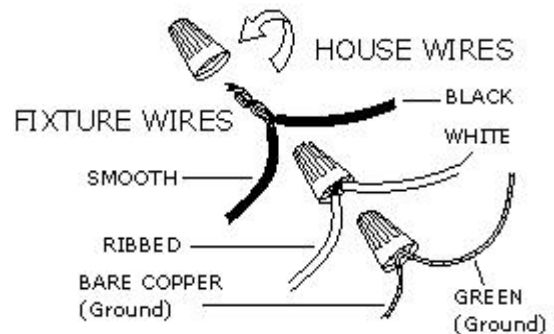

Fig. 3

