



COMMERCIAL PLASTIC SEATS

MODEL 255

Seats shall be No. 255 as manufactured by Church Seats. Seats shall be commercial weight and injection molded of solid plastic. Seats shall be open front less cover for elongated bowl and feature large molded-in bumpers. External check hinges to feature 300 Series stainless steel posts that stop seat 11 degrees beyond vertical. Uses 300 Series stainless steel hardware. Color to be white.

- ELONGATED SEAT
OPEN FRONT LESS COVER
- SOLID PLASTIC
- EXTERNAL 300 SERIES
STAINLESS STEEL CHECK HINGE

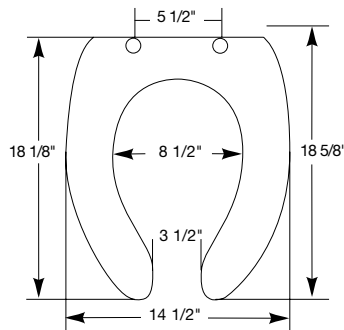
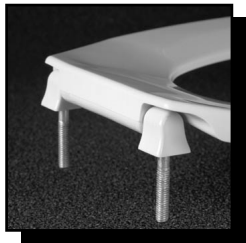

Ring thickness is 13/16"
Ring thickness including the bumper is 1"
Height of the seat with cover is 1-1/2"

