

EDGE STAR[®]

Portable Ice Maker

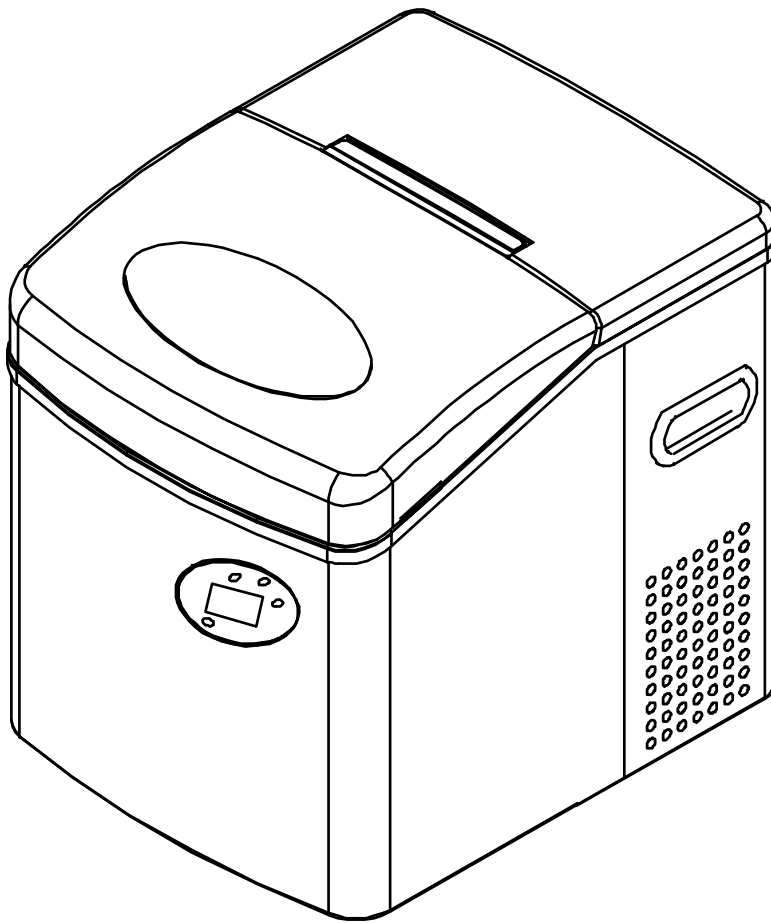

IP250SS

Owner's Manual

For more information on other great EdgeStar products on the web, go to <http://www.edgestar.com>

Important Safety Information

Improper handling can cause serious damage to the EdgeStar ice maker and/or injury to the user. This ice maker is designed for domestic indoor use only. Do not use the unit for industrial or commercial use. Any other use may invalidate the warranty. Please review the ratings label located on the rear panel of the unit for electrical and other technical data related to this unit. The unit must be used in a properly grounded wall outlet. Please read and follow the safety information listed below to reduce the risk of fire, electric shock or injury.



Electrical Safety

- Do not exceed the power outlet ratings.
- It is recommended that the ice maker be connected on its own circuit.
- A standard electrical supply (115 V, 60Hz), that is properly grounded in accordance with the National Electrical Code and local codes and ordinances is required.
- Use outlets that cannot be turned off by a switch or pull chain.
- Always turn the unit off and unplug it from the outlet when cleaning.
- Unplug the unit if it is not going to be used for an extended period of time.
- Do not operate the unit with a power plug that is missing the ground plug, a damaged cord or a loose socket.
- Be sure the ice maker is properly grounded.
- Never plug or unplug the unit with wet hands.
- Do not bypass, cut or remove the grounding plug.
- Do not use extension cords or power strips with this unit. You may need to contact your electrician if it is necessary to use a longer cord or if you do not have a grounded outlet. Do not modify the power cord's length or share the outlet with other appliances. If you must use an extension cord, use No. 14AWG minimum size and rated no less than 1875 watts.
- Do not start or stop the unit by switching the circuit's power on and off.
- If the power cord is damaged, it must be replaced by the manufacturer or a qualified technician.
- Never repair the unit while it is plugged in.
- Immediately unplug the unit if it makes strange sounds, emits an odor or smoke comes out of it, and contact customer service.
- Do not remove any part of the casing unless instructed by an authorized technician.
- You should never attempt to repair the unit yourself.
- Contact EdgeStar Support if the unit needs repair service.
- Do not tip the unit over while it has water in the reservoir.



General Safety

- Use at least two people to move and install the ice maker to prevent back and other types of injuries.
- Install the ice maker in a well ventilated area where the ambient temperature is above 50°F and below 90°F.
- This unit is designed to be installed indoors, and protected from rain, sleet, snow, etc. Do not use your ice maker outdoors. Place the ice maker away from direct sunlight and make sure that there is at least 4 inches of space between the back of your unit and wall. Keep a minimum distance of 4 inches on each side of your unit free.
- This unit is not intended to be used by children and should be supervised to ensure that they do not play with this product.
- Never allow children to crawl inside the ice maker.
- Do not use this appliance near flammable gas or combustibles, such as gasoline, benzene, thinner, etc.
- Do not place the unit near heat sources such as ovens and grills.
- Only use in an upright position on a flat, level surface and provide proper ventilation.
- Discard the first batch of cubes produced by the ice maker.
- If the unit has not been used for an extended period, thoroughly clean it before using it.
- Do not leave any cleaning solutions in or on the unit
- Do not use solvent-based cleaning agents or abrasive solutions on the interior as they may transmit taste to the ice cubes and damage the interior.
- Do not clean the unit with flammable fluids. The fumes can create a fire hazard or cause an explosion.
- Other than water do not use other types of liquid to make ice.
- This appliance is not intended for use by persons, including children, with reduced physical, sensory or mental capabilities, unless they have been given supervision or instruction concerning the use of the appliance by the person(s) responsible for their safety.

Table of Contents

IMPORTANT SAFETY INFORMATION	1
INTRODUCTION	1
PARTS IDENTIFICATION	2
INSIDE VIEW	2
OUTER VIEW.....	2
BEFORE YOU BEGIN: PREPARING THE ICE MAKER FOR USE	3
UNPACKING THE ICE MAKER	3
CLEANING THE ICE MAKER	3
INSTALLATION REQUIREMENTS	3
<i>Clearance and Environment Requirements</i>	3
<i>Water Requirements</i>	3
<i>Electrical Requirements</i>	3
OPERATION	4
USING YOUR ICE MAKER	4
USING THE CONTROL PANEL	5
HOW THE PORTABLE ICE MAKER PRODUCES ICE	8
DRAINING THE UNIT	8
NORMAL SOUNDS	8
CLEANING AND MAINTENANCE	9
TROUBLESHOOTING	10
SPECIFICATIONS	11
LIMITED WARRANTY	12

This owner’s manual is provided for reference use only. Specifications may change without prior notice. Refer to the product label on the back of your ice maker for the latest technical information.

Introduction

Thank you for purchasing this EdgeStar ice maker. We are glad you chose us. We believe that your purchase of this product opens a relationship between you and EdgeStar. We will provide the customer support needed to nurture that relationship.

This manual contains important information regarding the proper installation, use and maintenance of your ice maker. Following this manual will ensure that your product will work at its peak performance and efficiency.

Please save the original product packaging in case you need to safely transport your portable ice maker.

For Your Records:

Please write down the model number and serial number below for future reference. Both numbers are located on the ratings label on the back of your unit and are needed to obtain warranty service. You may also want to staple your receipt to this manual as it is the proof of your purchase, and is also needed for service under your warranty.

Model Number: _____

Serial Number: _____

Date of Purchase: _____

To better serve you, please do the following before contacting customer service:

- If you received a damaged product, immediately contact the dealer that sold you the product.
- Read and follow this instruction manual carefully to help you install, use and maintain your ice maker.
- Read the troubleshooting section of this manual as it will help you diagnose and solve common issues.
- Visit us on the web at <http://www.edgestar.com> to register your product, download product manuals, and access additional troubleshooting resources and up-to-date information.
- If you need warranty service, our friendly customer service representatives are available via email at service@edgestar.com or by telephone at **1 (866) 319-5473**.

Parts Identification

Outer View

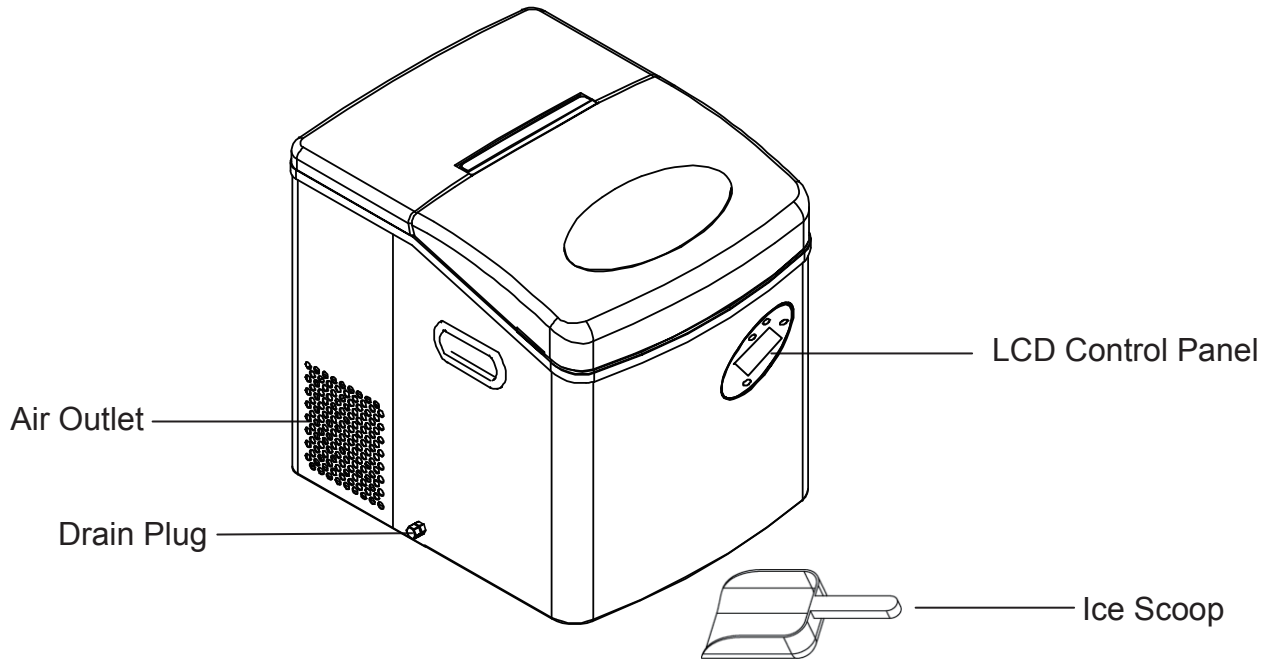

Inside View

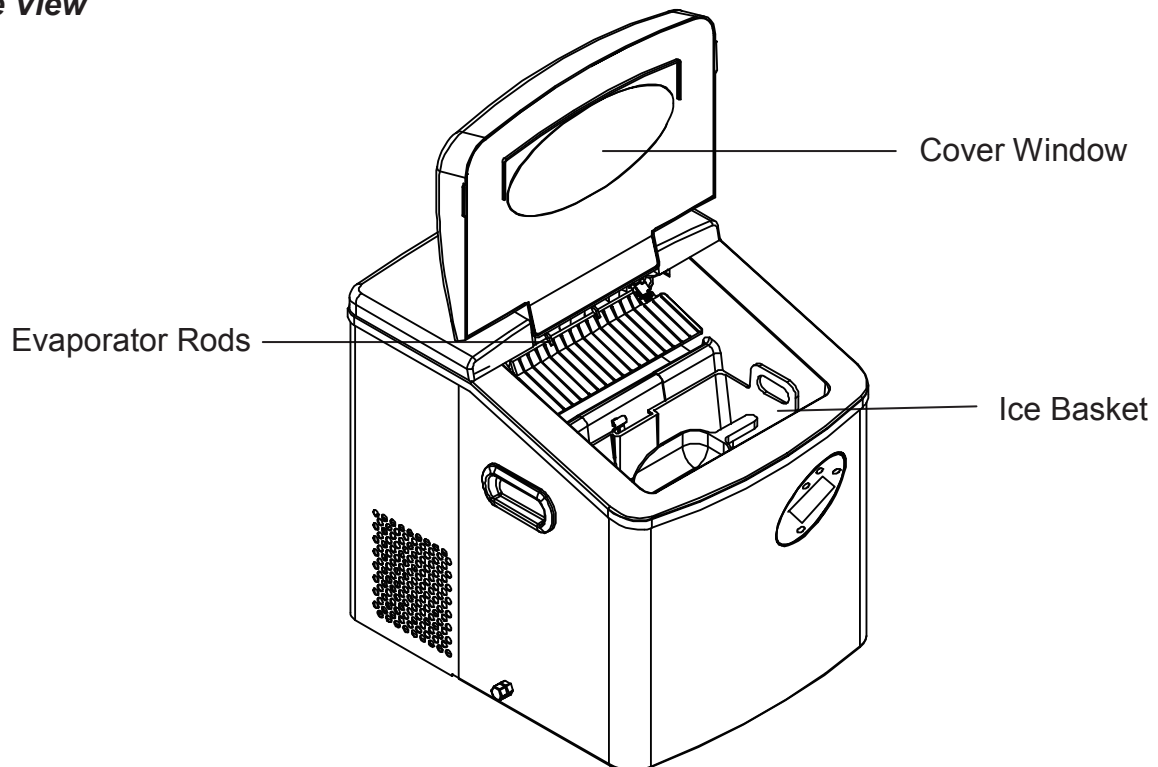

Before you Begin: Preparing the Ice Maker for Use

Before you plug the ice maker in to a power supply, be sure to let it stand upright for at least 24 hours to allow the compressor's oils to settle.



IMPORTANT: Do not remove any safety, warning, or product information labels from your ice maker.

Unpacking the Ice Maker

Carefully remove the packaging materials. Remove any shipping tape and glue from your ice maker before using. Do not use sharp instruments, rubbing alcohol, flammable fluids, or abrasive cleaners to remove tape or glue. These products can damage the surface of your ice maker. Check to make sure the ice basket and ice scoop are included. If any parts are missing, please contact our customer service. Put the ice maker on a level and flat surface away from direct sunlight and other sources of heat such as a stove, furnace, radiator, etc. The appliance must be positioned so that the power plug is accessible.

Cleaning the Ice Maker

Follow the Cleaning and Maintenance section to clean the ice maker.

Installation Requirements

The ice maker has been designed for freestanding installation which will allow you to install the unit in almost any place you desire provided you level the unit and follow the instructions for clearance, water and electrical requirements.

Note: If the room temperature is lower than 60°F, it is best to select the small size setting; otherwise, the ice cubes may stick together.

Clearance and Environment Requirements

- Choose a well ventilated area with temperatures above 50°F and below 90°F. Operation outside these temperatures may result in lowered production or may cause other adverse effects.
- This unit **MUST** be installed in an area protected from the elements, e.g., wind, rain, water spray or drips. The ice maker should not be located next to ovens, grills or other high heat sources.
- The unit should be located on a firm and level surface that is able to support the ice maker's total weight with water.
- There must be at least 4 inches of space around the back and sides of the unit for proper air circulation.

Water Requirements

- Only use potable water or water suitable for drinking.
- The temperature of the water should be between 51°F and 90°F.
- Change the water in the water reservoir every 24 hours to ensure a reasonable hygiene level.

Note: The add water light uses an electronic sensor that may not detect purified, filtered, reverse osmosis, or distilled water. You may need to add a pinch of salt to the water to increase the mineral content.

Electrical Requirements

Read all safety precautions listed at the beginning of this manual. It is recommended that a separate circuit serving only your ice maker be provided. Use receptacles that cannot be turned off by a switch or pull chain.



WARNING! Do not, under any circumstances, cut or remove the third (ground) prong from the power cord.

The ice maker is equipped with a power supply cord having a 3-prong grounding plug. To minimize possible shock hazard, the cord must be plugged into a mating 3-pronged and grounding-type wall receptacle providing 110-120V, 60Hz, grounded in accordance with the National Electrical Code and local codes and ordinances. If a mating wall receptacle is not available, it is the personal responsibility of the customer to have a properly grounded, 3-prong wall receptacle installed by a certified electrician.

Operation

Using Your Ice Maker

Before using your ice maker, it is strongly recommended to clean it thoroughly. Read and follow the Cleaning and Maintenance section of the manual before proceeding.

Follow the steps below to start using your ice maker.

1. Open the top cover and remove any packaging tape that may be holding down the ice case, ice shovel, ice basket and ice scoop. Remove the ice scoop.
2. Remove the ice basket and clean it.

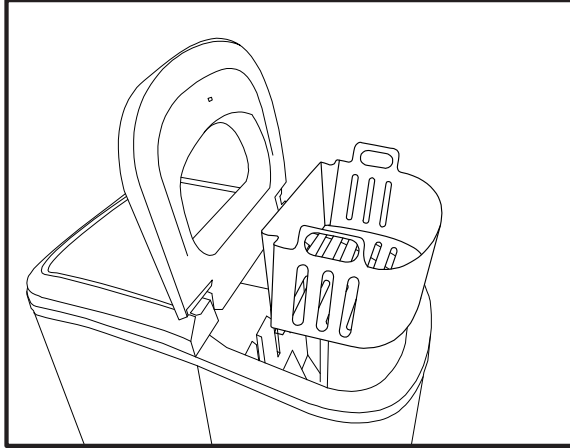

3. Clean the water reservoir.
4. Pour water into the water reservoir. Keep the water level below the “MAX” water mark.

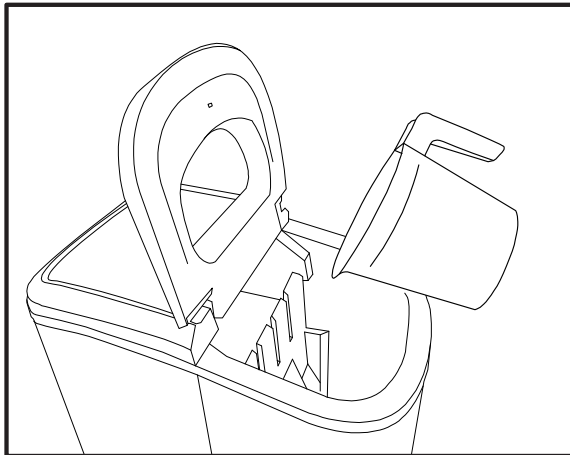

5. Insert the ice basket into the water reservoir.
6. Close the lid.
7. Plug the ice maker’s power plug in to a grounded outlet.
8. Press the **On/Off** button on the Control Panel.
9. Press the **Select** button on the Control Panel to choose between small, medium and large size cubes. If the room temperature is lower than 60°F, it is best to select the small size setting; otherwise, the ice cubes may stick together. The ice making cycle may take up to 13 minutes for a single batch of ice.

Notes: If the water pump is unable to detect or pump water, the unit will stop automatically, and the “Add Water” indicator will display. Add water to the unit and restart the unit by pressing the **On/Off** button twice. The ice maker will continue making ice until the ice basket is full. When the ice basket is full, the “Ice Full” indicator will light up.



IMPORTANT: Discard the first batch of ice produced by the portable ice maker.

CAUTION: Direct sunlight may cause the ice full infrared sensor to malfunction. If the unit continues to produce ice even though the basket is full, you may need to move the unit away from the sunlight.

Using the Control Panel



IMPORTANT: Do not power on the unit without any water.

Control Panel & LCD Display

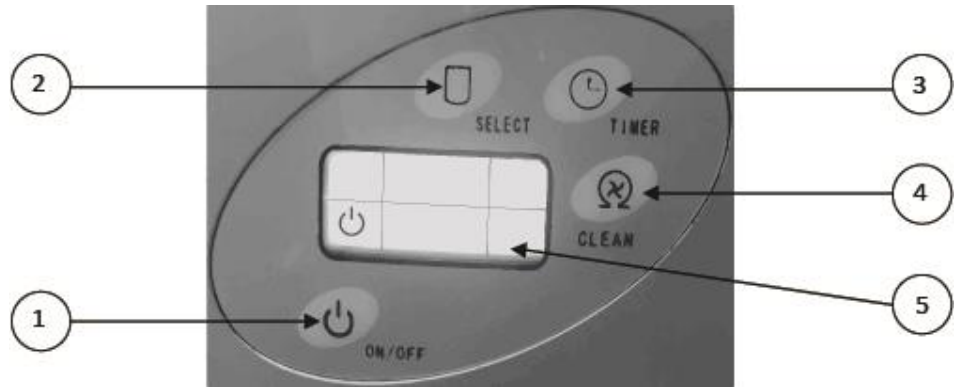

1. ON/OFF button: powers the unit on or off.
2. SELECT button: press to cycle through desired ice cube sizes (small, medium or large).
3. TIMER button: press to set the unit's timer (refer to Timer Function section).
4. CLEAN button: starts the self-cleaning function (refer to Self-clean Function section).
5. LCD display window: displays the unit's settings and indicators.

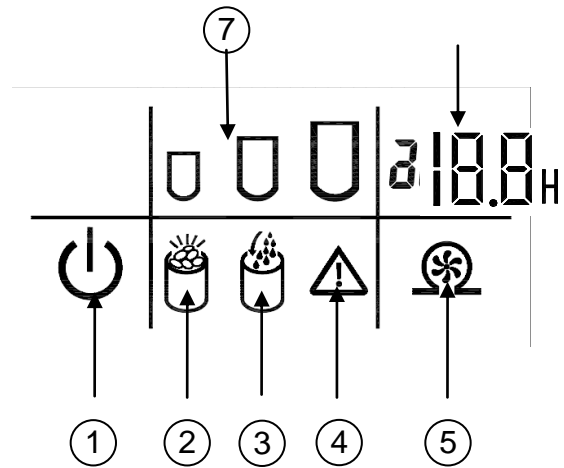

LCD DISPLAY SYMBOLS



#	Indicator	Function
1	POWER INDICATOR	Displays whether the unit is powered on or off.
2	ICE FULL	The ice full symbol will turn on if the ice basket is full. The unit will not resume ice production until room is made in the ice basket.
3	WATER INDICATOR	The water indicator symbol will flash when there is no water in the unit's reservoir. This light will also remain on when the unit is in self-cleaning mode.
4	WARNING LIGHT	See the Troubleshooting section.
5	SELF-CLEAN	Indicates that the ice maker is in self-clean mode (see the Self-clean Function section). This light will also remain on when the unit is in self-cleaning mode.
6	TIMER	Displays remaining time that the unit will stay on if already on, or if unit is off, how long before it turns on.
7	ICE SIZE INDICATOR	Displays the size of the ice being produced (small, medium or large).

Self-clean Function

1. Take out the ice basket.
2. Add a 10:1 mixture of water to vinegar.
3. Plug in the unit, and hold the CLEAN button for six (6) seconds. The self-cleaning process will last about 5-6 minutes; after, the unit will automatically

power off. During this process, symbols  and  will display in the LCD display window.

4. After the self-clean program is complete, drain out the water/vinegar mixture by unplugging the drain cap on the side. Then close the drain cap.
5. Unplug the unit and add fresh water into reservoir up to the "Max" water level mark.
6. Plug the unit back in, and hold the CLEAN button for six (6) seconds again.
7. After the self-clean program is complete (within approximately 5-6 minutes), drain out the water by unplugging the drain cap on the side.
8. Dry the interior and exterior with a soft and clean cloth.
9. Tighten the drain cap.

Suggestion: When you first use the unit or have been not in use for a long time, we suggest that you clean the unit according the above program first before using.

Timer Function

How to set

When the unit is turned off, you can set its timer to start ice production sometime in the future.

- 1). Press the **TIMER** button on the control panel.  will flash on the LCD display at the top right.
- 2). Press the **SELECT** button to change the time delay to your desired number of hours in the future. The timer ranges from 0.5 hours to 18 hours, changing in 0.5 hour increments.
- 3). After you have selected the time delay, do not press any buttons for three (3) seconds. The timer display will then show the time remaining set time until the unit will start ice production automatically according to your settings. Ice production will begin once the timer reaches zero (0).

When the unit is turned on, you can set its timer to stop ice production after a set duration.

- 1). Press the **TIMER** button on the control panel.  will flash on the LCD display at the top right.
- 2). Press the **SELECT** button to change the time delay to your desired number of hours in the future. The timer ranges from 0.5 hours to 18 hours, moving in 0.5 hour increments.
- 3). After you have selected the time delay, do not press any buttons for three (3) seconds. The timer display will then show the time remaining set time until the unit will stop ice production. Ice production will cease once the timer reaches zero (0).

How to cancel

To cancel the timer setting, press the **TIMER** button twice.

How the Portable Ice Maker Produces Ice

After the unit is powered on, the ice maker begins with rotating the ice case into a horizontal water fill position under the evaporator. The water pump is engaged and fills the ice case with water. Water overflows for a few seconds before the compressor turns on. The compressor then pumps refrigerant and the fan will turn on automatically after the condenser heats up. The unit produces bullet shaped ice around the stainless steel evaporator. When the batch of ice has been fully formed, the ice maker stops the freeze cycle and begins the harvest cycle. A valve opens diverting hot refrigerant gas into the evaporator. The gas heats the evaporator causing the ice cube bullets to slide off the evaporator. The ice shovel will automatically push the newly formed ice into the ice basket, and will move the ice case back into the water fill position for the next batch of ice. The ice maker will produce ice until ice reaches the ice full sensor, or until the unit is out of water. The ice bin compartment is insulated, but not refrigerated and the ice in the bin will slowly melt and the water will be reused. Once enough of the ice has melted, the ice maker will automatically start making more ice.



WARNING! Do not tip the unit over while there is water in the reservoir.

Draining the unit

Follow the steps below to drain the unit.

1. Carefully move the unit towards a sink or other suitable location for draining.
2. Remove the rubber drain plug from the bottom of the water reservoir to drain all the water.
3. Firmly install the rubber drain plug into the drain port.

Normal Sounds

Your new ice maker may make sounds that are not familiar to you. Most of the new sounds are normal. Hard surfaces like the floor, walls can make the sounds seem louder than they actually are. The following describes the kinds of sounds that might be new to you and what may be making them.

- The ice case motor will make a whirling noise when the ice case and shovel are moving.
- Rattling noises may be produced from the flow of the refrigerant.
- The compressor may make a pulsating or high-pitched sound.
- The compressor may also produce a low tone humming sound.
- Water that is being pumped into the ice case will make trickling, dripping or splashing sounds.
- As each cycle ends, you may hear a gurgling sound due to the refrigerant flowing.
- You may hear fan noise and air being forced over the condenser by the condenser fan.
- During the harvest cycle, you may hear the sound of ice cubes falling into the ice basket.
- If the ice maker is run without water, the water pump will make a screeching noise. **Note: Do not run the unit without water!**



The ice maker must be thoroughly cleaned if it has been left unused for a long time. Follow carefully any instructions provided for cleaning or use of sanitizing solution. Do not leave any solution inside the ice maker after cleaning.

CLEANING AND MAINTENANCE

Periodic cleaning and proper maintenance will ensure efficiency, top performance and long life.

Never use a solvent-based cleaning agent. These cleaners may transmit taste to the ice cubes, or damage and discolor the interior. You should unplug the unit before cleaning the exterior and interior.

Before using your ice maker, you are strongly recommended to clean it thoroughly. You can do so utilizing the unit's self-clean function or manually, as described below.

1. Take out the ice basket.
2. Clean the interior with a diluted cleaning solution, warm water and a soft cloth. (DO NOT use any caustic or abrasive solutions or clean your ice maker with flammable fluids.)
3. The outside of the ice maker should be cleaned regularly with a mild detergent and warm water.
4. Dry the interior and exterior with a soft cloth.

It is advised to periodically clean the machine with a nickel-safe ice maker cleaner every 6 months to maintain cleanliness.

If the ice has a strange taste

If the ice has an unappealing taste, or the unit develops a musty odor, try running a few cycles of the ice maker with a mild white vinegar solution or lemon juice. Then empty out all the vinegar or lemon juice solution and run a few cycles with plain water to eliminate all traces of the vinegar or lemon juice.

If you find the bad taste remains after this procedure, use a solution of two (2) tablespoons of baking soda to a full water reservoir of water left in the unit overnight to absorb any remaining odors/tastes. Drain the solution, rinse the water reservoir and dry the interior.



IMPORTANT: DO NOT turn the ice maker upside-down while you are cleaning or drying the unit. The oil inside the compression unit will shift, which could result in the ice maker breaking or becoming inoperable.

Routine maintenance

1. Take out the ice basket.
2. Add a mild cleaning solution mixture to the water reservoir. Use a 10:1 ratio of water to either white vinegar or lemon juice.
3. Run the ice maker to make a couple of batches of ice (at least two (2)). Discard the ice.
4. Drain the cleaning solution from the water reservoir.
5. Remove the water line from above the evaporator and clean and rinse it out.
6. Add fresh water to the water reservoir up to the water level mark.
7. Run the ice maker to make a few batches of ice. Discard the ice.
8. Drain the water.
9. Add fresh water to the water reservoir to make ice, or dry the interior and exterior with a clean, soft cloth to store the machine.
10. The ice scoop should be washed regularly. Wash it just like any other utensil.





If the ice maker will not be used for an extended period of time, you should unplug the unit from power, drain the water from the reservoir and dry the interior with a clean soft cloth.

- *Do not touch the power plug when your hands are wet.*
- *Do not try to remove the evaporator from the unit.*
- *Never unplug the unit by pulling on the plug.*

TROUBLESHOOTING

Before Calling for Service

If the unit appears to be malfunctioning, the issue could be solved by following the suggestions in the “Solution” column.

Issue	Possible Cause	Solution
No Power	The ice maker is unplugged	Plug the ice maker in
	The ice maker power switch is OFF	Press the power button. The Power Indicator light should be on
	Power outlet does not work	Try a different power outlet. If the unit works on a different circuit, you may need to contact a certified electrician to resolve the power issue
	Insufficient power	Connect the ice maker on a circuit that is able to provide enough power. Check the product label for power requirements
	Hardware malfunction	Contact EdgeStar support
Water is leaking out the unit	The bottom drain plug is not attached	Make sure the drain plug is firmly attached. If the drain plug has been lost, you may need to contact EdgeStar to purchase a replacement plug
	An internal hose may have been dislodged or disconnected	Contact EdgeStar support
Noise during operation	The unit may not be level	Make sure the unit is level and not at an incline
	Certain sounds are normal	See the “Normal Sounds” section of this owner’s manual
	A loud knocking or metallic pinging noise may be caused by a damaged compressor	Contact EdgeStar support
Unit goes through the ice making process, but no ice is produced, or ice cubes are very thin and small	The room temperature or water may be too hot. The unit is designed to work in a room that is above 50°F and below 90°F	If the unit is run in a room that is particularly warm such as a sunroom or laundry room, please move the unit to a cooler room and try again
	The fan may not be turning on to cool down the condenser coils	Contact EdgeStar support
The “Add Water” light is on even though the unit is full of water	The type of water may not have enough impurities, i.e., distilled, reverse osmosis [RO], purified, etc.	Add a pinch of salt to the water. This will add minerals to the water which will allow the unit to detect the water
	The water filter may be clogged	Use a brush with plastic bristles to clean the filter at the bottom of the water reservoir
The unit has a strange smell or the ice being produced has an unappealing taste	The unit may need to be cleaned	Read the Cleaning and Maintenance section of this manual
 symbol is on in LCD	Ice shovel cannot rotate	Check if any ice cubes are blocking the ice shovel, and clear them. Otherwise, consult a certified technician to check the motor and microswitch
 symbol flashes for 20 seconds on LCD	The ice full sensor on the edge of the reservoir may not be working properly	Contact EdgeStar support
 symbol is on LCD	There is too much ice in the basket	Remove ice from the basket
 symbol is flashing	There is not enough water in the reservoir	Stop the ice maker, fill it with water, then restart it

Specifications

Description of product	Portable Ice Maker
Model	IP250SS
Voltage/Frequency	AC 115V~60Hz
Ice-Making / Ice-Harvest rated current	2.1A / 3.2A
Color	Stainless Steel
Ice Storage capacity	2.6 lbs
Ice-making capability	48 lbs. per day*
Refrigerant	R134a, 3.35 oz. / 95g
Dimensions (Width x Depth x Height)	17 1/8" W x 17" D x 15" H
Weight	36.8 lbs

Note: Technical data and performance information provided for reference only.

Specifications are subject to change. Check the rating label on the ice maker for the most accurate information.

* The actual quantity of ice produced in a 24hour period will vary with room and water conditions.

Notes on ice storage

The ice maker will automatically shut off when the ice bin is full. The ice bin compartment is insulated, but not refrigerated and the ice in the bin will slowly melt and the water will be reused. Once enough of the ice has melted, the ice maker will automatically start making more ice.

Limited Warranty

One (1) Year Parts & Ninety (90) Days Labor

This product is warranted by EdgeStar to be free from defective workmanship and materials, subject to any conditions set forth as follows:

WHAT IS COVERED:

LABOR: For a period of NINETY (90) DAYS from the date of original purchase, labor will be performed free of charge at an authorized EdgeStar repair facility. At its option, EdgeStar will repair the product with new or remanufactured parts, or exchange the defective product with a new, refurbished, or remanufactured product. If a product is replaced, it will carry the remaining warranty of the original product. After the ninety (90) day period, EdgeStar will no longer be responsible for labor charges incurred. All defective products and parts covered by this warranty will be repaired or replaced on a mail-in basis to an EdgeStar authorized repair facility.

PARTS: For a period of ONE (1) YEAR from the date of original purchase, EdgeStar will supply new, rebuilt, or refurbished parts free of charge. EdgeStar may request a defective part be returned in exchange for the replacement part. All replacement parts or products will be new, remanufactured, or refurbished. All products and parts replaced by EdgeStar under warranty service become the property of EdgeStar.

This warranty applies to the original purchaser only, and only covers defects in workmanship experienced during operation of the product under normal service, maintenance, and usage conditions. This warranty applies to the purchase and use of this product in residential settings within the United States of America.

WHAT IS NOT COVERED:

The following limitations apply to the coverage of this warranty. This warranty does not cover:

- Labor charges for installation, setup or training to use the product.
- Shipping damage, and any damage caused by improper packaging for shipment to an authorized service center, and any damaged caused by improper voltage or any other misuse, including abnormal service, handling, or usage.
- Cosmetic damage such as scratches and dents.
- Normal wear and tear on parts or replacement of parts designed to be replaced, e.g. filters, cartridges, batteries.
- Service trips to deliver, pick-up, or repair, install the product, or to instruct in proper usage of the product.
- Damages or operating problems resulting from misuse, abuse, operation outside environmental specifications, uses contrary to instructions provided in the owner's manual, accidents, acts of God, vermin, fire, flood, improper installation, unauthorized service, maintenance negligence, unauthorized installation or modification, or commercial use.
- Labor charges incurred 91 days or more after the date of original purchase.
- The use of EdgeStar products in commercial settings.
- Optional accessories, attachments, and appearance items.
- Products that have been modified to perform outside of specifications without the prior written permission of EdgeStar.
- Products lost in shipment, or theft.
- Products sold AS IS or from an unauthorized reseller.
- Products that have had their serial numbers removed or defaced. Products with serial numbers that have been invalidated.

OBTAINING WARRANTY SERVICE:

If you believe your product is defective, contact EdgeStar Customer Support for troubleshooting assistance and warranty service at 1-866-319-5473. Please have your serial number and proof of purchase available. Once an EdgeStar authorized representative has confirmed that your product is defective and eligible for warranty service, the product must be returned to an EdgeStar repair facility. The purchaser is solely responsible for prepaying all shipping related costs to and from the repair facility. EdgeStar is not responsible for damage resulting from shipper mishandling or improper packaging. Do not return a defective product to the place of purchase. Products received without a return authorization number will be refused.

THIS WARRANTY IS IN LIEU OF ANY OTHER WARRANTY, EXPRESSED OR IMPLIED, INCLUDING WITHOUT LIMITATION, ANY WARRANTY OF MERCHANTABILITY OR FITNESS FOR A PARTICULAR PURPOSE. TO THE EXTENT ANY IMPLIED WARRANTY IS REQUIRED BY LAW, IT IS LIMITED IN DURATION TO THE EXPRESS WARRANTY PERIOD ABOVE. NEITHER THE MANUFACTURER NOR ITS DISTRIBUTORS SHALL BE LIABLE FOR ANY INCIDENTAL, CONSEQUENTIAL, INDIRECT, SPECIAL, OR PUNITIVE DAMAGES OF ANY NATURE, INCLUDING WITHOUT LIMITATION, LOST REVENUES OR PROFITS, OR ANY OTHER DAMAGE WHETHER BASED IN CONTRACT, TORT, OR OTHERWISE. SOME STATES DO NOT ALLOW THE EXCLUSION OF INCIDENTAL OR CONSEQUENTIAL DAMAGES, SO THE ABOVE EXCLUSION MAY NOT APPLY TO YOU. THIS WARRANTY GIVES YOU SPECIFIC LEGAL RIGHTS. YOU MAY HAVE OTHER RIGHTS THAT VARY FROM STATE TO STATE.

EDGESTAR[®]

EdgeStar Products
500 N. Capital of TX Hwy, Bldg 5
Austin, TX 78746

Toll Free: 1-866-319-5473
Web: <http://www.edgestar.com>
E-mail: service@edgestar.com

Register your product, download owner's manuals, access additional troubleshooting resources, and obtain more information on other great EdgeStar products on the web at: **<http://www.edgestar.com>**

Product contents and specifications may change without notice.

Copyright © 2014 Living Direct, Inc. All rights reserved.