

MSZ-GS24NA

24,000 BTU/H WALL-MOUNTED INDOOR UNIT



Job Name:

System Reference:

Date:



GENERAL FEATURES

- Slim wall-mounted indoor units provide zone comfort control
- Dual Barrier Coating applied to the heat exchanger, vanes and fan to prevent hydrophilic and hydrophobic dirt build-up
- Optional Microparticle Filter designed to capture PM2.5
- The outdoor unit powers the indoor unit, and should a power outage occur, the system is automatically restarted when power returns
- Quiet operation
- Smart Set: recalls a preferred preset temperature setting at the touch of a button
- Built-in backup/auxiliary heater control available
- Multiple fan speed options: Quiet, Low, Medium, High, Super-high, Auto
- Multiple control options available:
 - Back-lit screen handheld remote controller (provided with the unit)
 - kumo cloud® smart device app for remote access
 - Third-party interface options
 - Wired or wireless controllers

Specifications		System
Unit Type		MSZ-GS24NA
Cooling Capacity ^{1,3}	BTU/H	22,400
Heating Capacity ^{2,3}	BTU/H	27,600
Electrical	Voltage, Phase, Frequency	208/230, 1, 60
	Guaranteed Voltage Range	187 - 253
	Voltage: Indoor - Outdoor, S1-S2	208/230
	Voltage: Indoor - Outdoor, S2-S3	24
	Short-circuit Current Rating [SCCR]	5
Indoor Unit	MCA	1.0
	Fan Motor Full Load Amperage	0.5
	Fan Motor Output	56
	Airflow Rate at Cooling, Dry	361-456-565-701
	Airflow Rate at Cooling, Wet	325-410-509-631
	Airflow Rate at Heating, Dry	336-456-565-701
	Sound Pressure Level [Cooling]	34-41-47-53
	Sound Pressure Level [Heating]	32-41-47-52
	Drain Pipe Size	5/8 [15.88]
	Coating on Heat Exchanger	Dual Barrier Coating
	External Finish Color	Munsell 1.0Y 9.2/0.2
	Unit Dimensions	W x D x H: In. [mm] 43-5/16 x 9-3/8 x 12-13/16 [1,100 x 238 x 325]
	Package Dimensions	W x D x H: In. [mm] 45-1/2 x 12-3/4 x 15-1/2 [1,160 x 320 x 390]
	Unit Weight	37 [16.4]
	Package Weight	41 [18.4]
Refrigerant	Type R410A	
Piping	Gas Pipe Size O.D. [Flared]	5/8 [15.88]
	Liquid Pipe Size O.D. [Flared]	1/4 [6.35]

NOTES:
 Conditions ¹Cooling (Indoor // Outdoor) °F 80 DB, 67 WB // 95 DB, 75 WB
²Heating at 47°F (Indoor // Outdoor) °F 70 DB, 60 WB // 47 DB, 43 WB

³Capacity varies based on the number of indoor units operating and the model of the Multi-zone Outdoor Unit. For reference to connected capacity charts, please refer Multi-zone Outdoor Unit Operational Performance.

INDOOR UNIT ACCESSORIES: MSZ-GS24NA

Control Interface	BACnet® and Modbus® Interface	PAC-UKPRC001-CN-1
	CN24 Relay Kit	CN24RELAY-KIT-CM3
	IT Extender	PAC-WHS01IE-E
	kumo station® for kumo cloud®	PAC-WHS01HC-E
	System Control Interface	MAC-334IF-E
	Thermostat Interface	PAC-US444CN-1
	Thermostat Interface	PAC-US445CN-1
	USNAP Adapter	PAC-WHS01UP-E
	Wireless Interface for kumo cloud®	PAC-USWHS002-WF-2
Remote Sensor	Wired Remote Sensor	M21EAA307
	Wireless temperature and humidity sensor for kumo cloud®	PAC-USWHS003-TH-1
Wired Remote Controller	Deluxe Wired MA Remote Controller†	PAR-40MAAU
	Simple Ductless Wired Remote Controller	PAC-SDW01RC-1
	Simple MA Remote Controller†	PAC-YT53CRAU-J
	Touch MA Controller†	PAR-CT01MAU-SB
Wireless Remote Controller	kumo touch™ RedLINK™ Wireless Controller	MHK2
	Lockdown bracket for remote controller	RCMKP1CB
Condensate	Blue Diamond (Advanced) Mini Condensate Pump w/ Reservoir & Sensor (208/230V) [recommended]	X87-721
	Blue Diamond (MegaBlue Advanced) Condensate Pump w/ Reservoir & Sensor	X87-835
	Blue Diamond Alarm Extension Cable — 6.5 Ft.	C13-192
	Blue Diamond MultiTank — collection tank for use with multiple pumps	C21-014
	Blue Diamond Sensor Extension Cable — 15 Ft.	C13-103
	Drain Pan Level Sensor/Control	SS610E
	Fascia Kit for MicroBlue Pump, mounts the MicroBlue and sensor directly beneath indoor unit	T18-016
	Refco Condensate Pump (100-240 VAC)	GOBI-II
	Refco Condensate Pump (100-240 VAC) up to 120,000 BTU/H	COMBI
Saueremann Condensate Pump	SI30-230	
Disconnect Switch	(30A/600V/UL) [fits 2" X 4" utility box] - Black	TAZ-MS303
	(30A/600V/UL) [fits 2" X 4" utility box] - White	TAZ-MS303W
Filter	Electro Static Anti-allergy Enzyme Filter	MAC-2310FT-E
	Microparticle (PM2.5) Filter	MAC-EMF615FT-E

NOTES:

†Requires MAC-334IF-E

- M-Series EZ FIT® Recessed Ceiling Cassette, Floor-mount and Wall-mount
Allows indoor units to connect to an MA Controller:
 - Deluxe MA Remote Controller
 - Simple MA Controller
 - Touch MA Controller

INDOOR UNIT DIMENSIONS: MSZ-GS24NA

Unit: inch

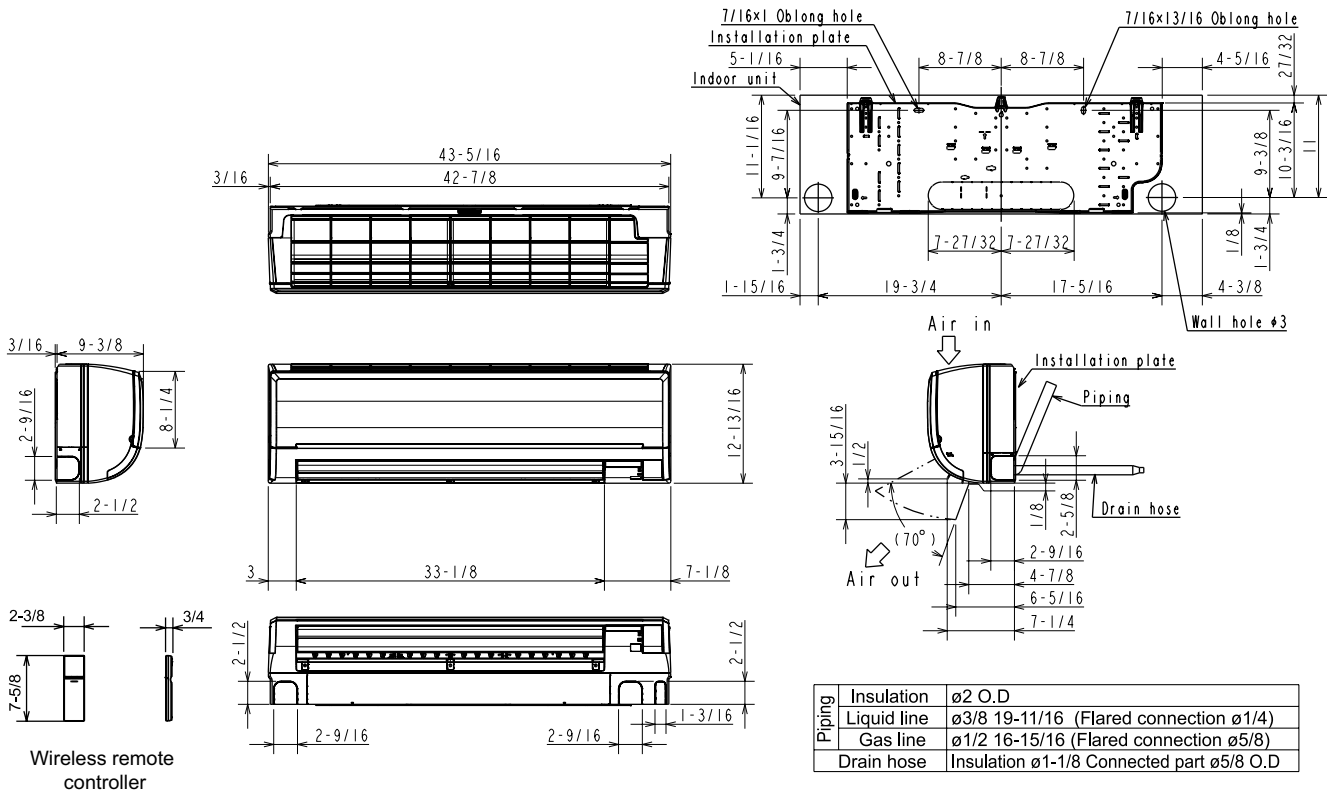

1340 Satellite Boulevard Suwanee, GA 30024
Toll Free: 800-433-4822 www.mehvac.com



FORM# MSZ-GS24NA-U1 - 202304