

Job Name:	
System Reference:	Date:



Indoor Unit: MFZ-KJ09NA-U1



Wireless Remote Controller

### SPECIFICATIONS:

Rated Capacity*		
Cooling <sup>1</sup>	Btu/h / W	9,000
Heating at 47° F <sup>2</sup>	Btu/h / W	11,000

Rating Conditions per AHRI Standard:

<sup>1</sup> Cooling | Indoor: 80° F(27° C)DB / 67° F(19° C)WB ; Outdoor: 95° F(35° C)DB / 75° F(24° C)WB  
<sup>2</sup> Heating at 47°F | Indoor: 70° F (21° C)DB / 60° F (16° C)WB ; Outdoor: 47° F (8° C)DB / 43° F (6° C)WB

For data on specific indoor units (all ducted, all non-ducted, and both ducted and non-ducted) combinations, see the MXZ Technical and Service Manual.

Applications should be restricted to comfort cooling only; equipment cooling applications are not recommended for low ambient temperature conditions.

Electrical Power Requirements	208 / 230V, 1-Phase, 60 Hz	
-------------------------------	----------------------------	--

Minimum Circuit Ampacity (MCA)	A	1.0
--------------------------------	---	-----

Blower Motor (ECM)	F.L.A.	0.62
--------------------	--------	------

Blower Motor Output	W	30
---------------------	---	----

Field Drainpipe Size O.D.	In.(mm)	5/8 (15)
---------------------------	---------	----------

Airflow Rate (Quiet - Lo - Med - Hi - Super Hi)			
Cooling	DRY	CFM	138-173-208-251-275
	WET		117-147-177-213-234
Heating	DRY		138-159-180-219-343

Sound Pressure Level (Quiet - Lo - Med - Hi - Super Hi)		
Cooling	dB(A)	21-25-30-34-38
Heating		21-24-27-32-41

Unit Dimensions (H x W x D)	In.(mm)	23-5/8 x 29-17/32 x 8-15/32 (600 x 750 x 215)
-----------------------------	---------	---

Package Dimensions (H x W x D)	In.(mm)	27-3/4 x 32-3/4 x 12 (693 x 816 x 275)
--------------------------------	---------	--

Unit/Package Weight		
Unit	Lbs.(kg)	33 (15)
Package	Lbs.(kg)	41 (18.5)

External Finish	Munsell 1.0Y 9.2 / 0.2	
-----------------	------------------------	--

Refrigerant Piping (Flared)		
Liquid (High Pressure)	In.(mm)	1/4 (6.35)
Gas (Low Pressure)		3/8 (9.52)

### ACCESSORIES:

#### Indoor Unit

- Condensate Pump (BlueDiamond X87-711/721; 115/230V)
- Condensate Pump (Sauermann SI30-115/230; 115/230V)
- Anti-Allergy Enzyme Filter (MAC-408FT-E)
- Platinum Catalyst Deodorizing Filter (MAC-308FT-E)
- Drain Pan Level Sensor (DPLS2)

#### Controls

- Wireless Controller (MHK1)
- Wired Remote Controller PAR-32MAA (Requires MAC-333IF-E)
- Wireless Interface for kumo cloud™ (PAC-WHS01WF-E)
- Thermostat Interface (PAC-US444CN-1)

# DIMENSIONS: MFZ-KJ09NA-U1

## MFZ-KJ09NA-U1

Unit: in.

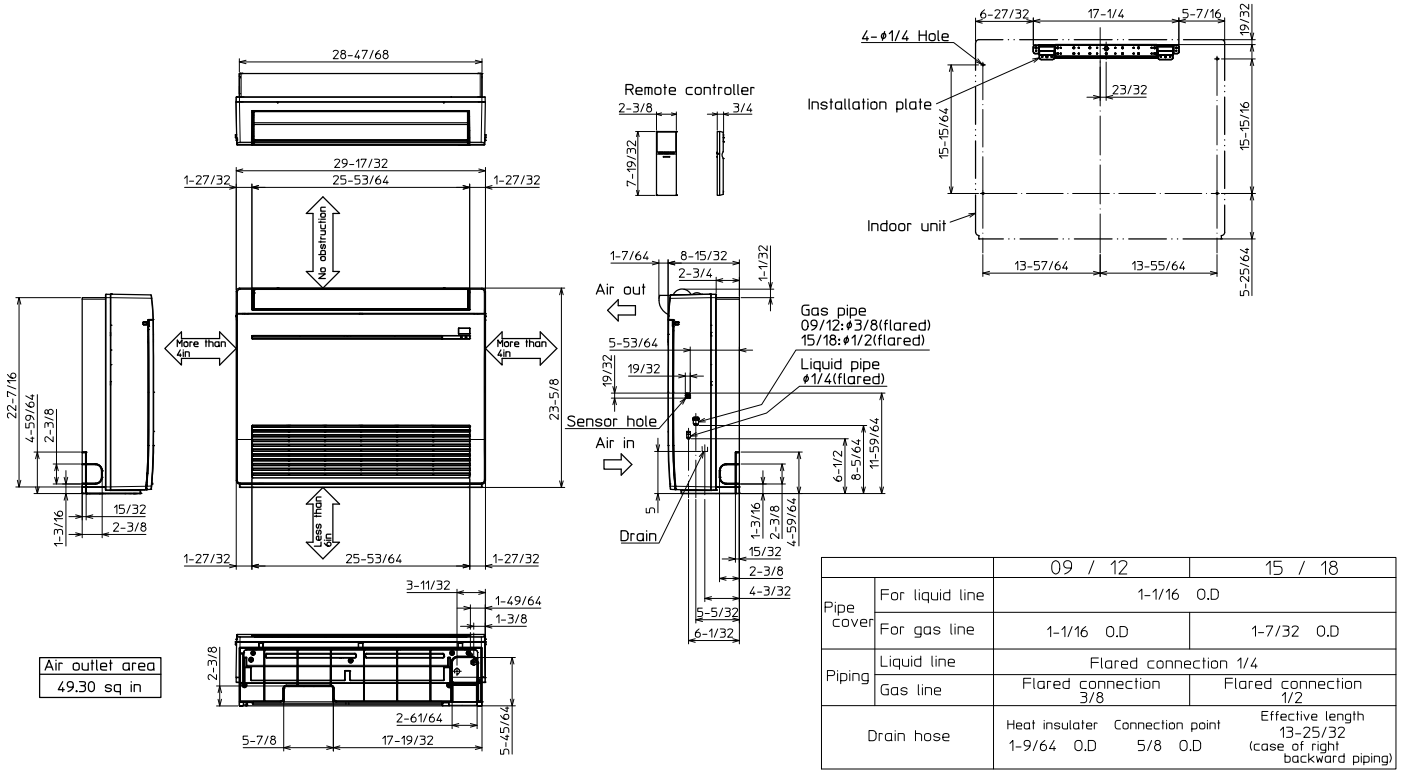

COOLING & HEATING

1340 Satellite Boulevard, Suwanee, GA 30024  
Toll Free: 800-433-4822 www.mehvac.com



Job Name:	Date:
System Reference:	



Indoor Unit: MFZ-KJ12NA-U1



Wireless Remote Controller

### SPECIFICATIONS:

Rated Capacity*		
Cooling <sup>1</sup>	Btu/h / W	12,000
Heating at 47° F <sup>2</sup>	Btu/h / W	13,000

Rating Conditions per AHRI Standard:

<sup>1</sup> Cooling | Indoor: 80° F(27° C)DB / 67° F(19° C)WB ; Outdoor: 95° F(35° C)DB / 75° F(24° C)WB

<sup>2</sup> Heating at 47°F | Indoor: 70° F (21° C)DB / 60° F (16° C)WB ; Outdoor: 47° F (8° C)DB / 43° F (6° C)WB

For data on specific indoor units (all ducted, all non-ducted, and both ducted and non-ducted) combinations, see the MXZ Technical and Service Manual.

Applications should be restricted to comfort cooling only; equipment cooling applications are not recommended for low ambient temperature conditions.

### ACCESSORIES:

#### Indoor Unit

- Condensate Pump (BlueDiamond X87-711/721; 115/230V)
- Condensate Pump (Sauermann SI30-115/230; 115/230V)
- Anti-Allergy Enzyme Filter (MAC-408FT-E)
- Platinum Catalyst Deodorizing Filter (MAC-308FT-E)
- Drain Pan Level Sensor (DPLS2)

#### Controls

- Wireless Controller (MHK1)
- Wired Remote Controller PAR-32MAA (Requires MAC-333IF-E)
- Wireless Interface for kumo cloud™ (PAC-WHS01WF-E)
- Thermostat Interface (PAC-US444CN-1)

Electrical Power Requirements	208 / 230V, 1-Phase, 60 Hz	
-------------------------------	----------------------------	--

Minimum Circuit Ampacity (MCA)	A	1
--------------------------------	---	---

Blower Motor (ECM)	F.L.A.	0.62
--------------------	--------	------

Blower Motor Output	W	30
---------------------	---	----

Field Drainpipe Size O.D.	In.(mm)	5/8 (15)
---------------------------	---------	----------

#### Airflow Rate (Quiet - Lo - Med - Hi - Super Hi)

Cooling	DRY	CFM	138-173-208-251-275
	WET		117-147-177-213-234
Heating	DRY		138-159-180-219-343

#### Sound Pressure Level (Quiet - Lo - Med - Hi - Super Hi)

Cooling	dB(A)	21-25-30-34-38
Heating		21-24-27-32-41

Unit Dimensions (H x W x D)	In.(mm)	23-5/8 x 29-17/32 x 8-15/32 (600 x 750 x 215)
-----------------------------	---------	---

Package Dimensions (H x W x D)	In.(mm)	27-3/4 x 32-3/4 x 12 (693 x 816 x 275)
--------------------------------	---------	--

#### Unit/Package Weight

Unit	Lbs.(kg)	33 (15)
Package	Lbs.(kg)	41 (18.5)

External Finish	Munsell 1.0Y 9.2 / 0.2	
-----------------	------------------------	--

#### Refrigerant Piping (Flared)

Liquid (High Pressure)	In.(mm)	1/4 (6.35)
Gas (Low Pressure)		3/8 (9.52)

# DIMENSIONS: MFZ-KJ12NA-U1

## MFZ-KJ12NA-U1

Unit: in.

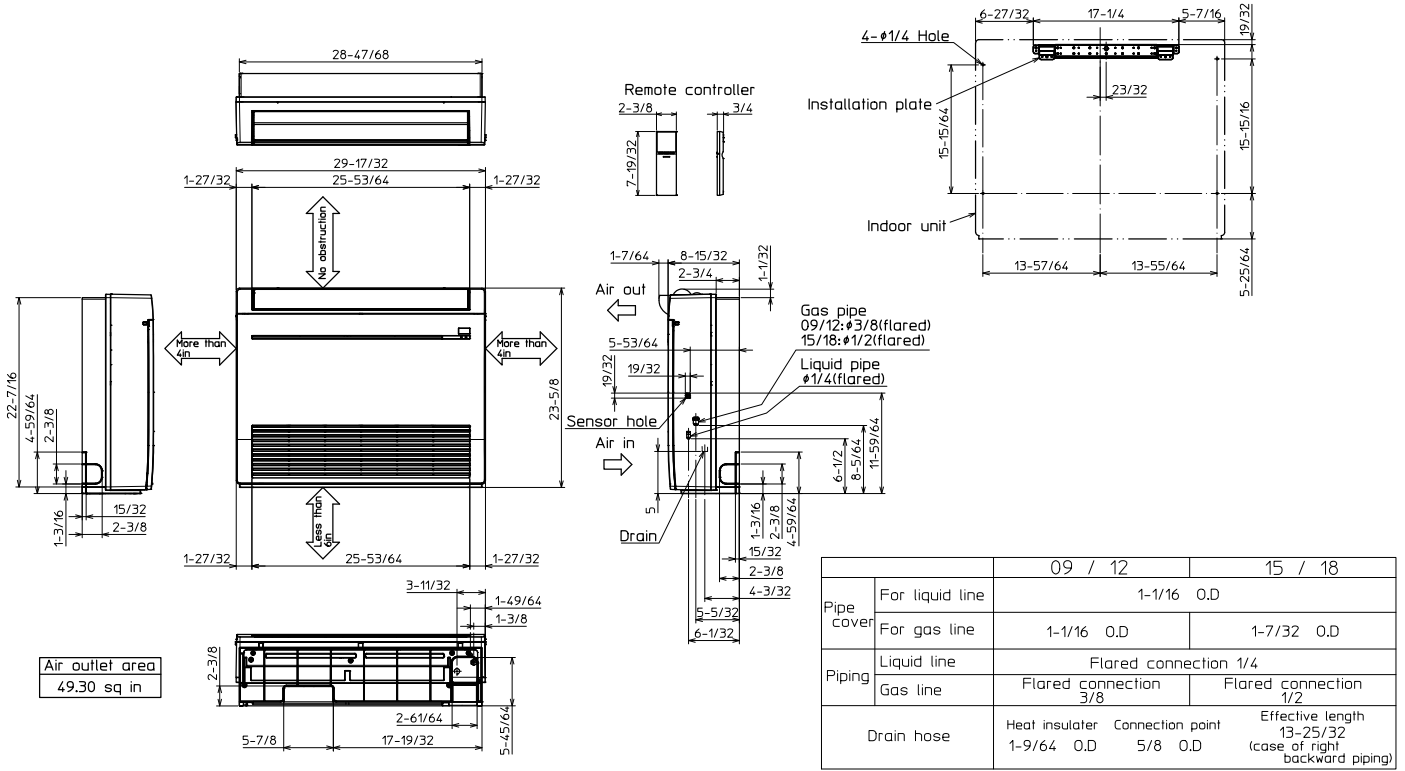

# MXZ-3C30NAHZ3 2.5-TON MULTI-ZONE INVERTER HEAT-PUMP SYSTEM



Job Name:

System Reference:

Date:



## FEATURES

- Variable speed INVERTER-driven compressor
- Built-in base pan heater
- Quiet outdoor unit operation as low as 54 dB(A)
- High pressure protection
- Compressor thermal protection
- Compressor overcurrent detection
- Fan motor overheating/voltage protection
- Hyper-heating performance offers 100% heating capacity at 5°F and 88% heating capacity at -13°F
- ENERGY STAR® certified (non-ducted)

ENERGY STAR products are third-party certified by an EPA-recognized Certification Body.

Specifications are subject to change without notice.

© 2022 Mitsubishi Electric Trane HVAC US LLC. All rights reserved.

## SPECIFICATIONS: MXZ-3C30NAHZ3

Cooling <sup>1</sup> (Non-Ducted // Mix // Ducted)	Maximum Capacity	BTU/H	23,600 // 23,600 // 23,600	
	Rated Capacity	BTU/H	28,400 // 27,800 // 27,400	
	Minimum Capacity	BTU/H	12,600 // 12,600 // 12,600	
	Maximum Power Input	W	3,770 // 3,770 // 3,770	
	Rated Power Input	W	2,272 // 2,467 // 2,661	
Heating at 47°F <sup>2</sup> (Non-Ducted // Mix // Ducted)	Power Factor (208V, 230V)	%	98.7, 98.7 // 98.7, 98.7 // 98.7, 98.7	
	Maximum Capacity	BTU/H	36,000 // 30,600 // 30,600	
	Rated Capacity	BTU/H	28,600 // 28,000 // 27,600	
	Minimum Capacity	BTU/H	11,400 // 11,400 // 11,400	
	Maximum Power Input	W	4,540 // 4,540 // 4,540	
Heating at 17°F <sup>3</sup> (Non-Ducted // Mix // Ducted)	Rated Power Input	W	2,096 // 2,142 // 2,187	
	Power Factor (208V, 230V)	%	97.8, 97.8 // 97.9, 97.9 // 97.9, 97.9	
	Maximum Capacity	BTU/H	28,600 // 28,100 // 27,600	
	Rated Capacity	BTU/H	18,000 // 17,750 // 16,500	
	Maximum Power Input	W	4,192 // 4,223 // 4,258	
Heating at 5°F <sup>4</sup> (Non-Ducted // Mix // Ducted)	Rated Power Input	W	1,990 // 1,992 // 1,993	
	Maximum Capacity	BTU/H	28,600 // 28,100 // 27,600	
Efficiency (Non-Ducted // Mix // Ducted)	Maximum Power Input	W	4,290 // 4,495 // 4,700	
	SEER		18.0 // 17.0 // 16.0	
	EER <sup>1</sup>		12.5 // 11.4 // 10.3	
	HSPF (IV)		11.0 // 10.4 // 9.8	
	COP at 47°F <sup>2</sup>		4.0 // 3.85 // 3.7	
	COP at 17°F at Maximum Capacity <sup>3</sup>		2.0 // 1.95 // 1.9	
Electrical	COP at 5°F at Maximum Capacity <sup>4</sup>		1.95 // 1.91 // 1.72	
	ENERGY STAR <sup>®</sup> Certified		Yes // No // No	
	Electrical Power Requirements	Voltage, Phase, Frequency	208/230, 1, 60	
	Guaranteed Voltage Range	V AC	187-253	
	Voltage: Indoor - Outdoor, S1-S2	V AC	208/230	
	Voltage: Indoor - Outdoor, S2-S3	V DC	24	
	Short-circuit Current Rating (SCCR)	kA	5	
	Recommended Fuse/Breaker Size	A	40	
	Recommended Wire Size	AWG	14	
	Minimum Circuit Ampacity	A	30.5	
Outdoor unit	Maximum Overcurrent Protection	A	40	
	Fan Motor Full Load Amperage	A	2.43	
	Airflow Rate (Cooling / Heating)	CFM	2,224 / 2,550	
	Refrigerant Control		LEV	
	Defrost Method		Reverse Cycle	
	Heat Exchanger Type		Plate fin coil	
	Sound Pressure Level, Cooling <sup>1</sup>	dB(A)	54	
	Sound Pressure Level, Heating <sup>2</sup>	dB(A)	58	
	Compressor Type		DC INVERTER-driven Twin Rotary	
	Compressor Model		MNB33FBTMC-L	
	Compressor Rated Load Amps	A	20	
	Compressor Locked Rotor Amps	A	28.8	
	Compressor Oil Type // Charge	oz.	FV50S // 37.2	
	Base Pan Heater		Built-in	
	Unit Dimensions	W: In. [mm]		37-13/32 [950]
		D: In. [mm]		13 [330]
		H: In. [mm]		41-17/64 [1,048]
	Package Dimensions	W: In. [mm]		41-3/8 [1,050]
D: In. [mm]			17-3/8 [440]	
H: In. [mm]			46-3/4 [1,190]	
Unit Weight	Lbs.[kg]		189 [86]	
Package Weight	Lbs.[kg]		213 [97]	
Outdoor unit operating temperature range	Cooling Intake Air Temp (Maximum / Minimum <sup>5</sup> )	°FDB	115 / 14	
	Cooling Thermal Lock-out / Re-start Temperatures	°FDB	10.4 / 14	
	Heating Intake Air Temp (Maximum / Minimum)	°FWB	65 / -13	
	Heating Thermal Lock-out / Re-start Temperatures	°FDB	-18 / -14	
Refrigerant	Charge	Lbs, oz	8.0, 13.0	
	Chargeless Piping Length	Ft. [m]	98.0 [30.0]	
	Additional Refrigerant Charge Per Additional Piping Length	oz./Ft. [g/m]	0.216 [20]	

### NOTES:

AHRI Rated Conditions

(Rated data is determined at a fixed compressor speed)

<sup>1</sup>Cooling (Indoor // Outdoor)

<sup>2</sup>Heating at 47°F (Indoor // Outdoor)

<sup>3</sup>Heating at 17°F (Indoor // Outdoor)

°F 80 DB, 67 WB // 95 DB, 75 WB

°F 70 DB, 60 WB // 47 DB, 43 WB

°F 70 DB, 60 WB // 17 DB, 15 WB

Conditions

<sup>4</sup>Heating at 5°F (Indoor // Outdoor)

°F 70 DB, 60 WB // 5 DB, 4 WB

\*Applications should be restricted to comfort cooling only; equipment cooling applications are not recommended for low ambient temperature conditions.

<sup>5</sup> 5°F DB - 115°F DB when optional wind baffles are installed

For actual capacity performance based on indoor unit type and number of indoor units connected, please refer to MXZ Operational Performance.

Although the maximum connectable capacity is 130%, the outdoor unit cannot provide more than 100% of the rated capacity. Please utilize this over capacity capability for load shedding or applications where it is known that all connected units will NOT be operating at the same time.

## SPECIFICATIONS: MXZ-3C30NAHZ3

Indoor unit connection	Maximum Number of Connected IDU		3
	Minimum Number of Connected IDU		2
	Minimum connected capacity	BTU/H	12,000
	Maximum connected capacity	BTU/H	36,000
Piping	Liquid Pipe Size O.D. (Flared)	In.[mm]	A,B,C: 1/4 [A,B,C: 6.35]
	Gas Pipe Size O.D. (Flared)	In.[mm]	A: 1/2; B,C: 3/8 [A: 12.72; B,C: 9.52]
	Total Piping Length	Ft. [m]	230 [70]
	Maximum Height Difference, ODU above IDU	Ft. [m]	49 [15]
	Maximum Height Difference, ODU below IDU	Ft. [m]	49 [15]
	Farthest Piping Length from ODU to IDU	Ft. [m]	82 [25]
	Maximum Number of Bends for IDU		70

**NOTES:**

AHRI Rated Conditions (Rated data is determined at a fixed compressor speed)	<sup>1</sup> Cooling (Indoor // Outdoor)	°F	80 DB, 67 WB // 95 DB, 75 WB
	<sup>2</sup> Heating at 47°F (Indoor // Outdoor)	°F	70 DB, 60 WB // 47 DB, 43 WB
	<sup>3</sup> Heating at 17°F (Indoor // Outdoor)	°F	70 DB, 60 WB // 17 DB, 15 WB

Conditions	<sup>4</sup> Heating at 5°F (Indoor // Outdoor)	°F	70 DB, 60 WB // 5 DB, 4 WB
------------	---	----	----------------------------

\*Applications should be restricted to comfort cooling only; equipment cooling applications are not recommended for low ambient temperature conditions.

<sup>A</sup> 5°F DB - 115°F DB when optional wind baffles are installed

For actual capacity performance based on indoor unit type and number of indoor units connected, please refer to MXZ Operational Performance. Although the maximum connectable capacity is 130%, the outdoor unit cannot provide more than 100% of the rated capacity. Please utilize this over capacity capability for load shedding or applications where it is known that all connected units will NOT be operating at the same time.

## OUTDOOR UNIT ACCESSORIES: MXZ-3C30NAHZ3

Air Outlet Guide	Air Outlet Guide (1 Piece)	PAC-SH96SG-E
Ball Valve	Refrigeration Ball Valve - 1/2"	BV12FFSI2
	Refrigeration Ball Valve - 1/4"	BV14FFSI2
	Refrigeration Ball Valve - 3/8"	BV38FFSI2
	Refrigeration Ball Valve - 5/8"	BV58FFSI2
Drain Socket	Drain Socket	PAC-SG60DS-E
Hail Guards	Hail Guard	HG-A1
M-NET Converter	M-NET Converter	PAC-IF01MNT-E
Mounting Pad	Condensing Unit Mounting Pad: 16" x 36" x 3"	ULTRILITE1
	Outdoor Unit 3-1/4 inch Mounting Base (Pair) - Plastic	DSD-400P
Port Adapter	Adaptor: 1/2" x 3/8"	MAC-A455JP-E
	Adaptor: 1/2" x 5/8"	MAC-A456JP-E
	Adaptor: 3/8" x 1/2"	MAC-A454JP-E
	Adaptor: 3/8" x 5/8"	PAC-SG76RJ-E
Stand	18" Single Fan Stand	QSMS1801M
	24" Single Fan Stand	QSMS2401M
	Condenser Wall Bracket	QSWB2000M-1
	Condenser Wall Bracket - Stainless Steel Finish	QSWBSS
	Outdoor Unit Stand — 12" High	QSMS1201M



