

Date: _____ For: File Resubmit
 PO No.: _____ Approval Other _____
 Architect: _____ GC: _____
 Engr: _____ Mech: _____
 Rep: _____
 (Company) (Project Manager)



LMU240HHV
Multi F with LGRED Heat Pump Outdoor Unit

Performance:

Cooling (Min-Rated-Max, Btu/h)	8,400 ~ 24,000 ~ 30,000
Heating (Min-Rated-Max, Btu/h)	10,248 ~ 26,000 ~ 31,200
Cooling Power Input (Min-Rated-Max, kW)	0.94 ~ 1.78 ~ 2.49
Heating Power Input (Min-Rated-Max, kW)	1.26 ~ 2.12 ~ 2.96

Cooling Nominal Test Conditions: Indoor: 80°F DB/67°F WB Outdoor: 95°F DB/75°F WB
 Heating Nominal Test Conditions: Indoor: 70°F DB/60°F WB Outdoor: 47°F DB/43°F WB

Electrical:

Power Supply (V ¹ /Hz/Ø)	208-230/60/1
MOP (A)	30
MCA (A)	19
Recommended Fuse Size (A)	25
Cooling Rated Amps (A)	15.73
Heating Rated Amps (A)	15.73
Compressor (A)	13
Fan Motor (A)	0.73

MOP - Maximum Overcurrent Protection MCA - Minimum Circuit Ampacity

Piping:

Refrigerant Charge (lbs.)	7.05
Liquid Line (in, OD)	Ø1/4 x 3
Vapor Line (in, OD)	Ø3/8 x 3
Max Total Piping ² (ft)	246.1
Max ODU to IDU Piping (ft)	82
Piping Length (no add'l refrigerant, ft)	73.8
Max Elevation between ODU and IDU (ft)	49.2
Max Elevation between IDU and IDU (ft)	24.6

ODU - Outdoor Unit IDU - Indoor Unit

Controls Features:

- Auto operation
- Auto restart operation
- Defrost/Deicing
- Inverter (variable speed compressor)
- Low ambient operation to 14F (cooling mode)
- Restart delay (3-minutes)
- Self diagnosis
- Soft start
- Factory installed Drain Pan Heater

Optional Accessories:

- PI-485 Integration Board - PMNFP14A1
- AC Smart IV - PACS4B000
- ACP IV - PACP4B000
- Power Distribution Indicator - PQNUD1S41
- MultiSITE™ CRC1 - PREMTBVCO
- MultiSITE CRC1+ - PREMTBVC1
- MultiSITE CM - PBACNBTR0A
- LonWorks® Gateway - PLNWKB100
- AC Smart IV BACnet® Gateway - PBACNA000
- ACP IV BACnet Gateway - PQNFB17C2
- Low Ambient Wind Baffle (Cooling operation to -4°F) - ZLABGP04A

For a complete list of available accessories, contact your LG representative.
 For continual product development, LG reserves the right to change specifications without notice.

Operating Range:

Cooling (°F DB)	14 to 118
Heating (°F WB)	-13 to +75

Unit Data:

Refrigerant Type	R410A
Refrigerant Control	EEV
Sound Pressure ³ (Cool/Heat) ±3 dB(A)	52 / 55
Net Unit Weight (lbs)	152.1
Shipping Weight (lbs)	165.3
Heat Exchanger Coating	GoldFin™
Min Number of Indoor Units	2
Max Number of Indoor Units	3

Compressor:

Quantity	1
Type	Twin Rotary
Oil/Type	FVC68D

Fan:

Type	Propeller
Quantity	1
Fan Motor/Drive	Brushless Digitally Controlled/Direct
Airflow Rate (CFM)	2295

Notes:

1. Acceptable operating voltage: 187V - 253V.
2. Piping lengths are equivalent.
3. Sound Pressure levels are tested in an anechoic chamber under ISO Standard 3745.
4. All power/communication cable to be minimum 18 American wire gage (AWG), 4-conductor, stranded, shielded or unshielded wire and must comply with applicable local and national code. If shielded, the wire must be grounded to the chassis at the outdoor unit only.
5. Power wiring cable size must comply with the applicable local and national code.
6. This data is rated 0 ft above sea level, with 25 ft of refrigerant line and a 0 ft level difference between outdoor and indoor units. All capacities are net with a combination ratio between 95 – 105%.
7. Must follow installation instructions in the applicable LG installation manual.
8. Refer to the Engineering Manual for combination capacity tables.
9. See Engineering Manual for sensible and latent capacities.
10. See Engineering Manual Capacity Tables for ODU capacity at design condition.



BACnet® is a registered trademark of ASHRAE. LonWorks is a trademark of Echelon Corporation.

LMU240HHV

Multi F with LGRED Heat Pump Outdoor Unit



LG

Life's Good

Tag #:

Date:

PO No.:

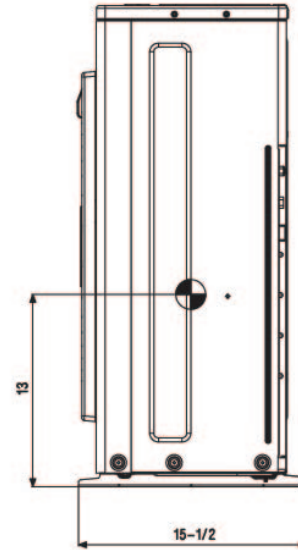
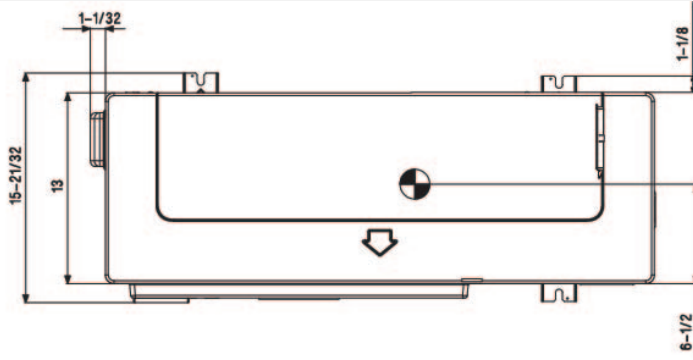

Unit: Inch

☉ Gravity point

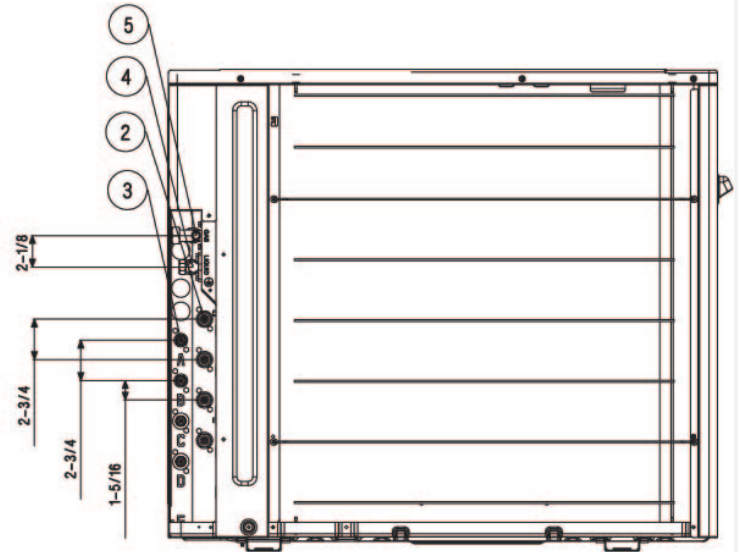
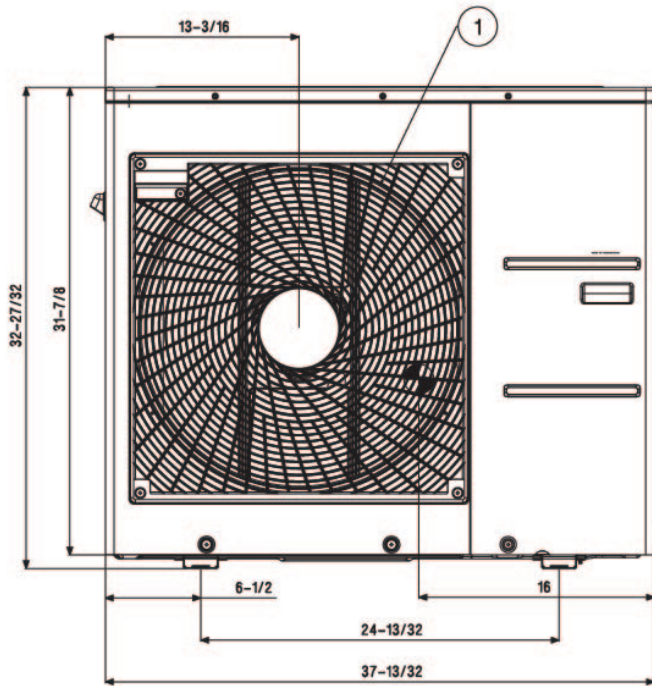

No.	Part Name
1	Air discharge grille
2	Gas pipe connection
3	Liquid pipe connection
4	Main service valve (Liquid)
5	Main service valve (Gas)

Job Name/Location:

Tag #:

Date:

For:	File	Resubmit
	Approval	Other_____

PO No.:



Architect: GC:

Engr: Mech:

Rep: (Company) (Project Manager)

LSN090HSV5
Multi F Wall Mounted High Efficiency Indoor Unit
9,000 Btu/h



Performance:

Nominal Cooling Capacity (Btu/h)	9,000
Nominal Heating Capacity (Btu/h)	10,900

Cooling Nominal Test Conditions:
Indoor: 80°F DB / 67°F WB
Outdoor: 95°F DB / 75°F WB

Heating Nominal Test Conditions:
Indoor: 70°F DB / 60°F WB
Outdoor: 47°F DB / 43°F WB

Electrical:

Power Supply (V)/Hz/Ø	208-230/60/1
Rated Amps (A)	0.4

Piping:

Installed Liquid Pipe (in., O.D.)	Ø1/4
Installed Vapor Pipe (in., O.D.)	Ø3/8
Liquid Connection (in., O.D.)	Ø1/4
Vapor Connection (in., O.D.)	Ø3/8
Drain (in., O.D. / I.D.)	27/32 , 5/8
Temperature Sensor	Thermistor

Controls Features:

- 4-Way auto swing
- 24-Hour on/off timer
- Auto operation
- Auto restart
- Chaos wind
- Inverter (variable speed fan)
- Compatible with Single Zone HSV5 Outdoor Units
- Jet cool/Jet heat
- 3M Micro Dust Filter
- Self-cleaning indoor coil
- Sleep mode
- Condensate sensor connection
- Built-in Wi-Fi via Smart ThinQ app

Included Accessories:

- Wireless Remote Controller — AKB74955602

Optional Accessories:

- MultiSITE™ CRC1 - PREMTBVC0
- MultiSITE CRC1+ - PREMTBVC1
- Dry Contact - PDRYCB300

Entering Mixed Air:

Cooling (°F WB)	57 ~ 77
Heating (°F DB)	59 ~ 81

Unit Data:

Refrigerant Type	R410A
Refrigerant Control	EEV
Sound Pressure (H/M/L) (±3 dB[A])²	36 / 32 / 27
Primary Filter	Washable Pre-filter
Secondary Filter	3M Micro Dust
Net Weight (lbs.)	18.3
Shipping Weight (lbs.)	23.4

Fan:

Type	Cross Flow
Quantity	1
Motor/Drive	Brushless Digitally Controlled/Direct
Air Flow H/M/L (CFM)	268 / 218 / 169

Notes:

1. Acceptable operating voltage: 187V-253V.
2. Sound Pressure levels are tested in an anechoic chamber under ISO Standard 3745.
3. See Engineering Manual for sensible and latent capacities.
4. All communication / connection (power) cable from the outdoor unit to the indoor unit is field supplied and must be a minimum of four-conductor, 18 AWG, stranded, shielded or unshielded (if shielded, it must be grounded to the chassis of the outdoor unit only), and must comply with applicable local and national codes.
5. Power wiring cable size must comply with the applicable local and national code.
6. The indoor unit comes with a dry helium charge.
7. Corresponding refrigerant piping length is in accordance with standard length of each outdoor unit and the level difference is 0 ft. All capacities are net with a combination ratio between 95 - 105%.
8. Must follow installation instructions in the applicable LG installation manual.



Job Name/Location:

Tag #:

Date:

For:	File	Resubmit
	Approval	Other_____

PO No.:

Architect: GC:

Engr: Mech:

Rep: (Company) (Project Manager)



LSN090HSV5
Multi F Wall Mounted High Efficiency Indoor Unit
9,000 Btu/h



Performance:

Nominal Cooling Capacity (Btu/h)	9,000
Nominal Heating Capacity (Btu/h)	10,900

Cooling Nominal Test Conditions:
Indoor: 80°F DB / 67°F WB
Outdoor: 95°F DB / 75°F WB

Heating Nominal Test Conditions:
Indoor: 70°F DB / 60°F WB
Outdoor: 47°F DB / 43°F WB

Electrical:

Power Supply (V)/Hz/Ø	208-230/60/1
Rated Amps (A)	0.4

Piping:

Installed Liquid Pipe (in., O.D.)	Ø1/4
Installed Vapor Pipe (in., O.D.)	Ø3/8
Liquid Connection (in., O.D.)	Ø1/4
Vapor Connection (in., O.D.)	Ø3/8
Drain (in., O.D. / I.D.)	27/32 , 5/8
Temperature Sensor	Thermistor

Controls Features:

- 4-Way auto swing
- 24-Hour on/off timer
- Auto operation
- Auto restart
- Chaos wind
- Inverter (variable speed fan)
- Compatible with Single Zone HSV5 Outdoor Units
- Jet cool/Jet heat
- 3M Micro Dust Filter
- Self-cleaning indoor coil
- Sleep mode
- Condensate sensor connection
- Built-in Wi-Fi via Smart ThinQ app

Included Accessories:

- Wireless Remote Controller — AKB74955602

Optional Accessories:

- MultiSITE™ CRC1 - PREMTBVC0
- MultiSITE CRC1+ - PREMTBVC1
- Dry Contact - PDRYCB300

Entering Mixed Air:

Cooling (°F WB)	57 ~ 77
Heating (°F DB)	59 ~ 81

Unit Data:

Refrigerant Type	R410A
Refrigerant Control	EEV
Sound Pressure (H/M/L) (±3 dB[A]) ²	36 / 32 / 27
Primary Filter	Washable Pre-filter
Secondary Filter	3M Micro Dust
Net Weight (lbs.)	18.3
Shipping Weight (lbs.)	23.4

Fan:

Type	Cross Flow
Quantity	1
Motor/Drive	Brushless Digitally Controlled/Direct
Air Flow H/M/L (CFM)	268 / 218 / 169

Notes:

1. Acceptable operating voltage: 187V-253V.
2. Sound Pressure levels are tested in an anechoic chamber under ISO Standard 3745.
3. See Engineering Manual for sensible and latent capacities.
4. All communication / connection (power) cable from the outdoor unit to the indoor unit is field supplied and must be a minimum of four-conductor, 18 AWG, stranded, shielded or unshielded (if shielded, it must be grounded to the chassis of the outdoor unit only), and must comply with applicable local and national codes.
5. Power wiring cable size must comply with the applicable local and national code.
6. The indoor unit comes with a dry helium charge.
7. Corresponding refrigerant piping length is in accordance with standard length of each outdoor unit and the level difference is 0 ft. All capacities are net with a combination ratio between 95 - 105%.
8. Must follow installation instructions in the applicable LG installation manual.



LSN090HSV5
Multi F Wall Mounted High Efficiency Indoor Unit
 9,000 Btu/h



Tag No.: _____

Date: _____

PO No.: _____

Unit : Inch (mm)

