

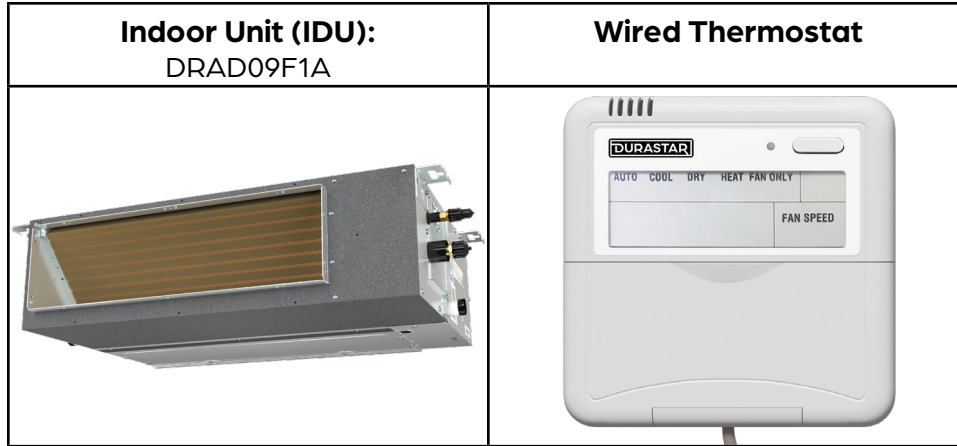

9,000 BTU/H SLIM DUCTED IDU

SUBMITTAL COVER SHEET

PROJECT NAME _____
 LOCATION _____
 ARCHITECT _____
 ENGINEER _____
 CONTRACTOR _____
 REFERENCE _____
 SUBMITTED BY _____ DATE _____



CAPACITIES		
Cooling Capacity (BTU/hr)	Rated	9000
Heating Capacity (BTU/hr)	Rated	10000

ELECTRICAL DATA	
Voltage/Phase/Frequency	208-230V, 1 Phase, 60 Hz

LINE SET REQUIREMENTS	
Connection Type	Flare
Liquid	Ø1/4" (Ø6.35mm)
Gas	Ø3/8" (Ø9.52mm)
Drain Port O.D. / Drain Hose I.D.	Ø1" (Ø25mm)

INDOOR UNIT DIMENSIONS		
Unit Dimensions	Width	27 9/16"
	Depth	19 15/16"
	Height	7 7/8"
Carton Dimensions	Width	33 7/8"
	Depth	21 1/4"
	Height	11 1/4"
Net Weight	39.0 lbs.	
Gross Weight	50.0 lbs.	

INDOOR UNIT FAN DATA		
Air Flow (CFM)	Low	177
	Medium	283
	High	353
Type	DC	
RLA	1.11	
Sound Pressure (dB(A))	Low	32
	Medium	35
	High	38
Static Pressure (in wg)	0-0.16	

PRODUCT FEATURES

- Wired Thermostat Included
- Auto Restart
- Auto Changeover
- 24-hour Timer





9,000 BTU/H SLIM DUCTED IDU

DIMENSIONS - DRAD09F1A

Unit and air outlet dimensions



Air inlet dimensions

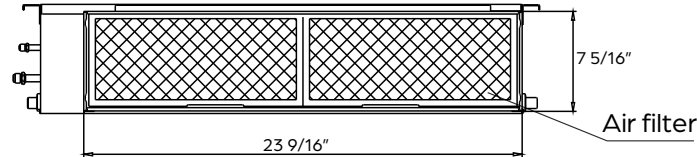

Mounting dimensions for ceiling bolts

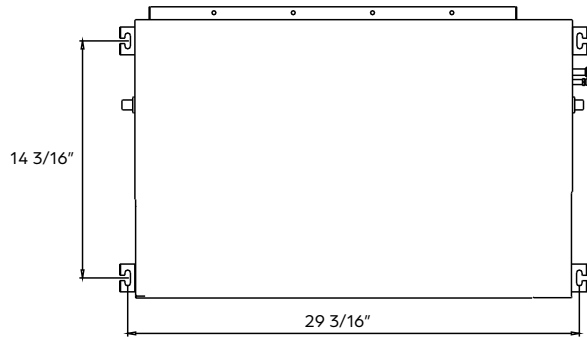

Installation clearances

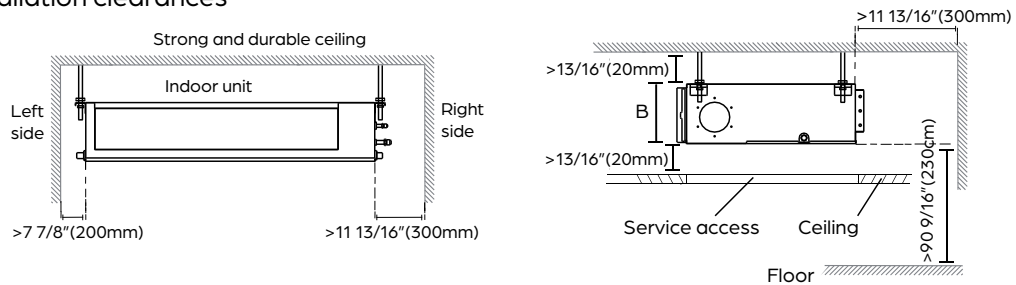

Maintenance access panel

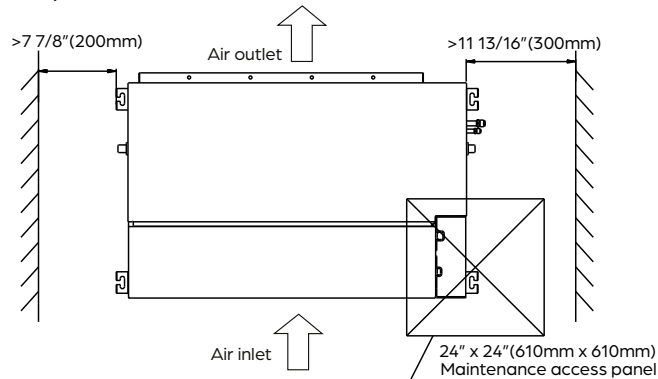



48,000 BTU/H MULTI-ZONE HEAT PUMP SYSTEM

SUBMITTAL COVER SHEET

PROJECT NAME _____

LOCATION _____

ARCHITECT _____

ENGINEER _____

CONTRACTOR _____

REFERENCE _____

SUBMITTED BY _____ DATE _____

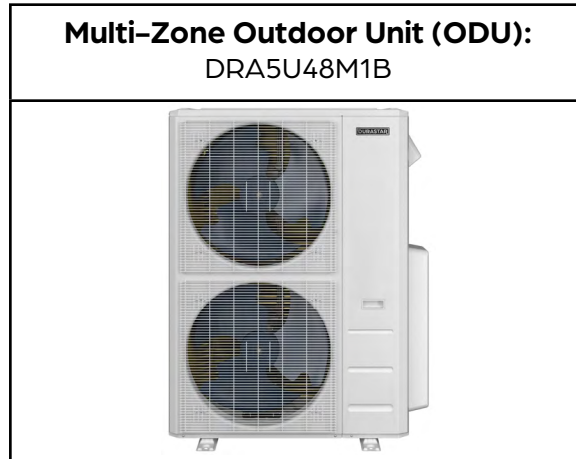

PRODUCT FEATURES

- Variable speed inverter compressor
- Quiet operation
- Low ambient heating down to -13 °F
- Low ambient cooling down to 5 °F
- Included base pan heater
- Auto restart
- Anti-corrosive coil coating
- Port adaptors included

SYSTEM DATA	
Refrigerant Type	R-410A
Refrigerant Charge (oz.)	162
Design Pressure (PSIG)	550/340
Outdoor Coil Coating	Golden Fin Coating

CAPACITIES		DUCTLESS	MIXED	DUCTED
Cooling (BTU/hr)	Rated ¹	48000	48500	49000
	at 5 °F ³	36410	35280	34150
	Minimum	11600	15500	19400
	Maximum	49700	50350	51000
Heating (BTU/hr)	Rated ²	48000	49000	50000
	at 5 °F ⁴	27040	28180	29320
	Minimum	33000	24250	15500
	Maximum	52900	54450	56000
Nominal IDU Capacity ⁵ (Min/Max)		24000/60000		

EFFICIENCY DATA	DUCTLESS	MIXED	DUCTED
SEER ²	21.10	20.80	20.50
EER ²	11.00	10.90	10.80
HSPF ²	9.50	9.60	9.70
SEER	21.00	20.75	20.50
EER	11.00	10.55	10.10
HSPF	10.50	11.00	11.50
COP at 47 °F	3.22	3.39	3.57
COP at 5 °F	1.63	1.67	1.70

Specifications are subject to change without notice.
© 2022 Ferguson Enterprises LLC
www.durastar.com





48,000 BTU/H MULTI-ZONE HEAT PUMP SYSTEM

SPECIFICATIONS - DRA5U48M1B

LINE SET REQUIREMENTS	
Connection Type	Flare
Liquid	5 x Ø1/4" (Ø6.35mm)
Gas	3 x Ø3/8" (Ø9.52mm) 2 x Ø1/2" (Ø12.7mm)
Refrigeration Adaptors Included	3 x 3/8"--1/2" 2 x 1/2"--3/8" 2 x 1/4"--3/8" 2 x 1/2"--5/8"
Minimum Indoor Units Connected	2
Pre-Charge Length	37.5'
Maximum Length (combined IDUs)	262'
Maximum Length (per IDU)	115'
Minimum Length (per IDU)	10'
Max. Height Differential between IDU and ODU	33'
Additional Refrigerant for Ø1/4" Liquid Pipe (oz./ft)	0.161
Additional Refrigerant for Ø3/8" Liquid Pipe (oz./ft)	0.322

ELECTRICAL DATA	DUCTLESS		DUCTED	
	Voltage/Phase/Frequency	208-230V, 1 Phase, 60 Hz		
Voltage Range	187-253V			
Recommended Breaker (Amps)	60			
Minimum Circuit Ampacity (Amps)	40			
Communication Wire Size	14*4 AWG Stranded			
Rated Current - Cooling (Amps) ¹	20			21.5
Rated Current - Heating (Amps) ²	20			18.2

¹ Measured at 95 °F.

² Measured at 47 °F.

³ Sensible Capacity: Indoor 80 °F DB, 67 °F WB // Outdoor 5 °F DB, 4 °F WB

⁴ Maximum Capacity: Indoor 70 °F DB, 67 °F WB // Outdoor 5 °F DB, 4 °F WB

⁵ If the total indoor unit load exceeds the nominal capacity of the outdoor unit, the practical output capacity of each indoor unit will be correspondingly reduced. This situation is very evident during heating mode.

OUTDOOR UNIT DATA		
Unit Dimensions	Width	37 1/2"
	Depth	16 5/16"
	Height	52 1/2"
Carton Dimensions	Width	43 1/8"
	Depth	19 1/2"
	Height	55 1/4"
Net Weight	225 lbs.	
Gross Weight	256 lbs.	
Cooling Operating Temperature	5 °F - 122 °F	
Heating Operating Temperature	-13 °F - 75 °F	
Airflow (CFM)	4500	
Sound Pressure (dB(A))	62	
Fan Speed (r/min)	Low	750
	Medium	800
	Medium	850
	High	900
Fan Motor Current Type	DC	

COMPRESSOR	
Type	DC Inverter Twin Cylinder Rotary
Oil Type	VG74
Oil Charge (oz.)	47 (1400 ml)



48,000 BTU/H MULTI-ZONE HEAT PUMP SYSTEM

ODU DIMENSIONS - DRA5U48M1B

Clearances

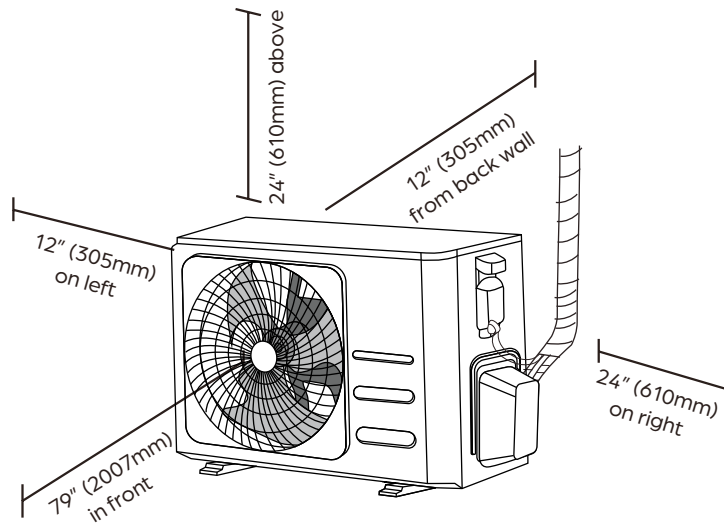

Dimensions

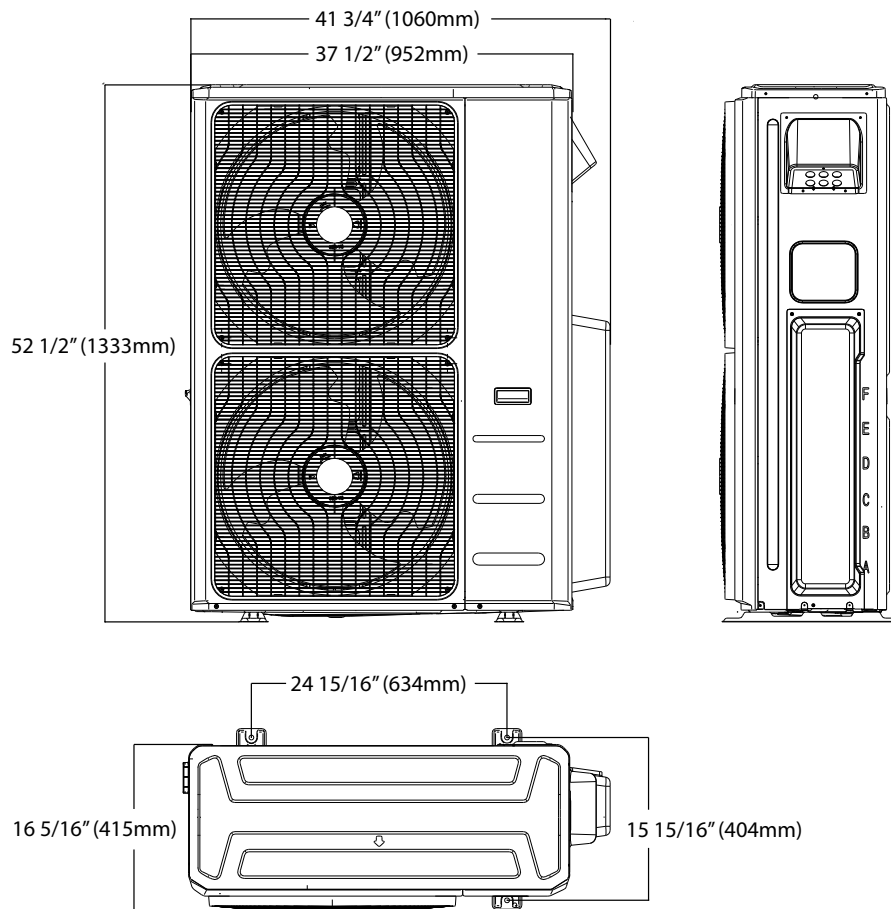

NOTE

Illustrations in this document are for explanatory purposes. The actual shape of your mini-split equipment may vary slightly.