



# 12,000 BTU/H FLOOR MOUNTED IDU

SUBMITTAL COVER SHEET

PROJECT NAME \_\_\_\_\_

LOCATION \_\_\_\_\_

ARCHITECT \_\_\_\_\_

ENGINEER \_\_\_\_\_

CONTRACTOR \_\_\_\_\_

REFERENCE \_\_\_\_\_

SUBMITTED BY \_\_\_\_\_ DATE \_\_\_\_\_

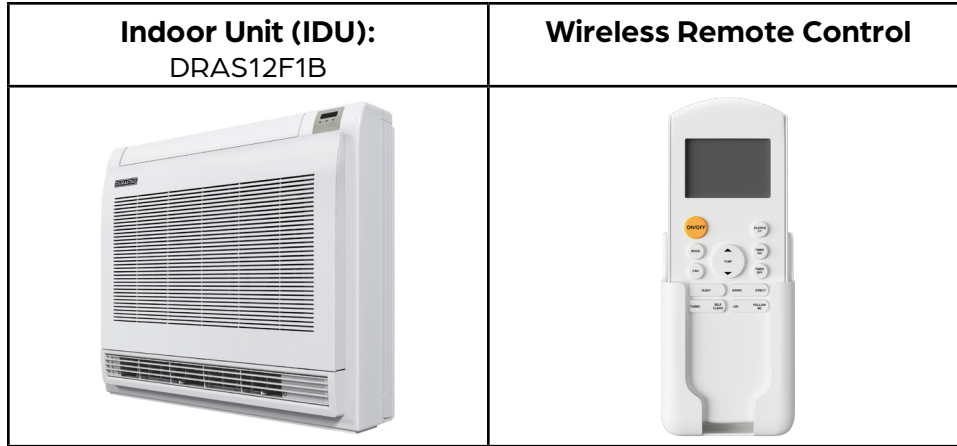

CAPACITIES		
Cooling Capacity (BTU/hr)	Rated	12000
Heating Capacity (BTU/hr)	Rated	12000

ELECTRICAL DATA	
Voltage/Phase/Frequency	208-230V, 1 Phase, 60 Hz

LINE SET REQUIREMENTS	
Connection Type	Flare
Liquid	Ø1/4" (Ø6.35mm)
Gas	Ø1/2" (Ø12.7mm)
Drain Port O.D. / Drain Hose I.D.	Ø5/8" (Ø16mm)

INDOOR UNIT FAN DATA		
Air Flow (CFM)	Low	248
	Medium	316
	High	365
Type	DC	
RLA	1.0	
Sound Pressure (dB(A))	Low	34.5
	Medium	43
	High	45

INDOOR UNIT DIMENSIONS		
Unit Dimensions	Width	27 9/16"
	Depth	8 1/4"
	Height	23 5/8"
Carton Dimensions	Width	30 11/16"
	Depth	11 13/16"
	Height	27"
Net Weight	32.6 lbs.	
Gross Weight	41.0 lbs.	

### PRODUCT FEATURES

- Wireless Remote Control with "Follow Me" Technology
- Auto Restart
- Auto Changeover
- 24-hour Timer
- Self Clean Function





# 12,000 BTU/H FLOOR MOUNTED IDU

DIMENSIONS - DRAS12F1A

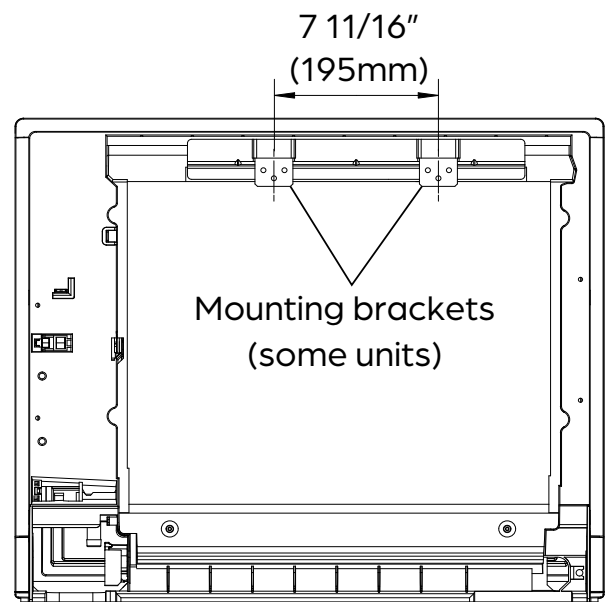
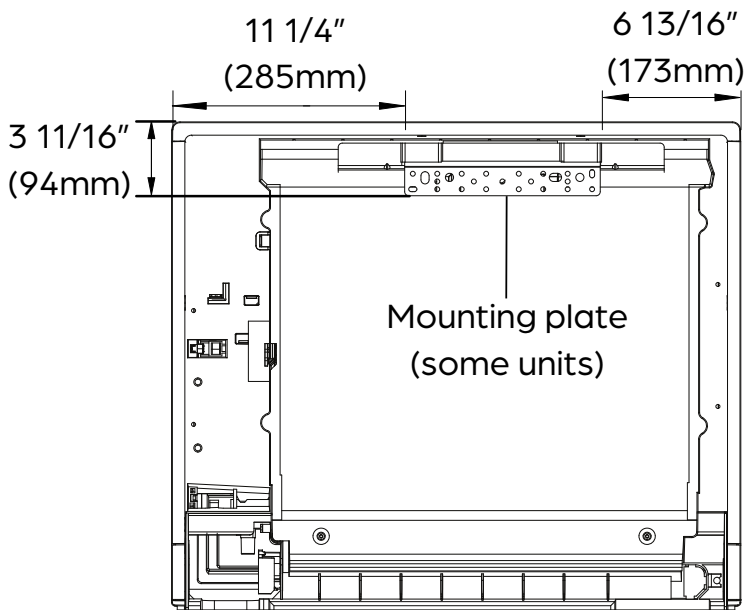
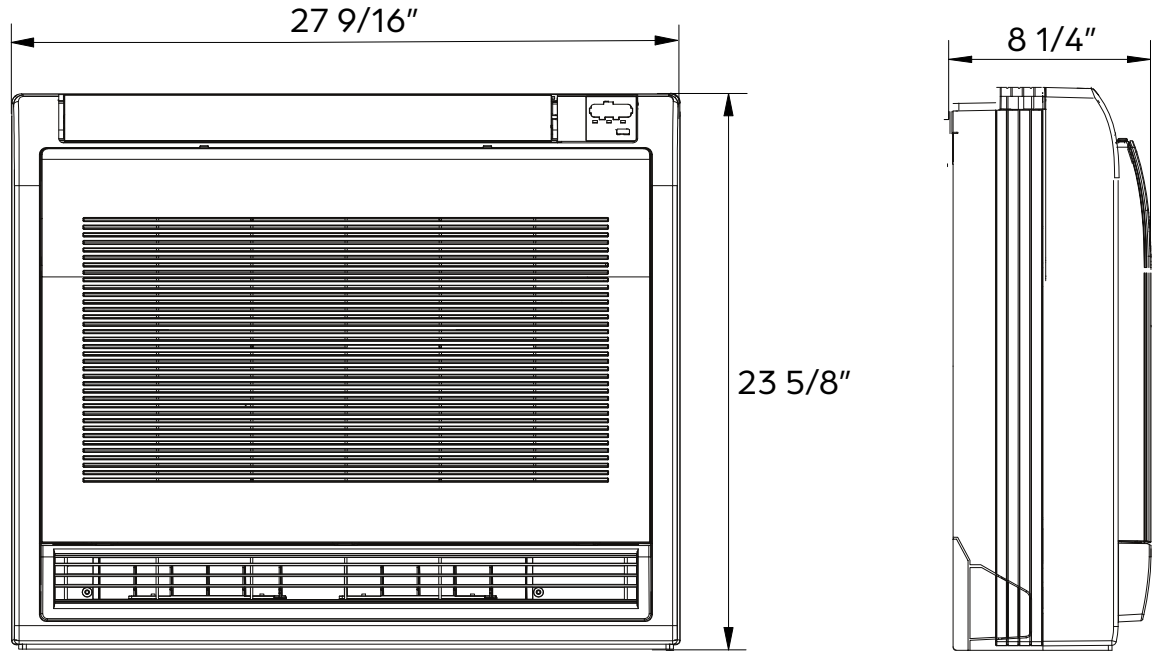



# 18,000 BTU/H MULTI-ZONE HEAT PUMP SYSTEM

SUBMITTAL COVER SHEET

PROJECT NAME \_\_\_\_\_

LOCATION \_\_\_\_\_

ARCHITECT \_\_\_\_\_

ENGINEER \_\_\_\_\_

CONTRACTOR \_\_\_\_\_

REFERENCE \_\_\_\_\_

SUBMITTED BY \_\_\_\_\_ DATE \_\_\_\_\_

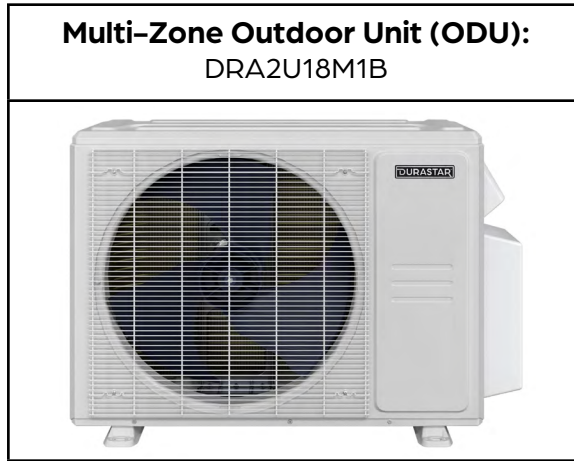

### PRODUCT FEATURES

- Variable speed inverter compressor
- Quiet operation
- Low ambient heating down to -13 °F
- Low ambient cooling down to 5 °F
- Included base pan heater
- Auto restart
- Anti-corrosive coil coating
- Port adaptors included

SYSTEM DATA	
Refrigerant Type	R-410A
Refrigerant Charge (oz.)	65.26
Design Pressure (PSIG)	550/340
Outdoor Coil Coating	Golden Fin Coating

CAPACITIES		DUCTLESS	MIXED	DUCTED
Cooling (BTU/hr)	Rated <sup>1</sup>	18000	18000	18000
	at 5 °F <sup>3</sup>	16100	16320	16540
	Minimum	4950	4400	3850
	Maximum	23000	22700	22400
Heating (BTU/hr)	Rated <sup>2</sup>	19000	19000	19000
	at 5 °F <sup>4</sup>	11280	12290	13300
	Minimum	4900	4975	5050
	Maximum	23000	23700	24400
Nominal IDU Capacity <sup>5</sup> (Min/Max)		12000/24000		

EFFICIENCY DATA	DUCTLESS	MIXED	DUCTED
SEER2	21.00	20.00	19.00
EER2	12.50	12.25	12.00
HSPF2	10.20	10.00	9.80
SEER	21.50	20.25	19.00
EER	12.50	12.25	12.00
HSPF	10.60	10.70	10.80
COP at 47 °F	3.70	3.70	3.80
COP at 5 °F	1.85	1.94	2.03

Specifications are subject to change without notice.  
 © 2022 Ferguson Enterprises LLC  
 www.durastar.com





# 18,000 BTU/H MULTI-ZONE HEAT PUMP SYSTEM

SPECIFICATIONS - DRA2U18M1B

LINE SET REQUIREMENTS	
Connection Type	Flare
Liquid	2 x Ø1/4" (Ø6.35mm)
Gas	2 x Ø3/8" (Ø9.52mm)
Refrigeration Adaptors Included	2 x 3/8"--1/2"
Minimum Indoor Units Connected	2
Pre-Charge Length	49'
Maximum Length (combined IDUs)	131'
Maximum Length (per IDU)	82'
Minimum Length (per IDU)	10'
Max. Height Differential between IDU and ODU	49'
Additional Refrigerant for Ø1/4" Liquid Pipe (oz./ft)	0.161

ELECTRICAL DATA	DUCTLESS	DUCTED
Voltage/Phase/Frequency	208-230V, 1 Phase, 60 Hz	
Voltage Range	187-253V	
Recommended Breaker (Amps)	25	
Minimum Circuit Ampacity (Amps)	18	
Communication Wire Size	14*4 AWG Stranded	
Rated Current - Cooling (Amps) <sup>1</sup>	6.4	6.7
Rated Current - Heating (Amps) <sup>2</sup>	6.7	6.5

<sup>1</sup> Measured at 95 °F.

<sup>2</sup> Measured at 47 °F.

<sup>3</sup> Sensible Capacity: Indoor 80 °F DB, 67 °F WB // Outdoor 5 °F DB, 4 °F WB

<sup>4</sup> Maximum Capacity: Indoor 70 °F DB, 67 °F WB // Outdoor 5 °F DB, 4 °F WB

<sup>5</sup> If the total indoor unit load exceeds the nominal capacity of the outdoor unit, the practical output capacity of each indoor unit will be correspondingly reduced. This situation is very evident during heating mode.

OUTDOOR UNIT DATA		
Unit Dimensions	Width	35 1/16"
	Depth	13 7/16"
	Height	26 1/2"
Carton Dimensions	Width	40 9/16"
	Depth	17 1/4"
	Height	29 1/2"
Net Weight	100.3 lbs.	
Gross Weight	108.7 lbs.	
Cooling Operating Temperature	5 °F - 122 °F	
Heating Operating Temperature	-13 °F - 75 °F	
Airflow (CFM)	1765	
Sound Pressure (dB(A))	58.5	
Fan Speed (r/min)	Low	500
	High	750
Fan Motor Current Type	DC	

COMPRESSOR	
Type	DC Inverter Twin Cylinder Rotary
Oil Type	VG74
Oil Charge (oz.)	15.2 (450 ml)



# 18,000 BTU/H MULTI-ZONE HEAT PUMP SYSTEM

ODU DIMENSIONS - DRA2U18M1B

## Clearances

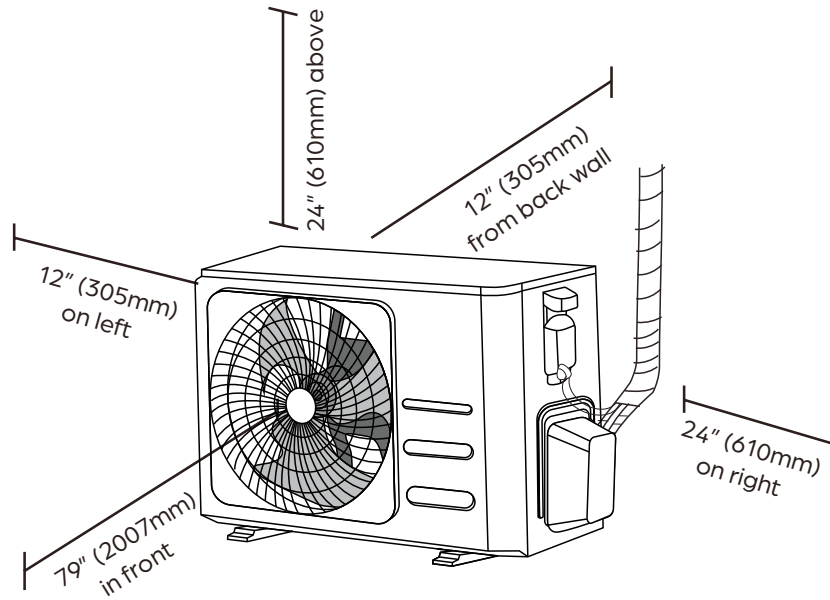

## Dimensions

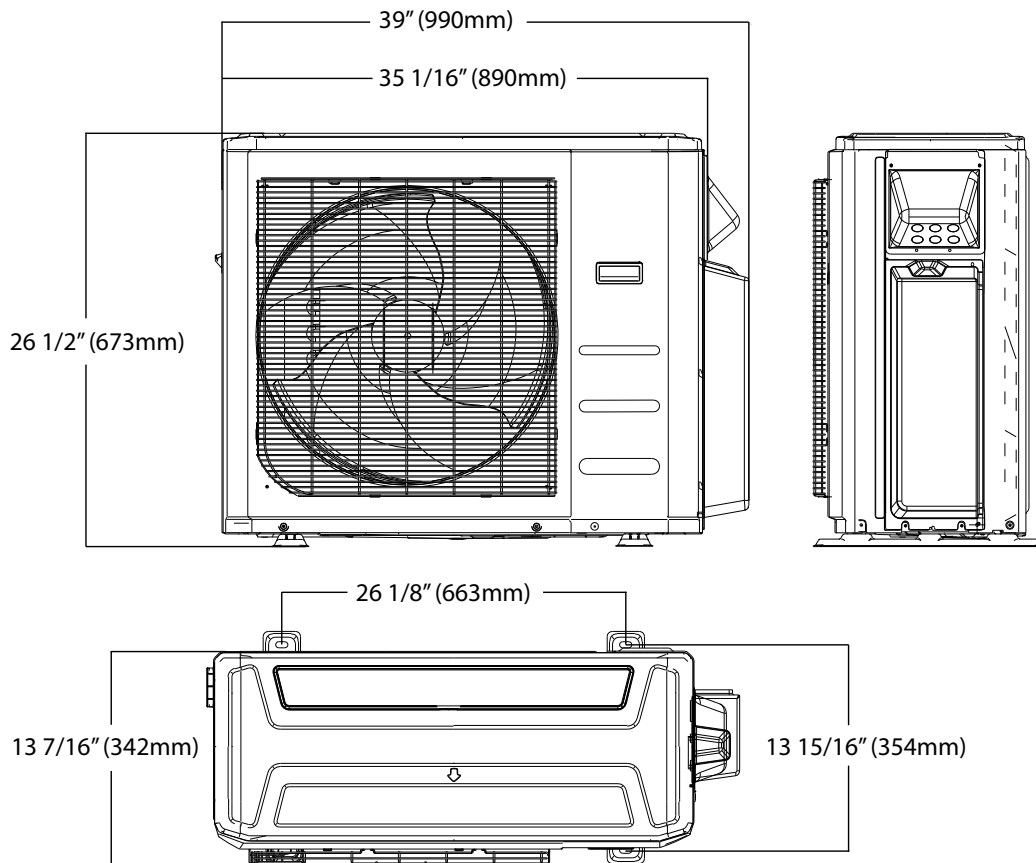

### NOTE

Illustrations in this document are for explanatory purposes. The actual shape of your mini-split equipment may vary slightly.