

Thermal Track[®]

Design and Application Guide

www.zurnpex.com

THERMAL TRACK®
Design and Application Guide

CONTENTS

Thermal Track – How It Works2
 Thermal Track Warmcoat™2
 Advantages of Thermal Track3
 Chart C1 – Steady State Performance of Thermal Track4
 Average Water Temperatures4
 Steady State Performance4
 Heat Loss4
 R-Value of Floor Assemblies5
 Components5
 Thermal Track Product Handling Information6
 Thermal Track Storage6
 Estimating the Required Number of Thermal Track Panels6
 Tubing6
 Chart C2 – 3/8" Zurn PEX Flow Data7
 Spacing of Panels7
 Overview of Floor Surface Requirements7
 Equipment Required for Installation8
 Layout and Installation9
 Detail Showing Spacing Between Panels10
 Additional Application Guidelines11
 Gluing and Screwing Patterns12
 Alternative to Gluing and Screwing12
 Connections at Manifold13
 Note on Caulking Grooves13
 Application – Carpet Over Subfloor13
 Application – Laminate or Vinyl Over Subfloor14
 Application Options – Wood Floors Over Thermal Track16
 Application – Hardwoods Over Subfloor17
 Considerations with Traditional Wood Flooring
 Over Thermal Track19
 Application – Tile or Stone Over Subfloor20
 Tile and Stone: More Details21
 Application – Over Slab22
 Application – Wall or Ceiling24
 Cautions and Limitations of Use25
 Typical R-values of flooring goods & materials (Appendix A)26

THERMAL TRACK – HOW IT WORKS

Thermal Track panels are typically glued and screwed or stapled to a wood subfloor. Then Zurn PEX pipe, which will carry warm water, is snapped into the groove. Heat is transferred from the pipe to the aluminum and the panel. Thermal Tracks are manufactured from MDF (medium density fiber board), or dense OSB (oriented strand board) which are relatively conductive wood products weighing 44-50 lbs. per cubic foot. The panel is grooved and then laminated with a top layer of highly conductive aluminum to efficiently disperse and transfer heat away from the groove to the surface area of the whole board.



Figure A-1 A cross section, showing Zurn PEX pipe in groove and panel with aluminum top layer.

Acceleration is a measure of how fast a radiant heating systems responds. Aluminum is approximately 1000 times more conductive than wood. The layer of aluminum on Thermal Track and in the groove, significantly enhances the transfer of heat and evenness of heat distribution of the panel. See Figure A-2 to see how the heat transfers through Thermal Track. The thin profile and relatively high density contributes to the superior acceleration and deceleration of Thermal Track.

Traditional radiant heating systems in concrete work well but they must first charge a large thermal mass before heat will begin coming out of the panel. They accelerate and decelerate very slowly due to the large thermal mass and they can be hard to control. Thermal Track, being thin but relatively dense and aided by its conductive aluminum layer responds very rapidly. This results in greatly improved response time with almost no overheating since there is almost no “thermal lag” to overcome. Thermal Track can be controlled with standard set back thermostats.

THERMAL TRACK WARMCOAT™

The Thermal Track Warmcoat aluminum top layer provides multiple benefits. It is highly conductive. The Warmcoat aluminum layer is also moisture resistant. Thermal Track is manufactured to meet the less than 0.3 ppm formaldehyde Federal Housing Authority (FHA) standards. Independent laboratory tests with 144°F water indicate, that due to the aluminum Warmcoat layer, Thermal Track has virtually no detectable levels of outgassing.

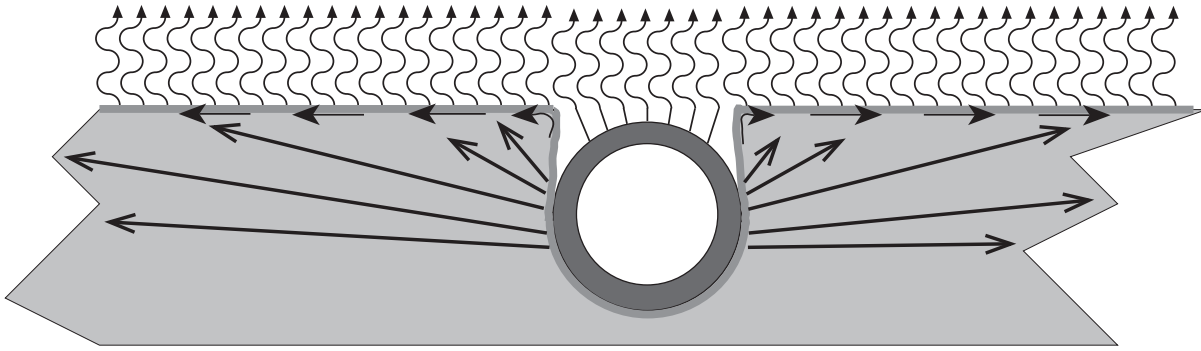

Figure A-2 Thermal Track Heat Transfer

Rapid acceleration from the aluminum layer and just enough thermal mass in a thin dense board make the radiant heating system stable and easy to control.

THE ADVANTAGES OF THERMAL TRACK

Hydronic radiant heating is the most comfortable and efficient way to heat your home or building with numerous construction benefits and unsurpassed flexibility in zoning. For many years, typical applications for radiant systems involved embedding tubing in concrete slabs or pouring “lightweight concrete” over tubing stapled to subfloors. The lack of good alternatives to these types of systems permitted designers to overlook the limitations and disadvantages of concrete systems. Thermal Track is designed for the application of hydronic radiant tubing over a variety of construction types. Thermal Track may be used in new construction and is advantageous in the growing retrofit market. While only adding 5/8" to the existing floor height, Thermal Track provides a superior performing radiant heating system. Application of the system is made easy because only three types of panels are required for installation.

The Thermal Track radiant floor heating system provides an attractive alternative to concrete with numerous advantages:

- Superior performing, high density thermal mass
- Excellent response time to heat up/cool down
- Easy layout and installation
- Lightweight – 5 times lighter than concrete
- Even distribution of heat
- Superb design and zoning flexibility
- Excellent compatibility with floor coverings
- Lightweight: reduces need for structural upgrades

Response Time: In these side-by-side drawings, notice how pipe in 4 inches of cement must overcome much more mass before it begins giving off heat.

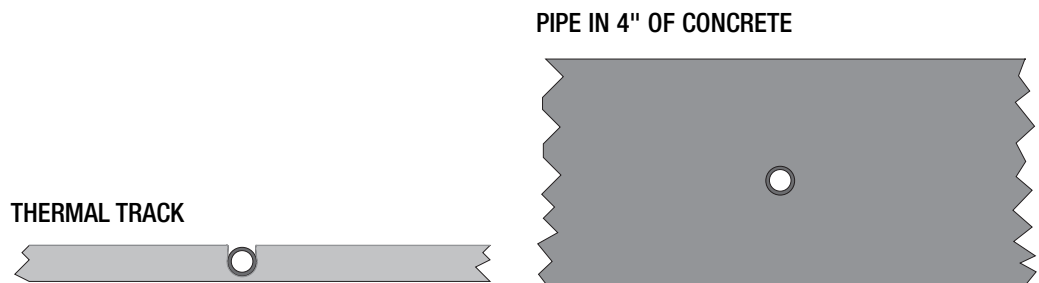

Figure A-3

Installers Note: Remember average water temperature means the average of the supply and return water temperatures flowing to and from the loop. Typically, Thermal Track is designed with a 20°F temperature drop. This means the supply water temperature would typically be 10°F higher than the average water temperature.

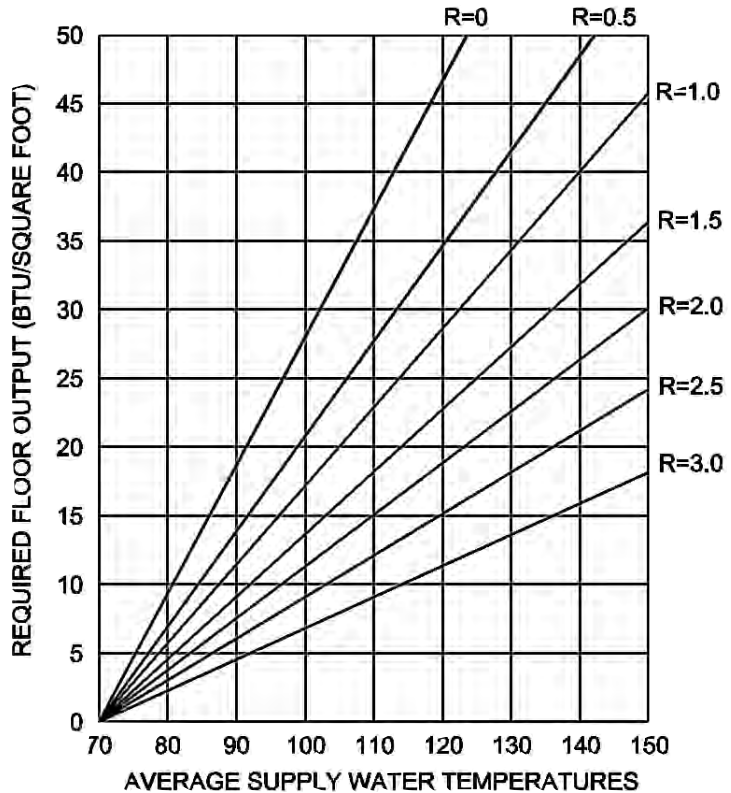

Chart C-1

STEADY STATE PERFORMANCE

Chart C-1 shows the steady state performance of Thermal Track. To the left are the BTU/sq.ft./hour; the lines represent the resistance of the floor coverings on top of Thermal Track, and on the bottom is the average water temperature required to achieve the output. The chart is read by selecting the correct BTU requirement and then moving horizontally until the line indicating the correct R-Value of the floor assembly on top of Thermal Track is encountered. At that point, drop down vertically to see average water temperature. (See Appendix A on page 26 for typical R-values of flooring goods and materials.)

Installers and Designers Note:

Perform the heat loss of the structure at the design stage. This way selection of floor coverings can be made with the requirements of the system in mind. If the heat loss is too high, add insulation or auxiliary heat. In a very high heat loss room, Thermal Track might be added to the walls or ceilings for extra heat.

HEAT LOSS

As with all floor heating jobs, a detailed and accurate heat loss **must** be calculated in order to determine proper design conditions. Refer to the 1999 Radiant Panel Association Guidelines For The Installation Of Radiant Panel Systems for standards on insulation and heat loss. The maximum recommended supply water temperature for Thermal Track is 150°F.

R-VALUE OF FLOOR ASSEMBLIES

While Thermal Track will work with a wide variety of floor coverings over the top of the panels it is important to realize that all floor coverings offer a resistance to heat transfer as measured typically by their R-Value. As with all radiant systems, the higher the R-Value of the floor covering the higher the average water temperature it takes to overcome this resistance and to generate the desired amount of heat. If the R-value of any covering on top of Thermal Track becomes excessive, as in any radiant heating system, performance will be compromised due to lack of heat transfer, or by exceeding the 150°F maximum supply water temperature. Chart C-1 can be used to estimate system output with different floor coverings.

Installers and Designers Note: Learn about the resistance of the intended floor coverings at the design stage and make sure that they are within the requirements of the system.

COMPONENTS

Thermal Track comes in three different panel configurations. These are “straight,” “utility,” and “combination” panels. They are assembled to make a channel for the pipe. Thermal Track panels cut easily with a circular saw.

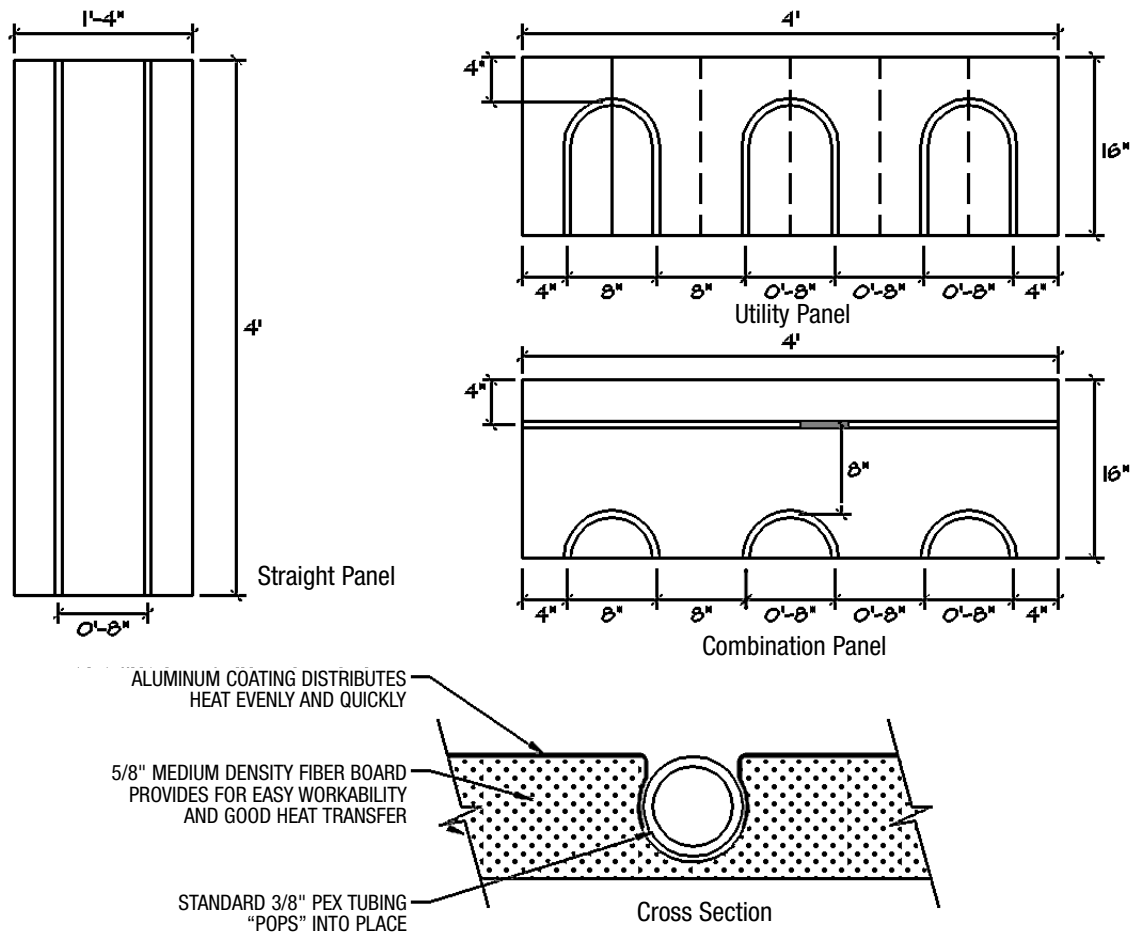

Figure A-4 Thermal Track Components

THERMAL TRACK PRODUCT HANDLING INFORMATION

Nominal Dimensions: Each panel is 16" x 48" x 5/8" thick, or 5.333 square feet per panel

Weight: Approximately 2.5 lbs. per square foot, 13.3 lbs. per panel

Pallet Size: 4' x 4' x 24" tall (3 Thermal Track panels to a row, 32 rows high)

Approximate Pallet Weight: 1280 lbs.

Approximate Truckload Quantities: 16,885.44 square feet or 33 pallets, 42,214 lbs.

Pallet Appearance: Shrink wrapped, corner protected, color-coded corners by part number

Recommended Product Mix: Straight 70%, Combination 15%, Utility 15%; Allow 10% overage.

THERMAL TRACK STORAGE

Thermal Track should be stored in a temperate, dry place (40°F-90°F). Avoid prolonged exposure to sunlight. Do not store in a damp location.

ESTIMATING THE REQUIRED NUMBER OF THERMAL TRACK PANELS

For simple and fast installation, it is highly recommended that a full Thermal Track layout be used which indicates precise panel and tubing layout. A plan is recommended for the first few jobs.

For experienced installers, calculate the net square footage of each room and multiply by the following factors: Straight – 0.133 Utility – 0.028
Combination – 0.028

Example: For a 600 sq. ft. room, multiplying 600 by 0.133 gives approximately 80 straight panels. Multiplying 600 by 0.028 gives 17 Utility pieces. Multiplying 600 by 0.028 gives 17 Combination panels. It is always recommended that a 10% material overage be added to the estimation.

TUBING

Thermal Track is designed for use with 3/8" nominal ASTM F-876 Zurn PEX (cross-linked polyethylene) with an average outer diameter measuring .5". Loops shall never be over 250 feet including the leaders to manifolds. For areas with heat loss greater than 25 BTU/sq. ft., loops shall never be over 200 feet. This is due to high pressure drops and water velocity as shown in Chart C-2* below (shaded area over 25 BTU/sq. ft.). Friction losses in chart are approximate; actual friction losses depend on fluid viscosity and temperature.

TUBING, cont'd.

Once the room square footage is determined, multiply the total by 1.5.

*Shaded area in Chart C-2 – 250' Loop (shown below) indicates high pressure drop. It is recommended to use the shorter 200' loop length in this case, as shown in the second chart.

Example: For a 600 sq. ft. room, multiplying 600 by 1.5 gives 900 lineal feet of 3/8" Zurn PEX tubing. This room would require four loops at 225 feet each. Alternatively, three 250-foot loops and one 150-foot loop could be used, provided that means were provided to balance the flow to the different loops by balancing valves.

Thermal Track 250' Loops 20°F Temp. Drop*

BTU/Sq. Ft.	10	15	20	25	30	35	40
Friction Loss (Ft. Head)	2.22	4.7	8.01	12.1	16.96	22.8	28.87
Water Speed (Ft./Second)	0.6	0.9	1.2	1.5	1.8	2.1	2.4
GPM Per Loop	0.18	0.27	0.36	0.45	0.54	0.63	0.72

*Shaded area indicates high head loss.

Thermal Track 200' Loops 20°F Temp. Drop

BTU/Sq. Ft.	10	15	20	25	30	35	40
Friction Loss (Ft. Head)	0.98	2.07	3.53	5.33	7.47	9.93	12.72
Water Speed (Ft./Second)	0.45	0.68	0.90	1.13	1.35	1.58	1.80
GPM Per Loop	0.14	0.20	0.27	0.34	0.41	0.47	0.54

Chart C-2 3/8" Zurn PEX Flow and Pressure Loss Data

Contractors Note: Be sure to follow all instructions elsewhere in this manual regarding protecting the panel from prolonged moisture contact. If these instructions are not followed, expansion of greater magnitude could create undesirable effects.

SPACING OF PANELS

The actual width of each panel is 15-7/8" which provides a built-in gap between panels for expansion at different temperatures.

OVERVIEW OF FLOOR SURFACE REQUIREMENTS

Note: See also the specific application drawings and notes for installing Thermal Track that follow in this manual.

Subfloor Requirements – General

The surface of the subfloor must be flat. The requirement for flatness is defined as the maximum difference between two adjacent high points and the intermediate low point. The maximum acceptable difference in level is 3/16 of an inch in a 10-foot radius.

Fill excessive voids or low areas using a leveling compound. Allow the leveling compound to dry thoroughly before beginning the installation. Check with the leveling compound manufacturer to be sure it is appropriate for the application. High areas can be ground down or floated over with a self-leveling compound.

The surface of the floor must be clean and dry.

OVERVIEW OF FLOOR SURFACE REQUIREMENTS, cont'd.

Subfloor Requirements – Wood Subfloors

Wood subfloors must have a stable moisture content between 6-10 percent.

Creaking subfloors must be repaired before installation. If the subfloor sags, inspect the joists below for twists or weakness. If the subfloor is cupped or uneven at the joints, recheck the moisture content of the subfloor to be sure it is in the 6-10 percent range. Check for excessive moisture in the crawl space or basement and look for other signs of a potential water problem.

High areas are sanded or planed, low areas patched or filled with an appropriate leveling compound, or covered with a rigid underlayment. When using a leveling compound, be sure to follow the manufacturer's recommendations, and allow the compound to dry completely before starting to install the floor.

Subfloor Requirements – Concrete Subfloors

See specific details that follow in the application section of this manual.

Installers Note: Thermal Track cuts easily with a quality circular saw blade. Pieces frequently must be cut to provide an accurate fit for each room. It is important that they be cut squarely to keep the alignment of grooves accurate in the installation. If you are installing large areas of Thermal Track you may wish to invest in a stand-up drill so that you do not have to bend over to set every screw when gluing and screwing Thermal Track to a subfloor. Cut short (6") pieces of Zurn PEX pipe. These can be used to align the grooves of the panels during installation by snapping them into the grooves with 3" in the groove on each panel. Once the panel is secured they must be removed prior to the installation of the pipe.

Equipment Required For Installation

The following is necessary for the installation of Thermal Track:

- Table or circular saw. A carbide blade is recommended.
- Electric or cordless drill gun with No. 2 Phillips bit and 5/8" drill bit for supply and return bury points.
- Rubber or hard hide mallet
- Chalk line, marking pencils and square.
- Vacuum cleaner to clean grooves.
- 6" pieces of 3/8" Zurn Pex tubing to align grooves.

Recommended Optional Items:

- Stand up drill
- Tubing uncoiler

LAYOUT AND INSTALLATION

Installation Step 1: Utilize a plan layout, determine panels needed (see material takeoff) and tubing lengths required. Be sure to always use good judgement in allowing enough tubing at ends for leaders up to manifolds. A plan should indicate which type of system will be implemented (see construction methods).

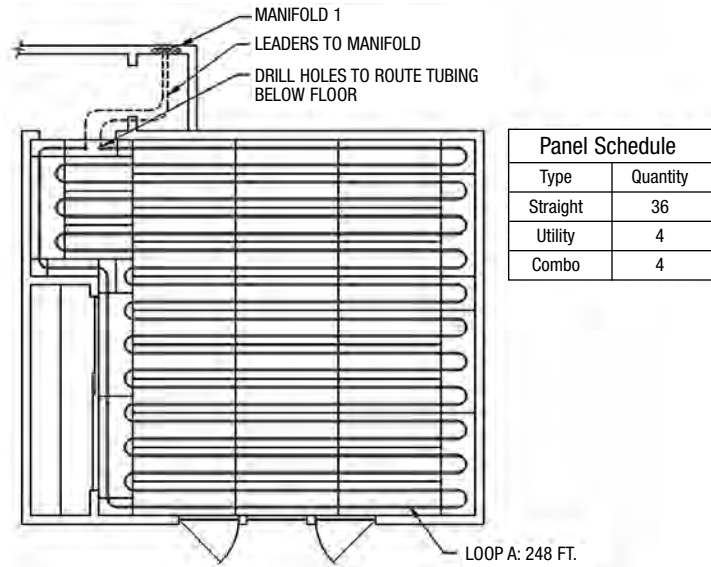

Installation Step 2: Begin the Thermal Track layout by starting at the beginning of the supply run into the space and running panels along the perimeter of the heated space to the area of highest heat loss.

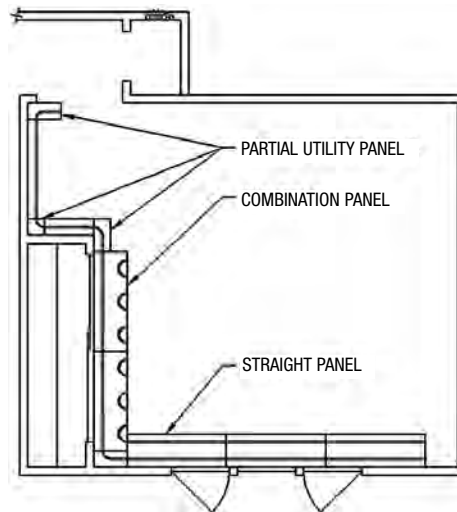

DETAIL SHOWING SPACING BETWEEN PANELS

This gap is “built-in” to standard panel dimensions (15-7/8" panel width).

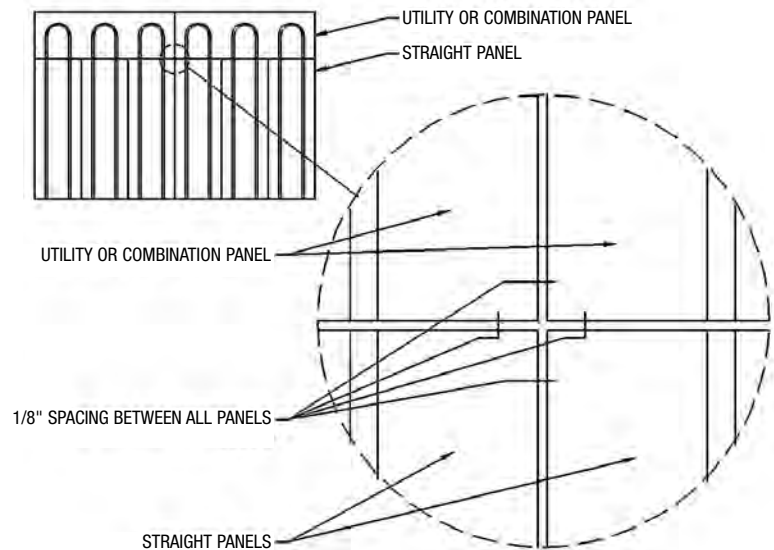

Installation Step 3: Add utility panels and straight panels working your way back away from the area of heat loss. Once all panels are in place, drill holes (subfloor with access application) or route leader back to manifold via custom grooves or grout (slab or existing subfloor application) for supply and return leaders to manifolds.

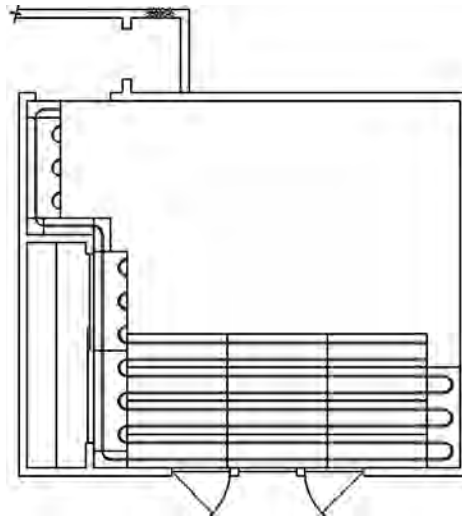

Installation Step 4: Feed supply tubing (enough to route to manifold) through drilled supply hole below the floor. Tubing may then be “popped” into grooves after all grooves have been thoroughly cleaned. Once tubing has been routed back to return hole, cut enough to route to return manifold.

Installers Note: Thermal Track has an aluminum Warmcoat™ metal layer that is slit for the grooves. It is designed to be folded down into the grooves and pressed to the side as the tubing is pushed into the groove. There is, intentionally, a tight tolerance between the 3/8" Zurn PEX tubing and the slightly undercut groove. This allows the tubing to be retained in the grooves once it is pushed in place. Usually, this only requires "walking the tubing into the groove." Occasionally tubing installation may require the use of a rubber or hide mallet to force the tubing in place in the grooves. After installing a loop of tubing, always walk the loop and make sure the tubing is fully in the groove for the entire length of the groove. This is very important! The top of the tubing should be just below the level of the top of the Thermal Track, and fully retained in the groove.

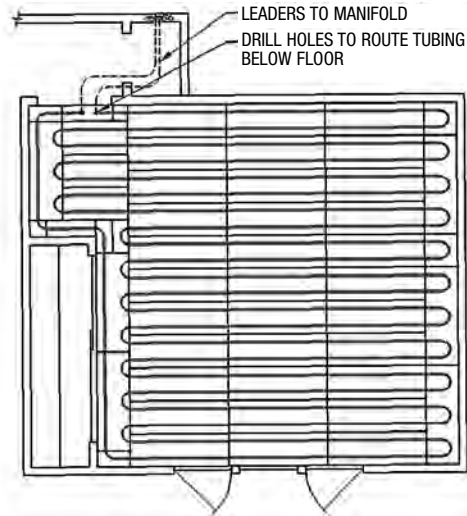

ADDITIONAL APPLICATION GUIDELINES

Special Coverage Areas

In areas of special coverage such as shower basins using tile grout as a base, tubing may be routed to and from Thermal Track in order to accommodate desired coverage.

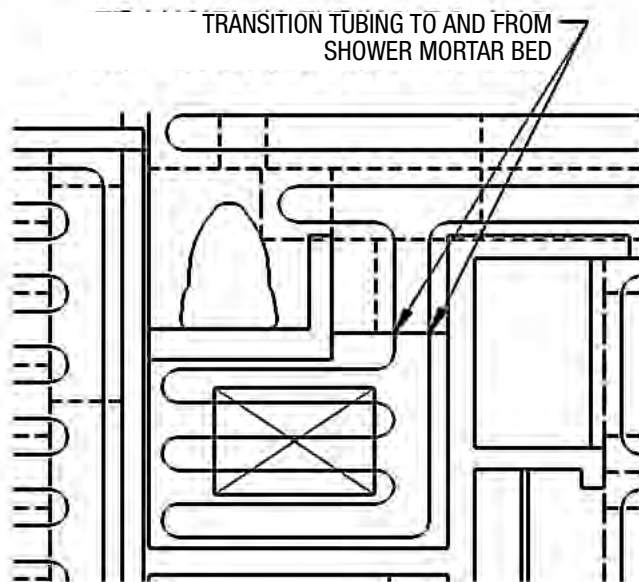

GLUING AND SCREWING PATTERNS

For full size pieces (16" x 48") ten screws should be used, eight on the perimeter as shown and two in the middle, or general 16" O.C. for the perimeter and 24" O.C. for the interior. Use construction adhesive type glue at minimum 1/8" bead in the gluing pattern shown on the bottom of all panels.

Installers Note: The glue may be applied to the under side of the panel or to the floor. Avoid getting glue in the groove or where it may come in contact with the tubing. Many glues can damage PEX tubing.

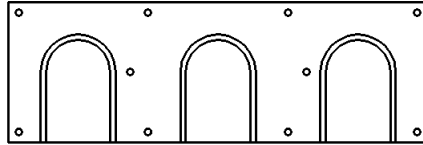

Utility Screwing Pattern

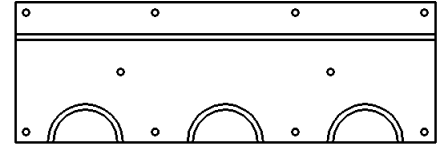

Combination Screwing Pattern

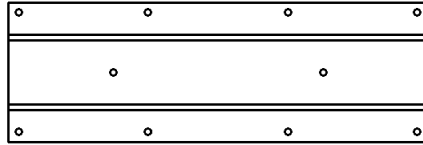

Straight Screwing Pattern

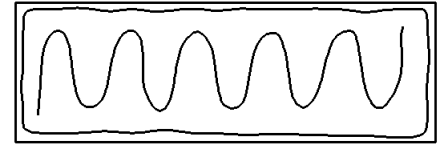

Gluing Pattern

ALTERNATIVE TO GLUING AND SCREWING

Gluing and Cross Stapling

As an alternative to gluing and screwing, Thermal Track may be installed by gluing and stapling as shown below. When installed with this method, it is very important that the panel is glued and stapled with at least as much glue and staple points as shown in the screwing pattern, and that the panels be cross stapled as shown for extra strength.

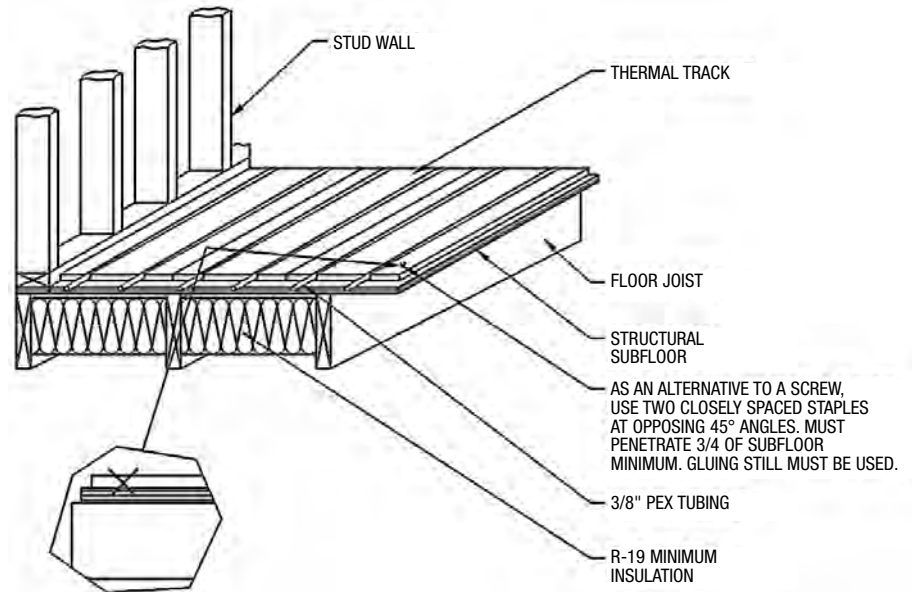

CONNECTIONS AT MANIFOLD

In situations where there are several loops from a single area running into one manifold and it is not possible to route tubing below subfloor, two methods may be used to run tubing to the manifold:

1. A solid MDF sheet may be placed next to the manifold in which supply and return lines are custom routed to the wall at the manifold.
2. Tubing may be run out of the Thermal Track, stapled to the subfloor and routed directly to the manifold. A grout may then be used to cover the tubing and leveled to the Thermal Track. If needed, sleepers are placed in between tubing to provide a nailing or screwing base for floor coverings. Use nailing plates as necessary to protect tubing from damage. Depending on how many circuits are on a given manifold, varying sizes of sheets or grouting area are required.

<u>No. of Circuits</u>	<u>Area or Sheet Required</u>
1-3	16" x 16"
4-6	32" x 32"
7-9	48" x 48"

APPLICATION – CARPET OVER SUBFLOOR

Carpet and pad may be installed over Thermal Track. When installing pad, care should be taken to avoid puncturing tubing. It is advised that a thin layer of underlayment plywood be applied over Thermal Track prior to carpet and pad installation to protect tubing from point loads. As with all radiant heating installations, a thin slab foam rubber pad and short, high-density carpet should be used. If carpet pad is glued, a high temperature latex adhesive must be applied. Glue to underlayment plywood; do not glue to Thermal Track or to tubing!

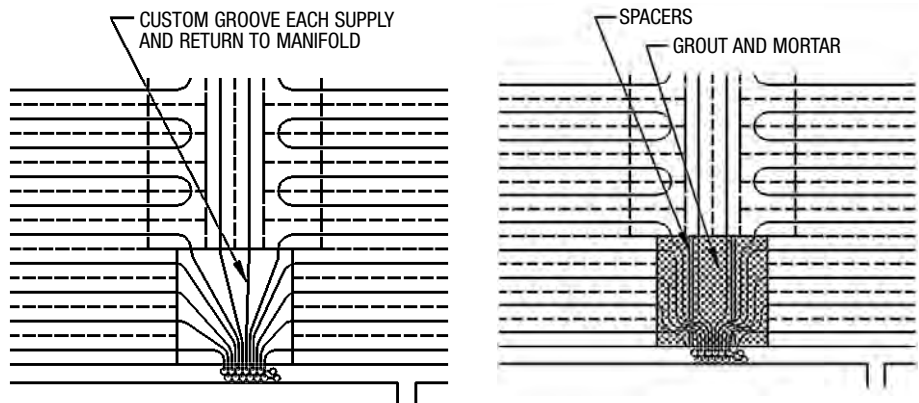

Installation

1. Thoroughly clean all surfaces that Thermal Track will be applied to. The surface to which Thermal Track will be attached must be flat and dry prior to installation.
2. Chalk lines of a square reference point, as construction of walls may be out of square.

APPLICATION – CARPET OVER SUBFLOOR, cont'd.

3. Lay out panels according to plan.
4. Be sure to use adequate adhesive.
5. Start layout of all pieces by securing a corner to allow for proper alignment.
6. Use groove alignment tool to ensure proper alignment of panels.
7. A 1/16" width space shall be used between panels.
8. Once all panels are installed, clean out all grooves with a vacuum.
9. Snap tubing into groove and route to manifold per plan.
10. Maintain 2" minimum tubing clearance from carpet tack strips.

Refer to the complete installation manual for further instructions on the installation of the Thermal Track system.

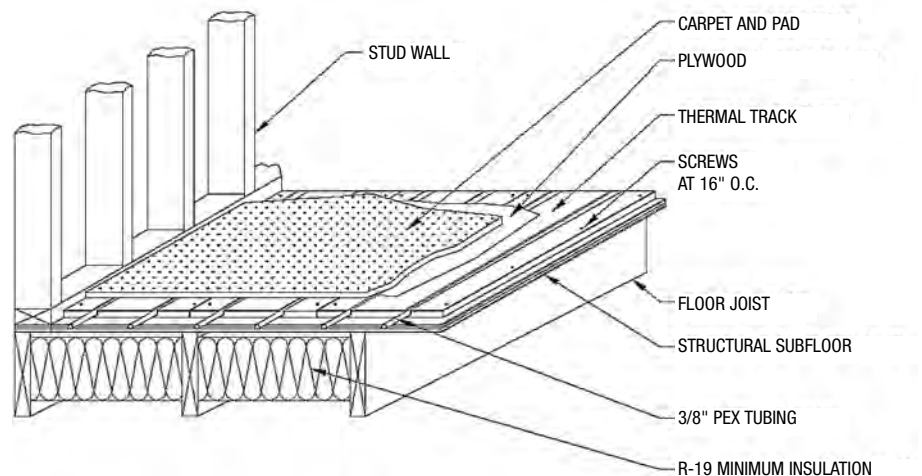

Figure A-5 Carpet Over Subfloor

APPLICATION – LAMINATE OR VINYL OVER SUBFLOOR

When installing vinyl flooring it is required, and when installing laminate flooring it is advised, that a thin layer of underlayment plywood be applied over Thermal Track. In wet locations, a sealant layer should be added as shown in details for wet locations tile/stone. Underlayment plywood that has a grid printed on it helps locate tubing runs and avoid puncturing tubing when the plywood is being screwed to the Thermal Track. In the case of vinyl, use underlayment, filler, and glues suggested by the manufacturer for use over radiant heat. Most vinyl flooring is manufactured to an ASTM standard with an upper limit of floor temperatures of 85°F. This should be followed. Many, but not all, laminate flooring products are suitable and recommended by the manufacturer for use with radiant floor heat. Check before installing. Many laminate flooring products have floor temperature limits that need to be observed as well.

APPLICATION – LAMINATE OR VINYL OVER SUBFLOOR, cont'd.

Installation

1. Thoroughly clean all surfaces that Thermal Track will be applied to. The surface to which Thermal Track will be attached must be flat and dry prior to installation.
2. Chalk lines of a square reference point, as construction of walls may be out of square.
3. Lay out panels according to plan.
4. Be sure to use adequate adhesive.
5. Start layout of all pieces by securing a corner to allow for proper alignment.
6. Use groove alignment tool to ensure proper alignment of panels.
7. A 1/16" width space shall be used between panels.
8. Once all panels are installed, clean out all grooves with a vacuum.
9. Snap tubing into groove and route to manifold per plan.
10. Attach underlayment, if required, with care not to puncture tubing.
11. Install laminate flooring crosswise to Thermal Track whenever possible.

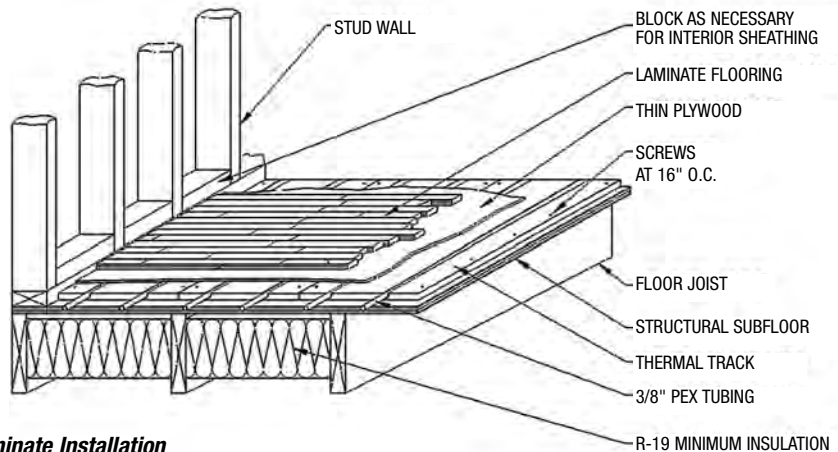

Laminate Installation

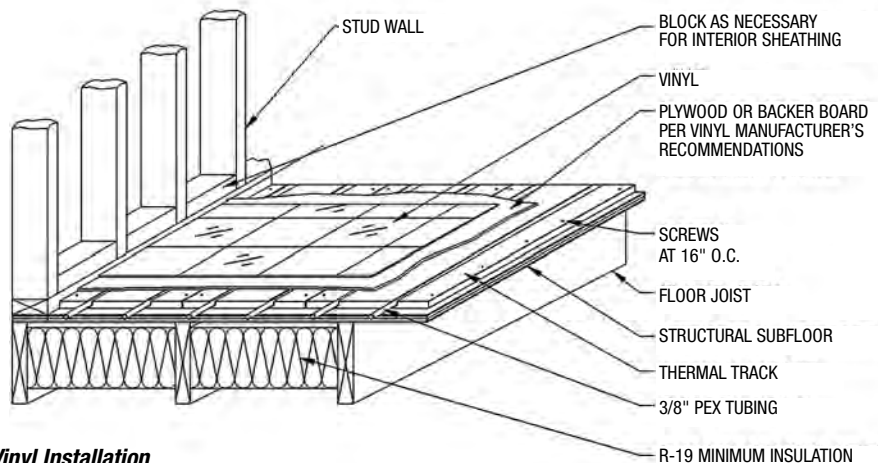

Vinyl Installation

APPLICATION OPTIONS – WOOD FLOORS OVER THERMAL TRACK

Thermal Track may be used under wood flooring in several ways:

1. Conventional nailed and hardwood type system may be used directly over Thermal Track with nailing long enough to penetrate subfloor as described in the following section. When wood flooring systems are installed directly over Thermal Track, the hydronic heating system should employ controls that gradually adjust water temperature going to the Thermal Track with a reset curve. See details of this method on following pages.
2. Optionally, two layers of 1/2 inch plywood may be floated on top of the Thermal Track and strip flooring nailed to it (as shown on the following page) in a method recommended by the National Wood Flooring Association. This method has the advantage that it allows the wood flooring system to float independently from the Thermal Track, but has significant disadvantages in that the extra one inch thickness of wood limits the output of the system. For example, two layers of 1/2" plywood with 3/4" of strip oak flooring has an R-Value of about R-2.3. This limits the output of the floor at 150°F water temperature to about 26 BTU/square foot. A careful heat loss analysis must be done to see if this method will produce enough heat. If not, another method should be chosen or provisions made for backup heat. A hydronic control strategy that gradually adjusts water temperature going to the Thermal Track with a reset curve is recommended but not required.
3. Clip style floating strip flooring systems must be installed directly over Thermal Track such that clips will never come in contact with tubing.
4. The preferred wood flooring over any radiant heating system is to use a floating wood floor with a specific warranty for use over radiant floors. Many manufacturers of these products have such a warranty as well as having extensive experience both in Europe and North America with radiant heating applications. Edge glued floating engineered wood flooring systems are preferred since they are dimensionally stable, and expand independently from any thermal mass. Thermal Track should be installed such that the hardwood runs perpendicular to the majority of the tubing runs.
5. Glued down wood flooring systems are not recommended unless a layer of plywood is first screwed down to the Thermal Track and the wood is attached to the plywood according to the flooring manufacturers recommendations for installation over radiant heat.

APPLICATION OPTIONS – WOOD FLOORS OVER THERMAL TRACK, cont'd.

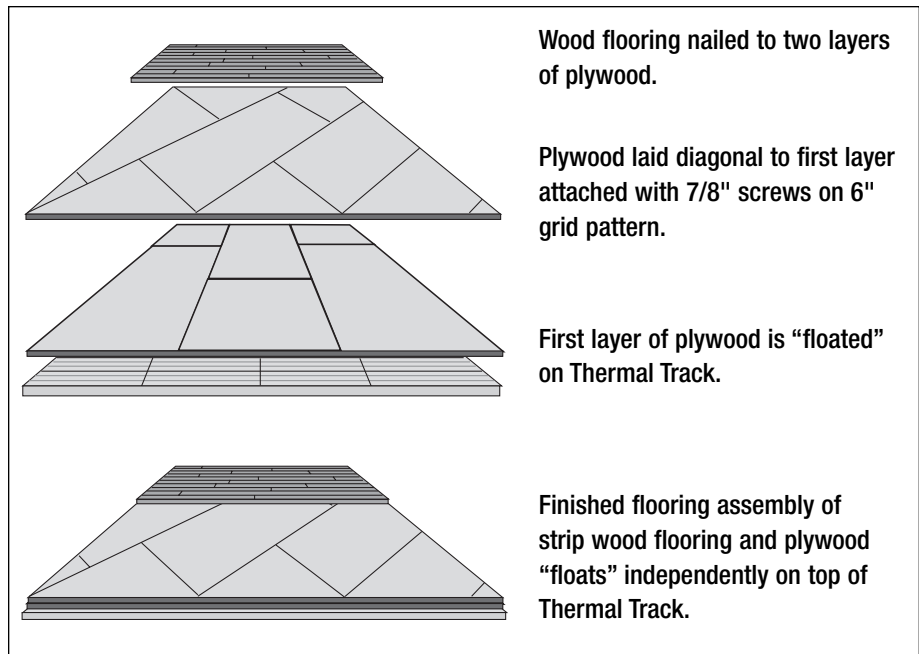

NWFA Double Plywood Floating Method

APPLICATION – HARDWOODS OVER SUBFLOOR

Conventional nailed and hardwood type system may be used directly over Thermal Track with nailing long enough to penetrate subfloor.

Installation

1. Thoroughly clean all surfaces that Thermal Track will be applied to.
2. Chalk lines of a square reference point as construction of walls may be inconsistent.
3. Lay out panels according to plan.
4. Be sure to use adequate adhesive.
5. Start layout of all pieces by securing a corner to allow for proper alignment.
6. Use groove alignment tool to ensure proper alignment of panels.
7. A 1/16" width space shall be used between panels.
8. Once all panels are installed, clean out all grooves with a vacuum.
9. Snap tubing into groove and route to manifold per plan.
10. Care should be taken to avoid nailing tubing.
11. Do not end hardwood floor joint at Thermal Track joint.
12. Hardwood floor nails should be long enough to penetrate both hardwood and subfloor.
13. Employ controls that gradually adjust water temperature going to the Thermal Track with a reset curve.

APPLICATION – HARDWOODS OVER SUBFLOOR, cont'd.

14. It is extremely important that the designer knows which way it is desired that the strip flooring be aligned prior to the design of the Thermal Track system since the direction of the Thermal Track should run perpendicular to the direction of the strip flooring.
15. Install strip flooring with mallet driven nails and nails penetrating the Thermal Track 1/2" into the subfloor.
16. Use 15-gauge nails (2.5" with 3/4" floors) to penetrate subfloor.
17. A nailer such as the Senco No. SFM40 with tongue and groove attachment No. SFM40 TG should be used.
18. Keep structure humidity within the range specified by the manufacturer.
19. Install the wood at the relative humidity recommended by the manufacturer for the climate involved.
20. Use narrower 2"-3 1/2" strips over radiant floors.
21. The lessons of local practice and climate should be referenced.
22. Make sure the heating system has been running and the space has been maintained at least 65°F long enough that temperature and humidity have stabilized to predicted future levels.
23. Let the product acclimatize before installation.

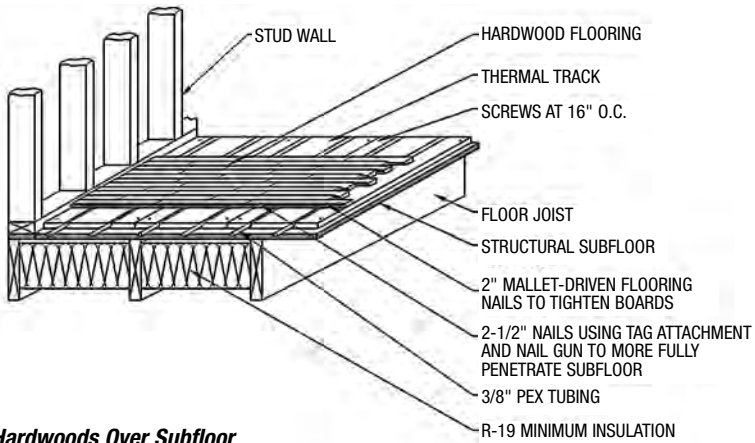

CONSIDERATIONS WITH TRADITIONAL WOOD FLOORING OVER THERMAL TRACK

The key to installing wood floors over radiant heat is to give extra care to wood species, wood width and thickness, moisture levels, installation practices, the heat output requirements of your system, and radiant heating control.

Panel Width: Install narrow panel widths, preferably 3 inches or less. Avoid panels wider than 4 inches. Narrow panels provide more gaps for expansion and contraction across a floor; therefore, gaps resulting from natural movement are much less noticeable. The maximum recommended panel depth is 3/4 inch. Thicker panels add too much resistance to heat transfer.

Dimensional Stability: Use quarter sawn wood. It's significantly more dimensionally stable than wood that is plain sawn. Pick a wood that's known for its dimensional stability. American cherry, ash, most softwoods, and teak fill this bill, and oak is reasonably stable. By contrast, hickory, maple, madronne, and American beech are known as less stable.

Age and Drying in Tropical Woods: If you're importing tropical or exotic woods, pay close attention to the source, age, and how the wood has been dried. Tropical wood needs to dry slowly. Quick drying creates stresses that can affect the wood later as it expands and contracts. If your supplier has stored the wood in your region with no problems for one to two years, surprise stress-related problems are much less likely. Though it can be fun to be unique, avoid pioneering the use of a wood where there is little information on its dimensional stability.

Moisture: Wood naturally expands and contracts in response to changes in moisture. With this in mind, avoid installing wood flooring during stages like sheet rocking or painting, when significant moisture may be introduced into a structure. Operate the heating system until the humidity in the structure stabilizes to the average level expected for the area in which the wood floor will be installed. Then, allow the wood to acclimatize to this humidity level by "sticking" (usually several weeks) before installation. This will minimize dimensional changes due to moisture. Make sure the wood is dry, since radiant heat itself can be drying. Experienced flooring installers recommend buying wood for radiant at around 6 to 8 percent moisture content. This figure may change some regionally. Use a moisture meter during the construction process, and then use the average of many readings. Remember, the average expected humidity level of a structure is an average of seasonal conditions. So if the structure is expected to average 30 percent humidity in the winter and 50 percent in the summer, the average would be 40 percent. This equates to about a 7.5 percent moisture content in the wood. Most installers consider this average the ideal moisture level at which to install wood flooring. These numbers can vary significantly by region.

Surface Temperature: The maximum surface temperature of a wood floor should be limited to 85°F. Use a control strategy that assures this will not be exceeded and brings the floors through temperature changes gradually.

CONSIDERATIONS WITH TRADITIONAL WOOD FLOORING OVER THERMAL TRACK, cont'd.

Humidity Control: In climates with large humidity variations, install humidity control. In vacation cottages with intermittent use, consider back sealing panels before installation to make them more stable to changes in moisture in the structure.

APPLICATION – TILE OR STONE OVER SUBFLOOR

For masonry tile and stone it is recommended that backer board be used over Thermal Track. Conventional mortar bed or thin set installation may then be used. In kitchen, baths, laundry, or any other area where water may be present, water sealant (Nobleseal) shall be used. Where tile is going to be thin-set, anti-fracture membrane (Nobleseal) shall be used.

Installation

1. Thoroughly clean and level all surfaces that Thermal Track will be applied to.
2. Chalk lines of a square reference point as construction of walls may be inconsistent.
3. Lay out panels according to plan.
4. Be sure to use adequate adhesive.
5. Start layout of all pieces by securing a corner to allow for proper alignment.
6. Use groove alignment tool to ensure proper alignment of panels.
7. A 1/16" width space shall be used between panels.
8. Once all panels are installed, clean out all grooves with a vacuum.
9. Snap tubing into groove and route to manifold per plan.
10. Maintain 2" minimum tubing clearance when screwing backer board down.

Refer to the complete installation manual for further instructions on the installation of the Thermal Track system.

Installers Note: Do not omit the backerboard layer. Do not thinset directly to Thermal Track, the aluminum will not provide a good bond. Do not install crack isolation membranes directly to Thermal Track, they will not get a good bond and many of them use materials that are incompatible for contact with PEX pipe.

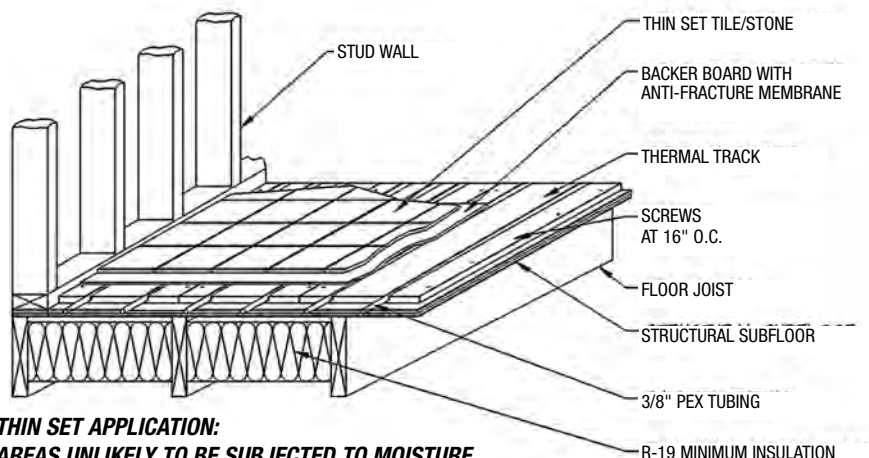

**THIN SET APPLICATION:
AREAS UNLIKELY TO BE SUBJECTED TO MOISTURE**

Note on Sealing Thermal Track:

The aluminum layer on the top of each Thermal Track is highly water resistant. This means that a significant degree of moisture protection can be given to the panel simply by using silicon sealant as a caulk between the panels. Properly applied, this will profoundly reduce the likelihood of water transmission into the panels. This is not a substitute for recommended installation methods in wet areas.

TILE AND STONE: MORE DETAILS

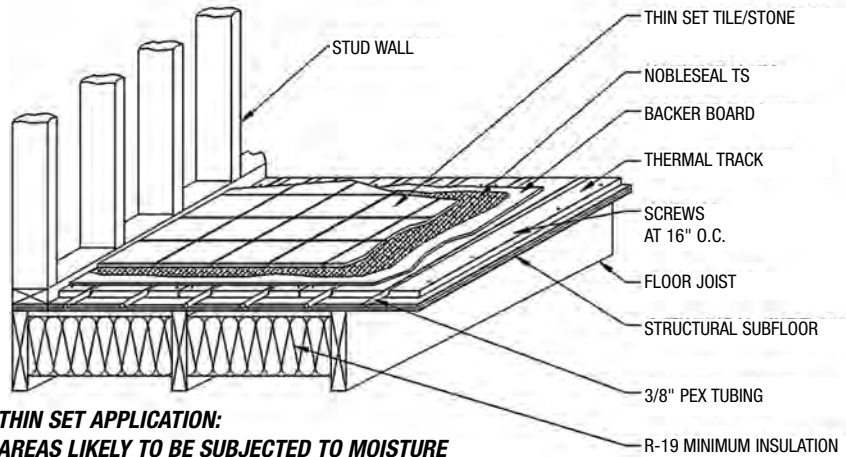

***THIN SET APPLICATION:
AREAS LIKELY TO BE SUBJECTED TO MOISTURE***

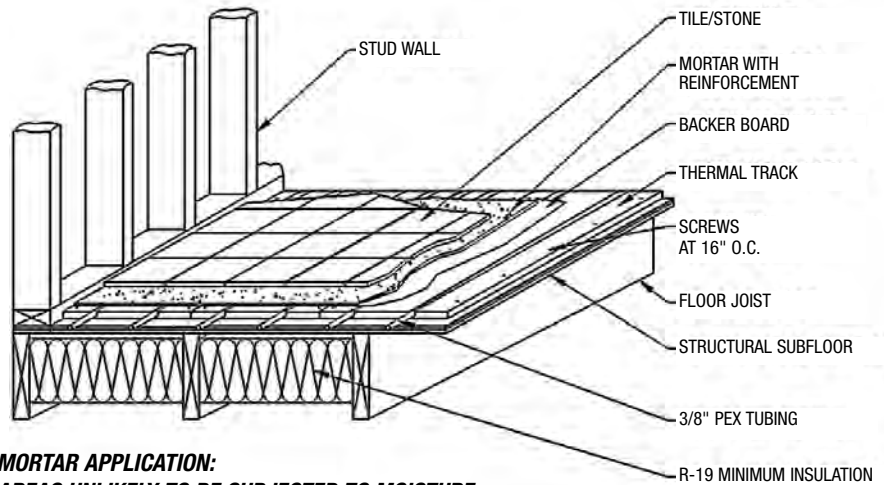

***MORTAR APPLICATION:
AREAS UNLIKELY TO BE SUBJECTED TO MOISTURE***

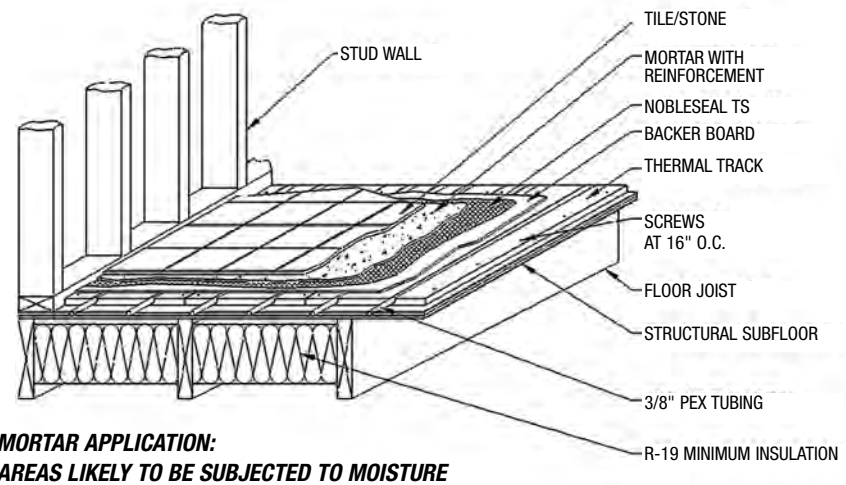

***MORTAR APPLICATION:
AREAS LIKELY TO BE SUBJECTED TO MOISTURE***

APPLICATION – OVER SLAB

Concrete Requirements

While successful installations of Thermal Track over concrete have been done it is not a preferred application due to the difficulties of sealing concrete and attaching Thermal Track to concrete. Thermal Track may be installed over concrete using the following method only when the installing parties are willing to assume full responsibility for the installation and all issues regarding moisture and attachment of Thermal Track to concrete. All concrete slabs give off supplementary moisture whether above, on, or below grade. This can cause problems for any board product installed over it, including Thermal Track. **It is strongly recommended that all slabs below grade and slabs on grade be sealed against moisture penetration before installing Thermal Track.** A product such as Hydroment Ultraseal may be used. Remember that while a slab may appear to be or be dry during one time of year, this may change as environmental conditions change. Below is a procedure for testing moisture of above grade slabs such as between floors in commercial construction. When in doubt seal the slab before proceeding with the installation.

Initially, check the moisture by taping a 2 ft. x 2-ft. piece of polyethylene film in at least 2 or 3 locations (more in large areas). A rubber-backed mat can be used instead of the polyethylene film. Indications of a high moisture content include darker or discolored concrete, cloudy polyethylene film or condensation on the underside of the film. A moisture meter may be used, but it can only be used as an indicator because different additives in concrete can cause misleading results. If there are any indications of a high moisture content, use a test method that will determine the exact moisture content of the slab based on its dry weight, or use a calcium chloride test. When using the 6 mil polyethylene vapor barrier, the moisture content must not exceed 2.5% on a dry weight basis. With a calcium chloride test, the maximum acceptable reading is 5 lbs./4 hours/1,000 sq. ft. New concrete slabs and basements must be cured for a minimum of 60 days prior to installation. Remember, it is recommended that all slabs be sealed against moisture penetration before installing Thermal Track.

After first determining that the existing or new slab is sufficiently dry, and then sealing the slab, you may proceed with the Thermal Track installation.

For masonry tile, stone and vinyl flooring, it is recommended that backer board be used over Thermal Track. Conventional mortar bed or thin set installation may then be used. Use of vinyl floors and associated adhesives and materials should be checked for temperature limitations. Conventional and floating type wood floor systems may be used directly over Thermal Track. Floating laminated wood floors are preferred. Traditional strip wood floors require that 3/4" T&G plywood is first glued to the slab. Tubing is visible so hardwood may be directly nailed to Thermal Track. See additional notes on installing wood floors elsewhere in this manual. Thermal Track should be installed such that the hardwood runs perpendicular to the majority of the tubing runs.

Carpet and pad may be installed as normal over Thermal Track. Carpet pad should avoid being stapled due to tubing being obscured. In cases where extreme weight loads are anticipated, it is advised that backer board be applied over Thermal Track prior to carpet and pad installation. As with all radiant heating installations, a thin conductive foam rubber pad and short, high density carpet should be used.

APPLICATION OVER SLAB

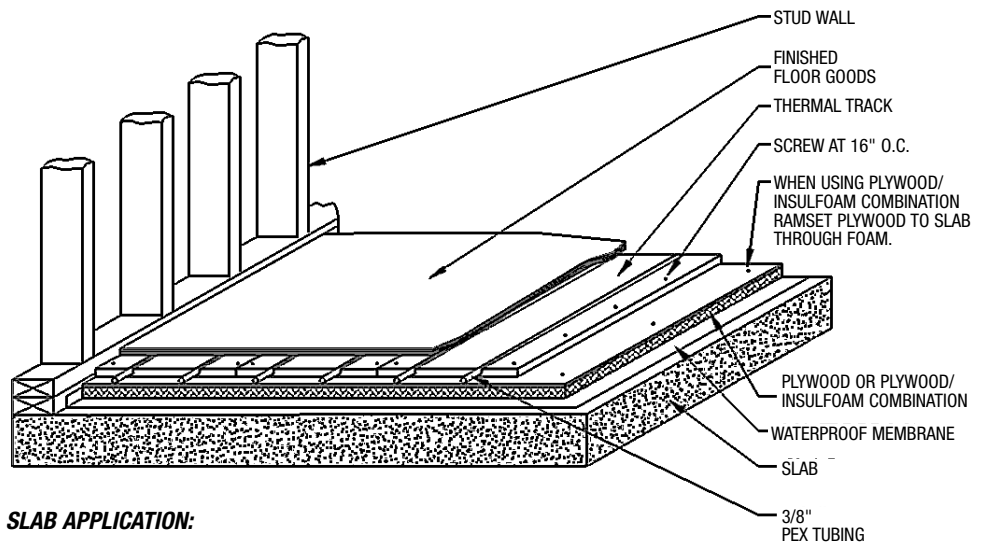

SLAB APPLICATION:

Installation Over Concrete

1. Thoroughly clean and level all surfaces that Thermal Track will be applied to.
2. Seal concrete with vapor membrane such as Hydroment Ultraseal per manufacturer's guidelines.
3. Glue T&G 3/4" plywood down to vapor membrane. Be sure to use adequate adhesive compatible with vapor membrane to glue down the plywood to the membrane. Weight the plywood if necessary to make it lie flat.
Insulfoam/plywood combination may be used instead of plywood alone provided the plywood layer is at least 5/8" thick (3/4" preferred), and the foam can be bonded with a compatible adhesive to the vapor membrane.
4. Chalk lines of a square reference point as construction of walls may be inconsistent.
5. Lay out panels according to plan.
6. Glue and screw or staple Thermal Track to plywood. Be sure to use adequate adhesive.
7. Start layout of all pieces by securing a corner to allow for proper alignment.
8. Snap a 6" long piece of tubing into the groove to ensure proper alignment of panels.
9. Once all panels are installed, clean out all grooves with a vacuum.
10. Snap tubing into groove and route to manifold per plan.
11. Follow the installation instructions on the previous pages for the type of finish flooring that you are installing over the Thermal Track.

APPLICATION OF THERMAL TRACK® TO WALLS OR CEILING

Thermal Track® may be installed on walls or ceilings as extra heat output areas when the floors cannot provide all the necessary heat. Radiant walls and ceilings may also be used to provide all the heat of a room in certain circumstances when properly designed. The heat output of radiant walls and ceilings is different from floors, due to differences in the strength of the convective component of the heat which is stronger in radiant floor heating than in walls or ceilings. However, since walls and ceilings are typically covered only with the relatively low r-value of 1/2" of sheet rock, and acceptable surface temperatures are higher, the heat output of these systems can be quite substantial. It is very important not to overheat sheetrock or discoloration or damage may occur. For design purposes, use chart C-1 but correct the output in BTU's downward 5% for walls and 10% for ceilings. This is because the convective component of the heat output is lower in wall and ceiling radiant heating systems.

Thermal Track® wall and ceiling systems shall be installed as follows:

Thermal Track® shall be installed square to framing, screwed to studs, rafters and/or blocking with as many joints as possible screwed securely to the framing. Thermal Track® shall be secured to framing on both sides of the grooves on every board. Layout of all pieces shall be started by securing a corner to allow for proper alignment. 6" lengths of tubing shall be temporarily placed in the grooves lapping 3" into each board to help align the grooves of the boards during installation. Once all boards are installed, all grooves shall be cleaned out with a vacuum just prior to tubing installation. Tubing shall be snapped into the groove and routed to manifold per the plan. A 1" minimum tubing clearance from tubing shall be maintained for all nailing. Add steel plate protectors over tubing where tubing crosses studs. Water temperatures shall not exceed 120F° supply water temperatures when Thermal Track® is installed under plaster or sheetrock.

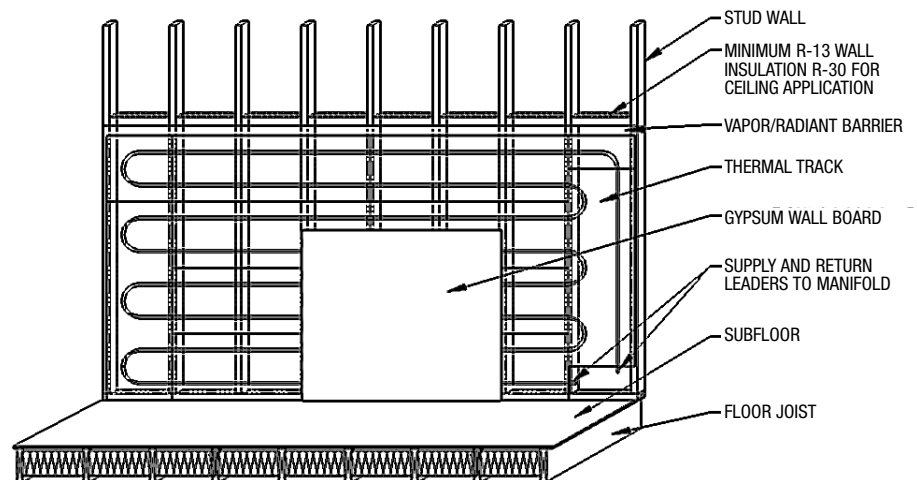

CAUTIONS AND LIMITATIONS OF USE:

General Caution:

As with any radiant heating system, do not install Thermal Track® without an accurate room-by-room heat loss analysis for the structure to be heated, as well as a design/layout for Thermal Track® that takes into account the resistance and heat transfer of the actual floor coverings. If Thermal Track® cannot provide all the necessary heat, make provisions for additional backup heat

Installer Caution:

This manual is deemed to be current at the time of publication. It is the installer's responsibility to install according to the most current Application Guide. This guide does not purport to address all relevant issues; it assumes a knowledge of good practice in both hydronics and construction methods. Installers should always consult all relevant local, regional and national codes, and adhere to good construction practice. Thermal Track® should only be installed by knowledgeable, qualified installers. Thermal Track® installations frequently require the coordination of trades. These are, most typically, mechanical and flooring trades. Any issues regarding this coordination should be worked out in advance. Failure to follow the instructions of this guide, failure to adhere to relevant local, regional and national codes, failure to coordinate trades, and failure to follow good construction practice may cause an unsatisfactory result. See also "limitations of use" elsewhere in this publication. The limitations and instructions of use for PEX pipe and all other hydronic components provided by the manufacturers must also be referenced and followed during installation; this manual does not address many aspects of a hydronic installation.

Limitations of Use:

Thermal Track® is designed for interior use only, and is to be installed only on dry substrata once a structure is closed in, protected from the environment, and will remain dry. Thermal Track® is not intended as, or rated as, a replacement or substitution for a structural subfloor. The BTU output of Thermal Track® is limited by the R-values of the finish goods applied over it and by the recommended and available water temperatures. Thermal Track® is not intended for use with finish goods that are incompatible with the temperatures and conditions present in a radiant heating system. Thermal Track® is not intended as a finish floor, and should be left uncovered and unprotected only during installation.

TYPICAL R-VALUES OF FLOORING GOODS AND MATERIALS

Material	Typical R-Value	R-Value Per Inch	Typical Thickness
Plywood	0.825	1.10	0.750
Plywood Underlayment (1/4")	0.275	1.10	0.250
Softwood	0.825	1.10	0.750
Sheet Vinyl	0.200	1.60	0.125
Vinyl Composition Tile (VCT)	0.200	1.60	0.125
Linoleum	0.400	1.60	0.250
Linoleum	0.200	1.60	0.125
Dense Rubber Flooring	0.250	1.30	0.325
Recycled Rubber Flooring	1.100	2.20	0.500
Cork	1.125	3.00	0.375
Cork/MDF/Laminate	1.175	2.35	0.500
Brick	3.375	2.25	1.500
Marble	0.400	0.80	0.500
Ceramic Tile	0.250	1.00	0.250
Thinset Mortar	0.050	0.40	0.125
MDF/Plastic Laminate	0.500	1.00	0.500
Laminate Floor Pad	0.300	1.92	0.160
Engineered Wood	0.250	1.00	0.250
Engineered Wood	0.375	1.00	0.375
Engineered Wood	0.625	1.00	0.625
Engineered Wood	0.750	1.00	0.750
Engineered Wood Flooring Pad	0.200	1.60	0.125
Engineered Bamboo	0.720	0.96	0.750
Oak	0.638	0.85	0.750
Ash	0.750	1.00	0.750
Maple	0.750	1.00	0.750
Pine	0.975	1.30	0.750
Fir	0.900	1.20	0.750
Carpet Pad/Slab Rubber 33lb	0.320	1.28	0.250
Carpet Pad/Slab Rubber 33lb	0.480	1.28	0.375
Carpet Pad/Slab Rubber 33lb	0.640	1.28	0.500
Carpet Pad/ Waffle Rubber 25lb	0.620	2.48	0.250
Carpet Pad/Waffle Rubber 25lb	1.240	2.48	0.500
Hair Jute	1.940	3.88	0.500
Hair Jute	1.250	3.88	0.325
Prime Urethane	1.400	4.30	0.325
Prime Urethane	2.150	4.30	0.500
Bonded Urethane	1.350	4.20	0.325
Bonded Urethane	2.100	4.20	0.500
Carpet	0.700	2.80	0.250
Carpet	1.050	2.80	0.375
Carpet	1.400	2.80	0.500
Carpet	1.750	2.80	0.625
Carpet	2.100	2.80	0.750
Wool Carpet	1.575	4.20	0.375
Wool Carpet	2.100	4.20	0.500



ZURN INDUSTRIES, LLC
RADIANT HEATING SYSTEMS
1801 PITTSBURGH AVENUE
ERIE, PA 16502
PHONE: 1-800-872-7277
FAX: 1-800-209-2148
www.zurn.com

In Canada:

ZURN INDUSTRIES LIMITED
3544 NASHUA DRIVE
MISSISSAUGA, ONTARIO CANADA L4V 1L2
PHONE: 905/405-8272
FAX: 905/405-1292

Form No. ZMKTG370-07, 5/12