



# SINK FAUCET Z842G1-XL-15F

TAG \_\_\_\_\_



### Engineering Specifications: Zurn AquaSpec® Z842G1-XL-15F

Polished chrome-plated cast brass 8" [203mm] sink faucet with quarter turn ceramic disc cartridges, 3/8" [10mm] short swivel inlets providing adjustable centers from 7-1/4" [184mm] to 8-3/4" [222mm] and a 8" [203mm] cast brass swing spout with a full flow outlet. Unit is furnished with 2-1/2" [64mm] vandal-resistant color-coded metal lever handles.

Zurn Lead Compliant\* "XL" products are a line of durable, high quality brass faucets and fixtures that are designed and manufactured to comply with state laws and local codes that mandate lead content levels. Zurn "XL" products are manufactured with \*not more than 0.25% lead content when used with respect to wetted surfaces of pipes and pipe fittings, plumbing fitting and fixtures: California Health & Safety Code § 116875; Vermont 9 VCA § 2470h.

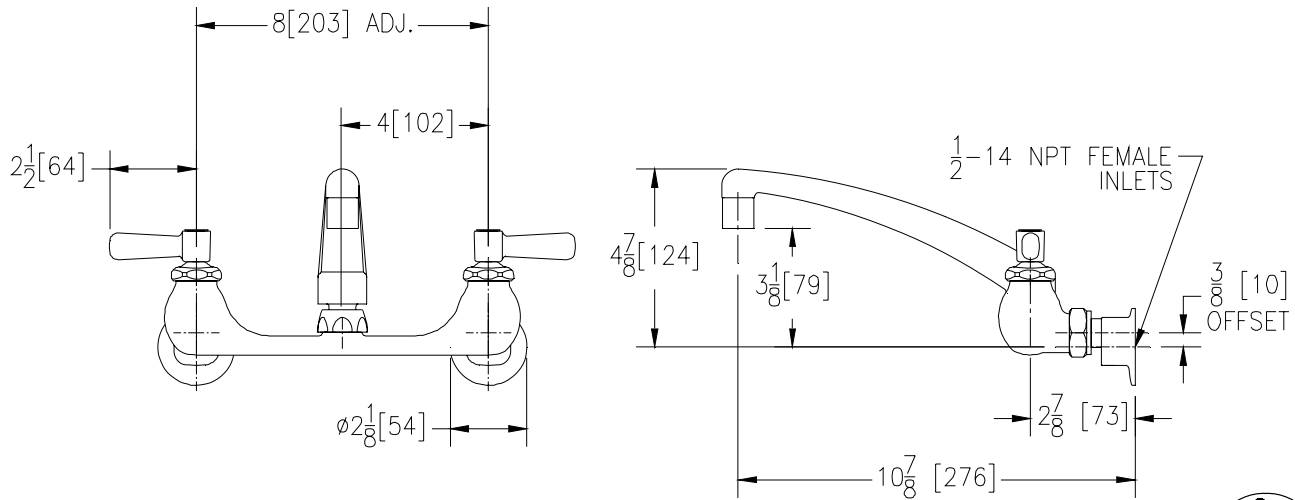

Note: All dimensions are for reference only. Do not use for pre-plumbing



### OPTIONAL ACCESSORIES

Suffix	Description
___ -HCT	Hot/Cold Text Indexes
___ -LSI	2-1/2" [64mm] Long Swivel Inlets with Integral Stops
___ -1F	2.2 GPM [8.3 L] Pressure Compensating Female Aerator
___ -2F	2.2 GPM [8.3 L] Vandal-Resistant Pressure Compensating Female Aerator
___ -3F	0.5 GPM [1.9 L] Vandal-Resistant Pressure Compensating Female Spray Outlet
___ -4F	2.2 GPM [8.3 L] Vandal-Resistant Pressure Compensating Female Laminar Flow Outlet
___ -7F	1.0 GPM [3.8 L] Pressure Compensating Female Spray Outlet
___ -16F	1.0 GPM [3.8 L] Vandal-Resistant Pressure Compensating Female Spray Outlet
___ -17F	1.5 GPM [5.7 L] Vandal-Resistant Pressure Compensating Female Aerator
___ -18F	1.5 GPM [5.7 L] Vandal-Resistant Female Pressure Compensating Laminar Flow
___ -19F	1.5 GPM [5.7 L] Anti-Microbial Pressure Compensating Female Laminar Flow Outlet
___ -21F	1.0 GPM [3.8 L] Pressure Compensating Female Laminar Flow Outlet
___ -22F	1.0 GPM [3.8 L] Vandal-Resistant Pressure Compensating Female Laminar Flow Outlet
___ -23F	1.5 GPM [5.7 L] Pressure Compensating Female Aerator

ZURN INDUSTRIES, LLC ♦ COMMERCIAL BRASS OPERATION ♦ 2640 SOUTH WORK STREET ♦ FALCONER NY 14733

Phone: 1-800-997-3876 ♦ Fax: 1-919-775-3541 ♦ www.zurn.com

In Canada: ZURN INDUSTRIES LIMITED ♦ 3544 Nashua Drive ♦ Mississauga, Ontario L4V1L2 ♦ Phone: 905/405-8272 Fax: 905/405-1292