

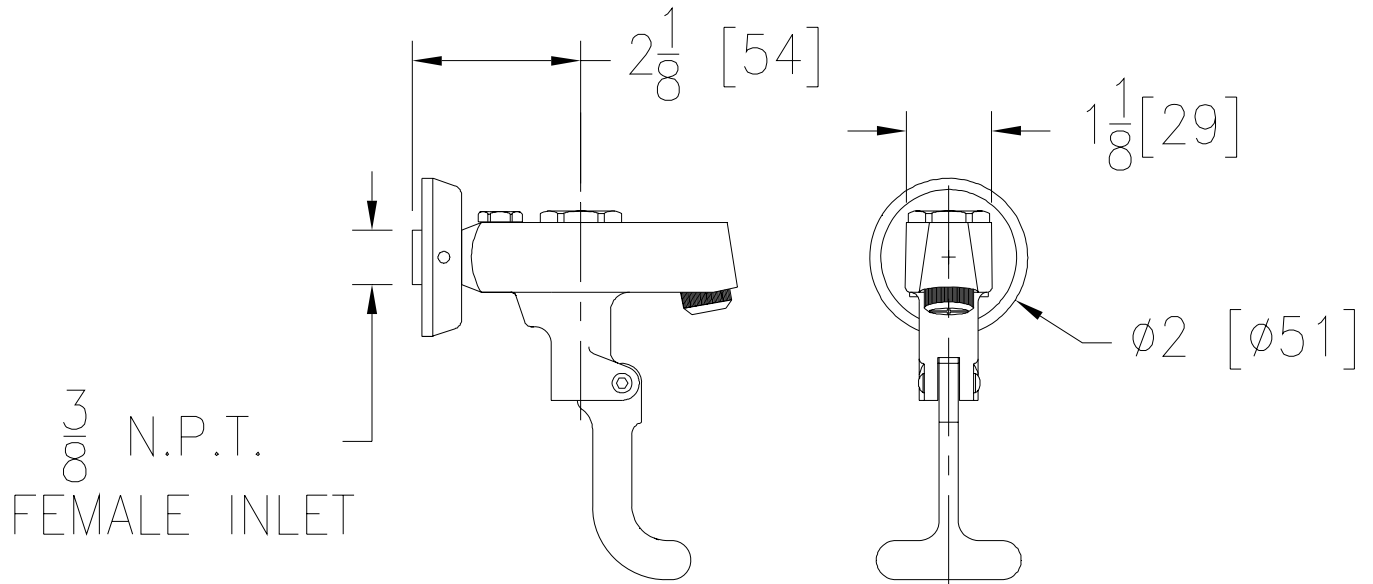

GLASS FILLER
Z83500-WM
TAG _____



Engineering Specification: Zurn AquaSpec® Z83500-WM
Polished chrome wall mounted glass filler. Unit furnished with a 3/8" N.P.T. female inlet, adjustable escutcheon, volume regulator and a Lexan push-back arm.



Note: All dimensions are for reference only. Do not use for pre-plumbing.

OPTIONAL ACCESSORIES

No options required

ZURN INDUSTRIES, INC. ♦ COMMERCIAL BRASS OPERATION ♦ 2640 SOUTH WORK STREET ♦ FALCONER NY 14733

Phone: 1-716-665-1132 ♦ Fax: 1-716-665-1135 ♦ World Wide Web: www.zurn.com

In Canada: ZURN INDUSTRIES LIMITED ♦ 3544 Nashua Drive ♦ Mississauga, Ontario L4V1L2 ♦ Phone: 905/405-8272 Fax: 905/405-1292