

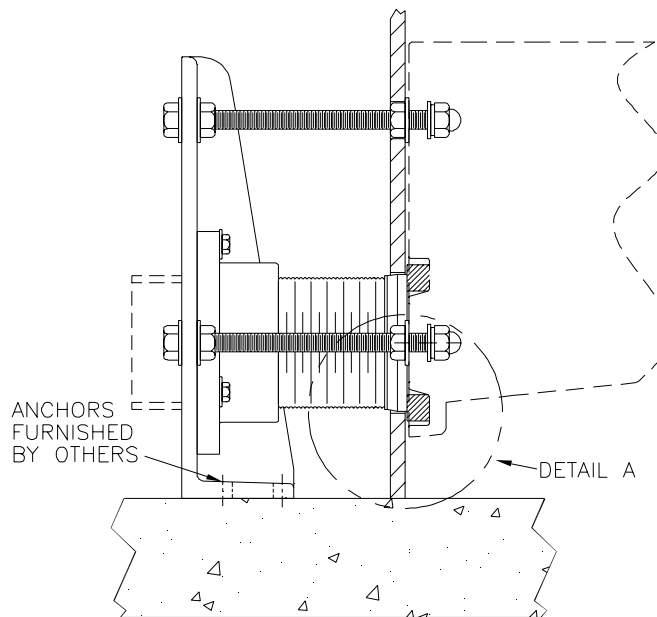

# Z1212 INSTALLATION INSTRUCTIONS

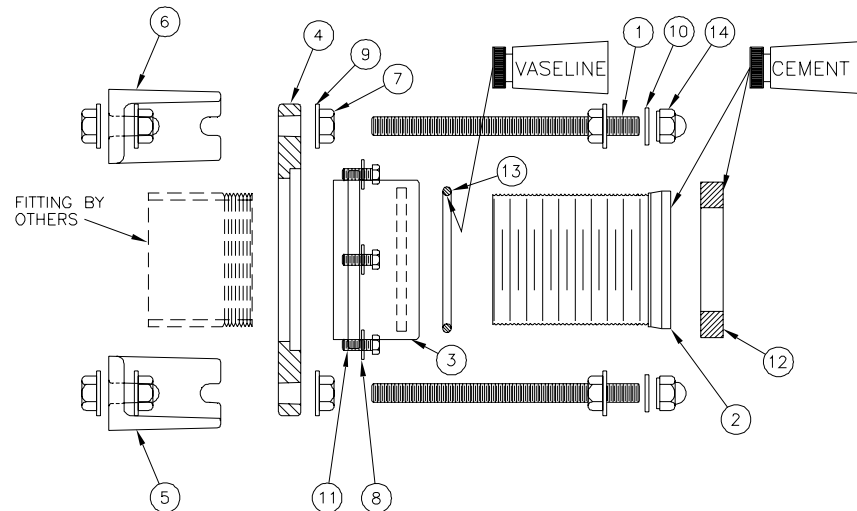

ITEM NO.	QTY.	DESCRIPTION	PART NUMBER
1	4	5/8 X 9 STUD	14861-075
2	1	COUPLING	18743-058
3	1	NOSE PIECE	28732-004
4	1	FLANGE	53743-001
5	1	LH UPRIGHT	53750-001
6	1	RH UPRIGHT	53750-002
7	12	5/8 JAM NUTS	14850-008
8	3	3/8 WASHERS	14858-003
9	12	5/8 WASHERS	14858-007
10	4	5/8 FIBER WASH.	23444-009
11	3	3/8 X 1" HHCS	26050-043
12	1	GASKET	32844-001
13	1	O-RING	50369-001
14	4	5/8 CAP NUT	25418-001

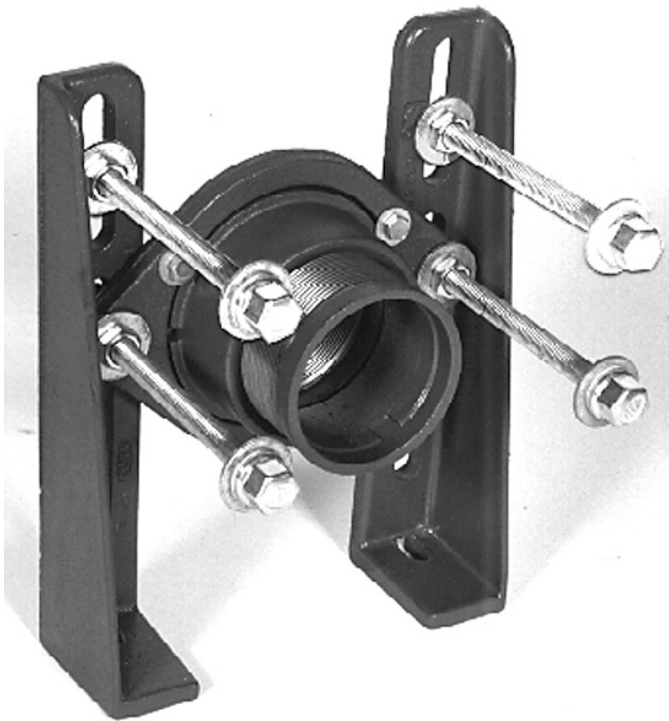

# Z1212 INSTALLATION INSTRUCTIONS

1. Secure nose piece to flange using 3/8 washers and H.H.C.S. provided.
2. Insert O-Ring into O-ring groove located inside nose piece.
3. Apply vaseline to O-ring and coupling threads, then thread coupling into nose piece until it meets the O-ring, recognizable by the feel of resistance to the turning motion. Then use the coupling wrench to turn the coupling into the O-ring, thus obtaining a water tight seal.
4. Using (2) 5/8 x 9" studs (4) 5/8 steel washers and (4) 5/8 jam nuts attach the previously assembled parts to the uprights so that the distance from the center of the coupling to the bottom of the uprights is equal to the sum of the finished floor thickness plus the manufacturer's suggested outlet height.
5. Using (4) 5/8 washers and (4) 5/8 jam nuts secure the last two remaining 5/8 x 9" studs to the uprights so that their centers when measured vertically from the center of the coupling are both 7 1/2".
6. Using 1/2 anchor bolts supplied by others mount the assembled Z1212 to the concrete so that the face of the uprights are 1" to 2" maximum from the finished wall.
7. Thread (1) 5/8 jam nut onto each of the (4) 5/8 x 9" studs along with sliding on (4) 5/8" steel washers. Adjust the jam nuts so that the steel washers will protrude past the finished wall 1/16".
8. Using the formula to the right adjust the coupling so that its face is past the finished wall the distance equal to 'B'.
9. Clean gasket recess and coupling face with clean dry cloth. Apply cement to coupling face. Remove gasket insert and press gasket against face of coupling allow to dry.
10. Apply cement to face of gasket and recess in water closet. Slide water closet over studs and cut studs off so that they extend approximately 1/2" past the flange of the water closet. Slide on (1) 5/8 plastic washer to each stud and tighten water closet to Z1212 carrier using 5/8 cap nuts.

## FORMULA FOR DETERMINING DISTANCE COUPLING SHOULD EXTEND FROM FINISHED WALL

- Let 'A' = Depth of recess in water closet  
'X' = Distance water closet is to be located from finished wall (usually 1/16")  
'B' = Distance coupling should extend in front of the finished wall  
Thus,  $A + X - 1/2" = B$

With fixtures having V shaped grooves, coupling may have to extend an additional 1/8" or more. With any water closet, the coupling must compress the gasket enough so the adhesive coated surfaces are in good contact with the china and the face of the coupling.

**IMPORTANT:** Bearing nuts and washers must be located properly to establish and maintain dimension 'X'.

