



P6-AWG
6 [152] Wide Domestic Grate

Dimensional Data (Imperial and [Metric]) are subject to manufacturing tolerances and change without notice. Linear (in[mm]), Area (in²[mm²], & Weight (lbs[kg]).

[Back to Index](#)

Please Check	Item No.	Part Number	Item I.D.
✓	1	94081	P6-AWG

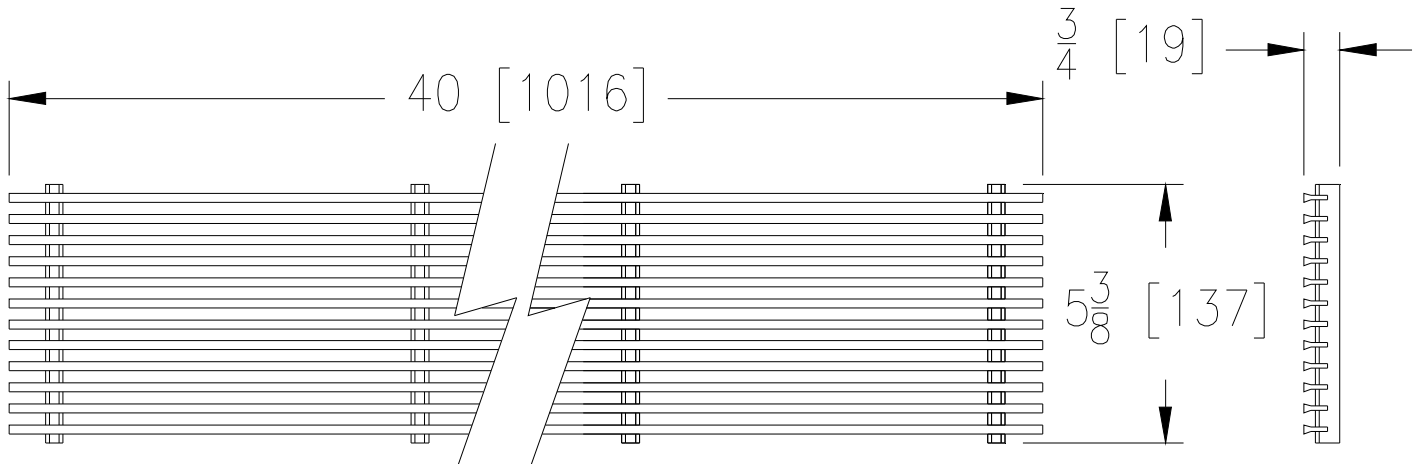

AWG GRATE ENGINEERING SPECIFICATION: ZURN P6-AWG

40" [1016mm] X 5-3/8" [137mm] Aluminum wire grate, weighing .9 lbs per linear foot [1.3kg./m]. The grate has an open area of 37.5 in² per linear foot [794cm²/m], DIN rating of A, ANSI rating of Light-Duty, ADA Compliant, Aluminum members conform to ASTM specification 6061 u-chips conform to ASTM specification 5052.



AWG - Wire Grate	
Material:	Aluminum
DIN Rating:	Class A
Weight:	.9 lbs/ft. [1.3kg/m]
Open Area:	37.5 in ² /ft. [794cm ² /m]
ANSI Rating:	Light-Duty
Application:	Decorative Heel-Proof
Slot Width/Hole Size:	1/4" [6.4mm]
ADA:	Yes
H-20:	No
FAA:	No



P6-HPP

6 [152] Wide Grate

Dimensional Data (Imperial and [Metric]) are subject to manufacturing tolerances and change without notice. Linear (in/[mm]), Area (in²/[mm²], & Weight (lbs/[kg]).

[Back to Index](#)

Please Check	Item No.	Part Number	Item I.D.
✓	36	94001	P6-HPP

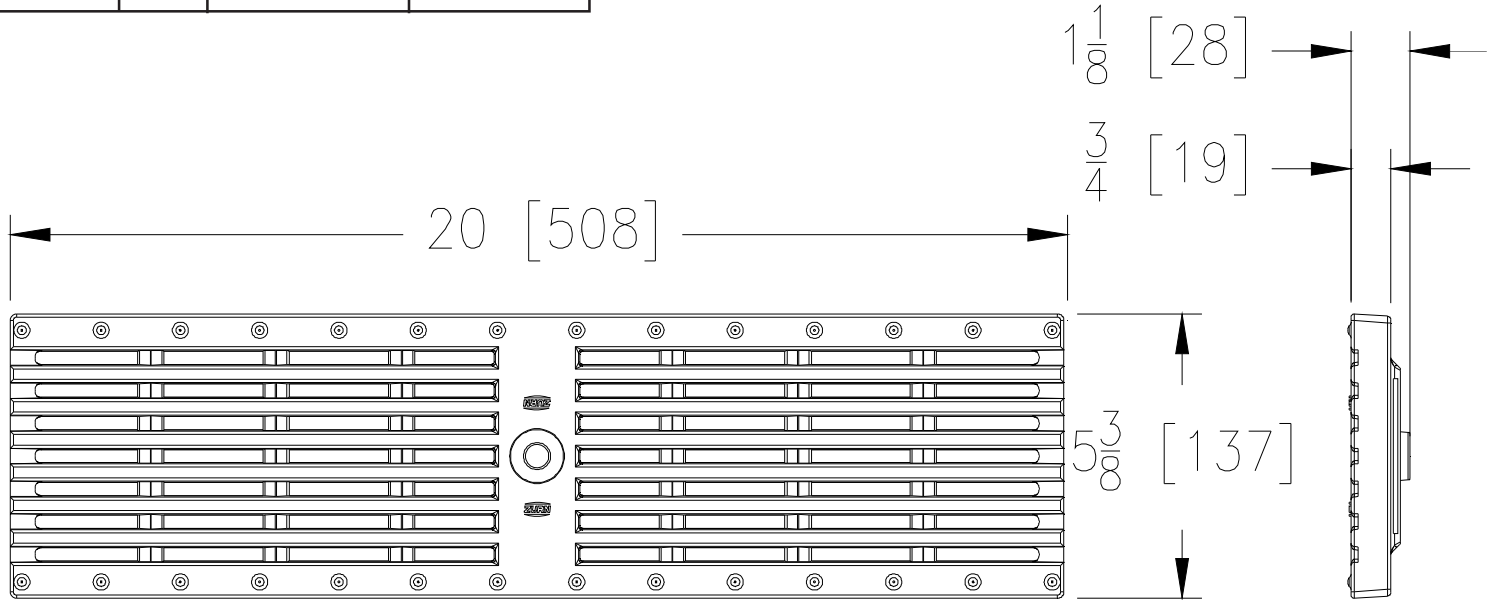

HPP GRATE ENGINEERING SPECIFICATION: ZURN P6-HPP

20" [508mm] X 5-3/8" [137mm] High Density Polyethylene (HDPE) heel-proof slotted grate weighing .9 lbs per linear foot [1.3kg/m]. The grate has an open area of 17.4 in² per linear foot [367cm²/m]. Grate conforms to DIN rating of A, ANSI rating of Light-Duty, ADA compliant*, and Densetec 100 HDPE or Approved Equivalent.

HPP - Heel-Proof Slotted	
Material:	HDPE
DIN Rating:	Class A
Weight:	.9 lbs/ft. [1.3kg/m]
Open Area:	17.4 in ² /ft. [367cm ² /m]
ANSI Rating:	Light-Duty
Application:	Heel-Proof, Pedestrian
Slot Width/Hole Size:	1/4" [6.4mm]
ADA:	Yes*
H-20:	No
FAA:	No

* Elongated openings must be placed perpendicular to the dominant direction of travel.



P886-PVSS

6 [152] Wide Domestic Decorative Grate

Dimensional Data (Imperial and [Metric]) are subject to manufacturing tolerances and change without notice. Linear (in/[mm]), Area (in²/[mm²], & Weight (lbs/[kg]).

[Back to Index](#)

Please Check	Item No.	Part Number	Item I.D.
✓	70	94287	P886-PVSS

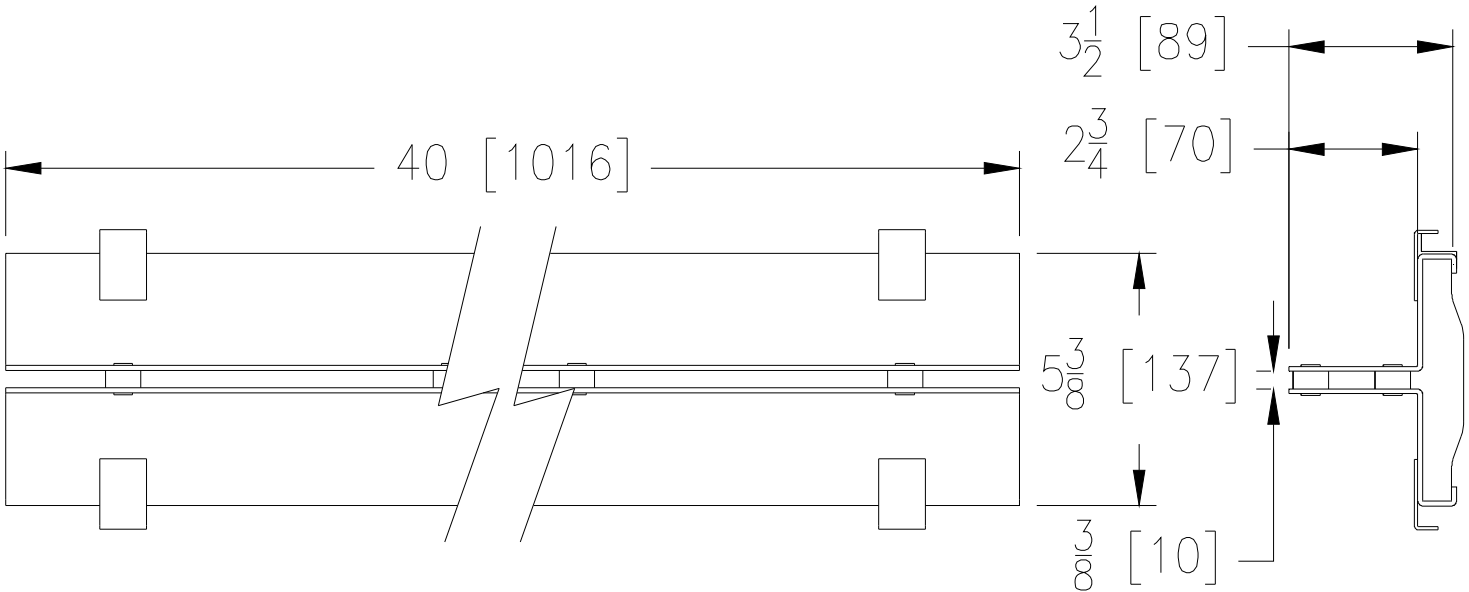

PVSS GRATE ENGINEERING SPECIFICATION: ZURN P886-PVSS

40" [1016mm] X 5-3/8" [137mm] Fabricated stainless steel paver slot grate weighing 4.7 lbs per linear foot [6.9kg/m]. The grate has an open area of 6.0 in² per linear foot [128cm²/m]. Grate conforms to DIN rating of B, ANSI rating of Medium-Duty, ADA compliant* and ASTM A-240 Type 304 (316 by request). (Only available with Z886 trench drain system)



PVSS - Paver Slot Grate	
Material:	Stainless Steel
DIN Rating:	Class B
Weight:	4.7 lbs/ft. [6.9kg/m]
Open Area:	6.0 in ² /ft. [128cm ² /m]
ANSI Rating:	Medium-Duty
Application:	Sidewalks, Light-Traffic
Slot Width/Hole Size:	1/2" [12.7mm]
ADA:	Yes*
H-20:	No
FAA:	No

* Elongated openings must be placed perpendicular to the dominant direction of travel.