



# PRE-RINSE UNIT

G62740

TAG \_\_\_\_\_

## Engineering Specification: Zurn AquaSpec® G62740

Angled self-closing 1.6 GPM [6L] pre-rinse valve with a stay open ring and rubber bumper spray head. Unit has a 3/4-14 UNS threaded male inlet. Fits all major manufacturers.

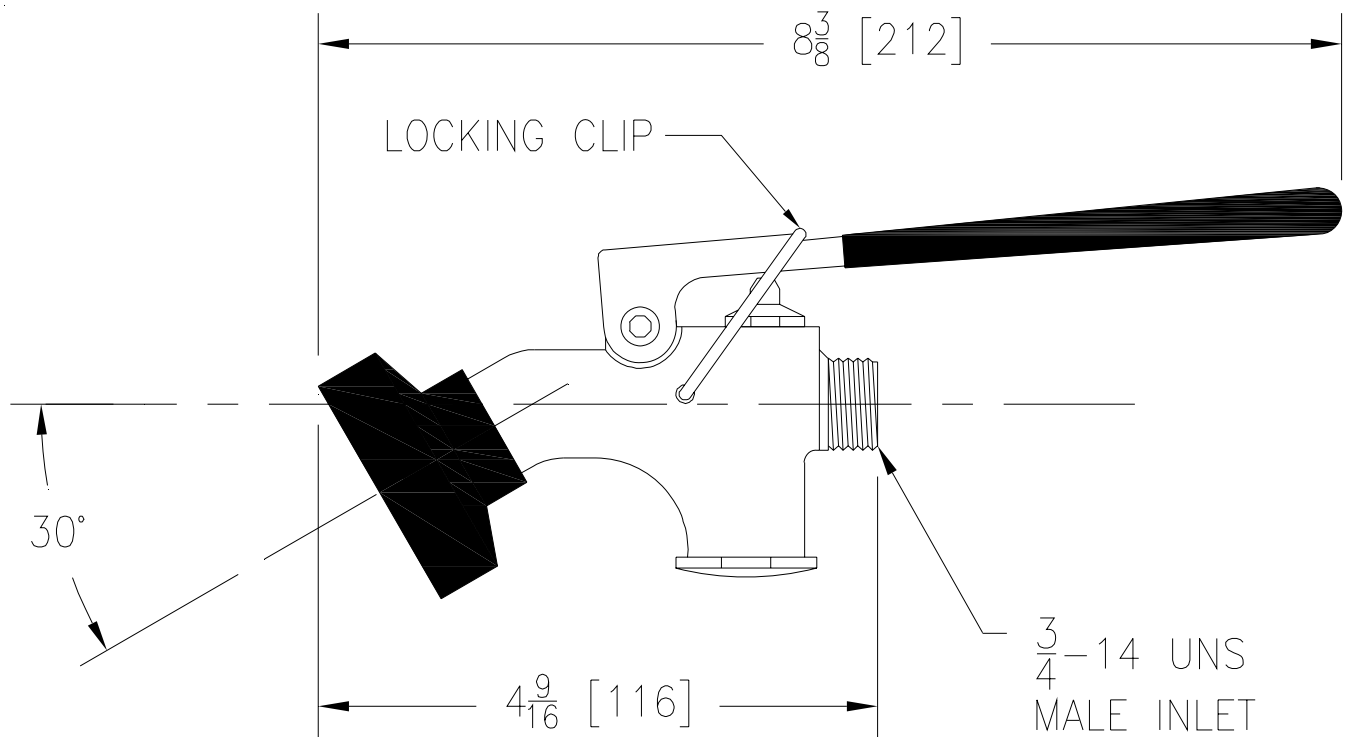

Note: All dimensions are for reference only. Do not use for pre-plumbing.

### OPTIONAL ACCESSORIES

No options required.

ZURN INDUSTRIES, INC. ♦ COMMERCIAL BRASS OPERATION ♦ 2640 SOUTH WORK STREET ♦ FALCONER NY 14733

Phone: 1-716-665-1132 ♦ Fax: 1-716-665-1135 ♦ World Wide Web: [www.zurn.com](http://www.zurn.com)

In Canada: ZURN INDUSTRIES LIMITED ♦ 3544 Nashua Drive ♦ Mississauga, Ontario L4V1L2 ♦ Phone: 905/405-8272 Fax: 905/405-1292