



Model Z5655.213.00.00.00

1.28 gpf Elongated Floor Mounted EcoVantage®
Sensor Flush Valve Toilet System

TAG _____

Z5655 HET Series

- Zurn One HET Toilet System designed for optimal performance between Zurn fixture and Zurn flush valve to save water.
- 1.28 gpf (gallons per flush) [4.8 Lpf]
- 20% water savings over standard 1.6 gpf [6.0 Lpf] system
- Vitreous china
- Top Spud/Exposed System
- Elongated front rim
- 2-1/8" fully glazed trapway
- High efficiency siphon jet flush action
- Zurn product system component compatibility and quality assurance
- Shipping Weight: 64 lbs.



Z5655 Series Elongated

Recommended Trim:

- Z5955SS-EL** Elongated, standard white, open front toilet seat less cover with stainless steel check hinge.
- Z5972-COMB** Closet bolt/wax ring kit.

Note: To ensure system performance:

Minimum Running Water Pressure = 25 psi.

Engineering Specification

Z5655.213 EcoVantage® High Efficiency Toilet System - System comes complete with exposed sensor operated ZTR6200EV high efficiency flushometer valve, floor mounted, and vitreous china toilet. The system is designed to perform to industry standards with as little as 1.28 gallons per flush [4.8 Lpf]. The EcoVantage® sensor valve is operated by an infrared convergence-type proximity sensor with smart technology, powered by 4 "AA" batteries, furnished with a vandal resistant chrome plated cast brass valve body, chloramine resistant internal seals, manual override button and reversible cover, high back pressure vacuum breaker, one piece hex coupling nut, adjustable tailpiece, spud coupling nut, flange for top spud connection. Control stop has internal siphon guard protection. Internal seals are made of chloramine resistant materials. Vitreous china toilet is 1-1/2" top spud with 2-1/8" fully glazed trapway and siphon jet action. Valve and toilet are an engineered system designed to provide optimal performance and 20% water savings over 1.6 gpf [6.0 Lpf] conventional toilets.



This product should be used with a WaterSense labeled counterpart with a compatible flush volume to ensure that the entire system meets the requirements for water efficiency and performance.

Fixture dimensions meet ANSI/ASME standard A112.19.2 and CAN/CSA B45 requirements.

In Canada - Consult local codes and standards.

EcoVantage® and AquaVantage® are registered trademarks of Zurn Industries

All dimensions and specifications are subject to change without notice.

This space is for Architectural/engineering Approval

Zurn Industries, LLC
5900 Elwin Buchanan Drive, Sanford, NC U.S.A. 27330 · Ph. 1-800-997-3876, Fax 919-775-3541

In Canada | **Zurn Industries Limited**
7900 Goreway Drive Unit 10, Brampton, Ontario L6T5W6 · Ph. 905-405-8272, Fax 905-405-1292

www.zurn.com

Rev. -
Date: 10/27/2017
C.N. No. SAN007892
Prod. | Dwg. No. 317213



Model Z5655.213.00.00.00

1.28 gpf Elongated Floor Mounted EcoVantage®
Sensor Flush Valve Toilet System

TAG _____

Rough-in dimensions for Z5655 Series

- Z5655.213.00.00.00 with top spud

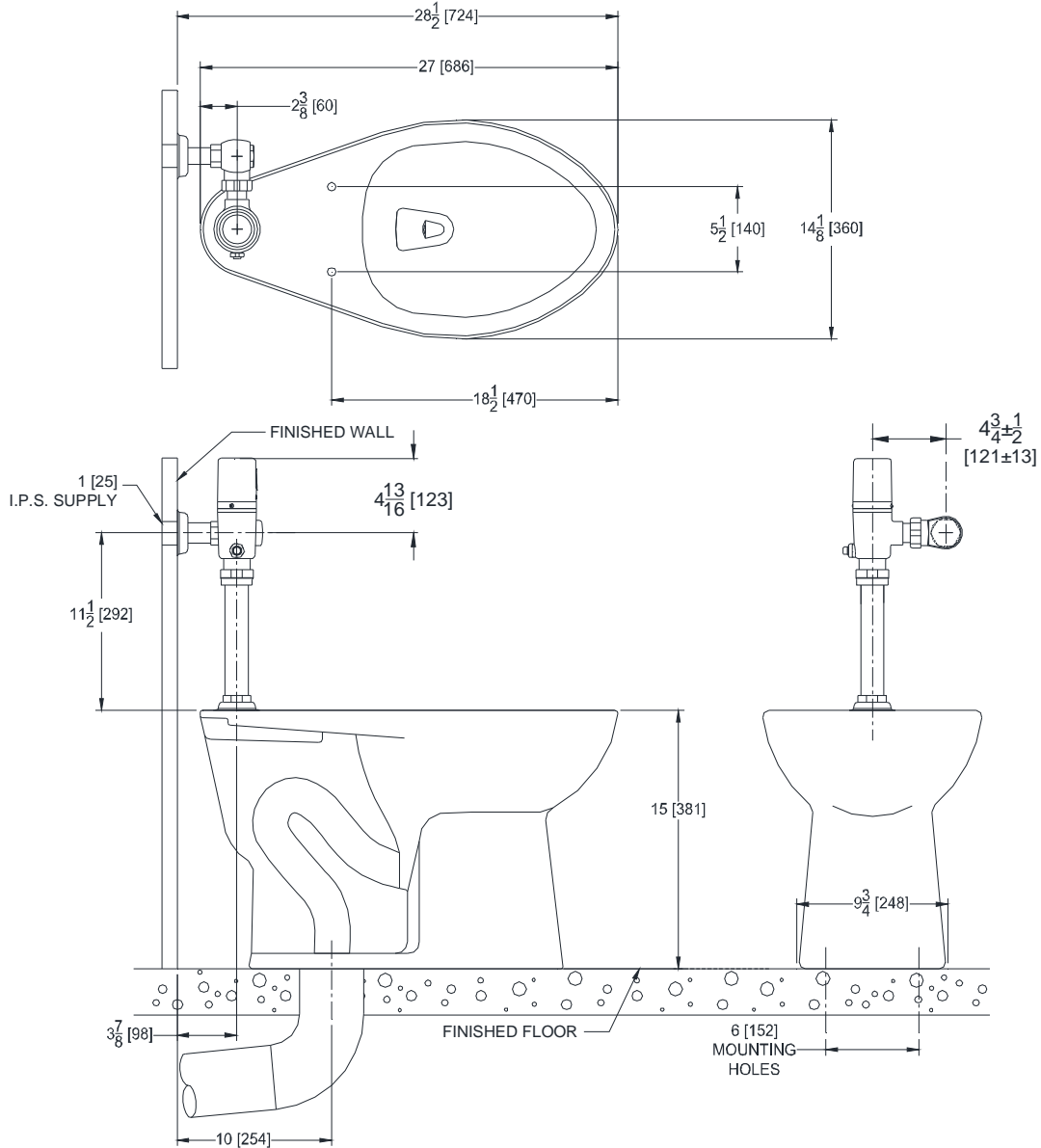

Fixture dimensions meet ANSI/ASME standard A112.19.2 and CAN/CSA B45 requirements.

In Canada - Consult local codes and standards.

EcoVantage® and AquaVantage® are registered trademarks of Zurn Industries

All dimensions and specifications are subject to change without notice.