



Product information presented here reflects conditions at time of publication. Consult factory regarding discrepancies or inconsistencies.

MAIL TO: P.O. BOX 16347 • Louisville, KY 40256-0347  
SHIP TO: 3649 Cane Run Road • Louisville, KY 40211-1961  
(502) 778-2731 • 1 (800) 928-PUMP • FAX (502) 774-3624

visit our web site:  
[www.zoeller.com](http://www.zoeller.com)

**COMPARE THESE FEATURES**

- Non-clogging vortex impeller design. Bronze class 84-8-0-4
- Durable cast construction. Cast iron switch case, base, motor and pump housing. No sheet metal parts to rust or corrode. All cast iron class 25-30 25000# tensile strength
- Stainless steel screws, bolts, float rod, handle, guard, arm and seal assembly
- 20 ft. UL Listed 3-wire neoprene cord and plug. Extra cord lengths available in 25-35-50 foot lengths only.
- 3 phase models available (292, 115V/1Ph only)
- Motor - 60 Hz, 3450 RPM, oil-filled, hermetically sealed, automatic reset, thermal overload protected (1 Ph only)
- Maximum temperature for sewage or dewatering 130°F (54°C), 120°F (49°C) for WD295. If over 130°F, consult Factory.
- Shaft Seal - Stainless steel carbon & ceramic rotary
- Corrosion resistant powder coated epoxy finish
- Upper & lower ball bearings running in bath of oil
- Square Ring & Gasket - Neoprene
- All models pass 2" spherical solids.
- Major width 12 7/8" • Height 19 5/16" (Single seal pumps)
- Automatic units available with float operated, submersible (NEMA 6) 2-pole mechanical switch. On point 14 3/4" - Off point 5"
- Specify 2" or 3" NPT female flanged vertical discharge.
- 100% computerized testing

**MODELS 4292-4293-4294-4295 DOUBLE SEAL PUMPS (Nonauto only)**

- Gives motor extra protection from seal leaks
- Improved bearing lubrication
- Helps eliminate seal and bearing damage from dry runs
- Major width 12 7/8" Height 21 3/16"

**Note:** The sizing of effluent systems normally requires variable level float(s) controls and properly sized basins to achieve required pumping cycles or dosing timers with nonautomatic pumps.

**292 - 293 - 294 - 295 Single Seal Series**  
**4292 - 4293 - 4294 - 4295 Double Seal Series**  
(For Pump Prefix Identification see News & Views 0052)

**HIGH HEAD**  
**"WASTE-MATE"**  
SUBMERSIBLE  
**SEWAGE**  
OR DEWATERING PUMP

  
Certified to CSA  
Standard C22.2 No.108

  
Tested to UL  
Standard UL778

  
QUALITY MADE  
America's  
Best S.  
Craftsmen

  
SSPMA  
Certified  
50  
YEARS

Nonautomatic models for variable level systems

POWDER COATED TOUGH™

Double Seal Pump

  

Automatic units available in single phase 292, 293, 294 & 295 series

WD295 controlled by variable level float switch

\*See back page for UL & CSA listings

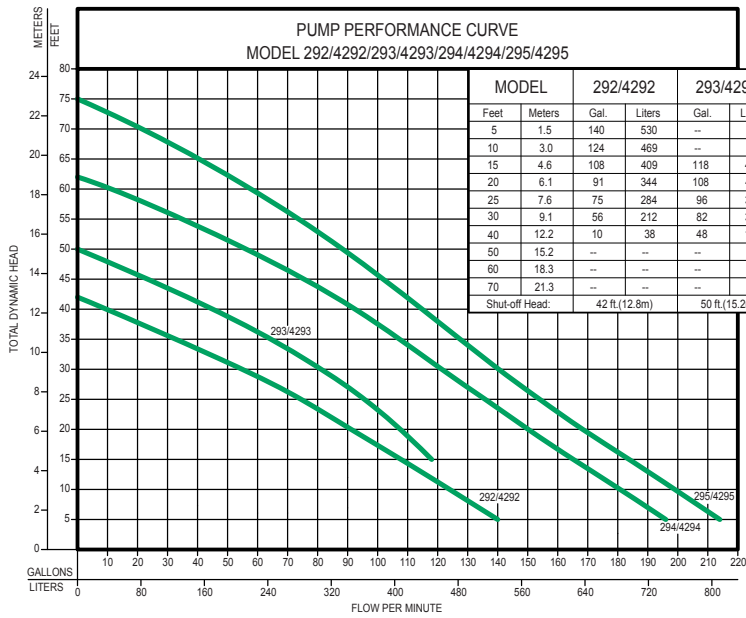

**CAUTION**  
Model 293 should not be subjected to less than 15' TDH.

**Single Seal Automatic Design  
Weight 86-89 lbs.**

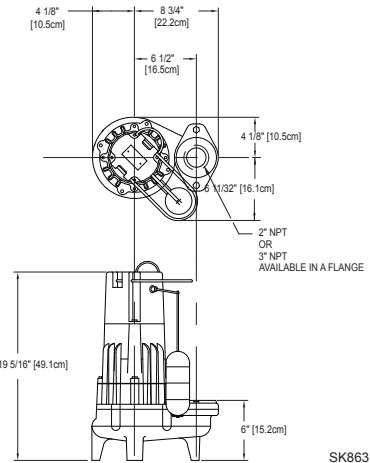

009919A

SK863

292 MODELS	4292 MODELS	Standard all models - 20 ft. cord - 1/2 HP				Control Selection		Listings	
Single Seal	Double Seal	Volts - Ph	Mode	Amps	Simplex	Duplex	CSA	UL	
M292	---	115	1	Auto	15.0	1	---	Y Y	
N292	N4292	115	1	Non	15.0	2 or 3	2 or 4	Y Y <sup>(1)</sup>	
* BA292	* BA4292	575	3	Non	2.4	3	4	Y N	

293 MODELS	4293 MODELS	Standard all models - 20 ft. cord - 1 HP				Control Selection		Listings	
Single Seal	Double Seal	Volts - Ph	Mode	Amps	Simplex	Duplex	CSA	UL	
D293	---	230	1	Auto	10.2	1	---	Y Y	
E293	E4293	230	1	Non	10.2	2 or 3	4	Y Y	
* H293	---	200	1	Auto	12.0	1	---	Y N	
* I 293	* I 4293	200	1	Non	12.0	2 or 3	4	Y N	
* F293	* F4293	230	3	Non	7.6	3	4	Y Y	
* J293	* J4293	200	3	Non	8.2	3	4	Y Y	
* G293	* G4293	460	3	Non	4.0	3	4	Y Y	
* BA293	---	575	3	Non	3.3	3	4	Y N	

294 MODELS	4294 MODELS	Standard all models - 20 ft. cord - 1 1/2 HP				Control Selection		Listings	
Single Seal	Double Seal	Volts - Ph	Mode	Amps	Simplex	Duplex	CSA	UL	
D294	---	230	1	Auto	13.7	1	---	Y Y <sup>(1)</sup>	
E294	E4294	230	1	Non	13.7	2 or 3	4	Y Y <sup>(1)</sup>	
* H294	---	200	1	Auto	17.8	1	---	Y N	
* I 294	* I 4294	200	1	Non	17.8	2 or 3	4	Y N	
* F294	* F4294	230	3	Non	9.5	3	4	Y Y	
* J294	* J4294	200	3	Non	10.8	3	4	Y Y	
* G294	* G4294	460	3	Non	4.8	3	4	Y Y	
* BA294	---	575	3	Non	3.8	3	4	Y N	

295 MODELS	4295 MODELS	Standard all models - 20 ft. cord - 2 HP				Control Selection		Listings	
Single Seal	Double Seal	Volts - Ph	Mode	Amps	Simplex	Duplex	CSA	UL	
D295	---	230	1	Auto	17.1	1	---	Y <sup>(2)</sup> Y	
E295	E4295	230	1	Non	17.1	2 or 3	4	Y <sup>(2)</sup> Y	
WD295	---	230	1	Auto	17.1	**	4	N N	
* H295	---	200	1	Auto	20.5	1	---	Y N	
* I 295	* I 4295	200	1	Non	20.5	2 or 3	4	Y N	
* F295	* F4295	230	3	Non	12.2	3	4	Y Y	
* J295	* J4295	200	3	Non	14.3	3	4	Y Y	
* G295	* G4295	460	3	Non	6.1	3	4	Y Y	
* BA295	---	575	3	Non	4.9	3	4	Y N	

**Double Seal Design / Weight 92-95 lbs.**

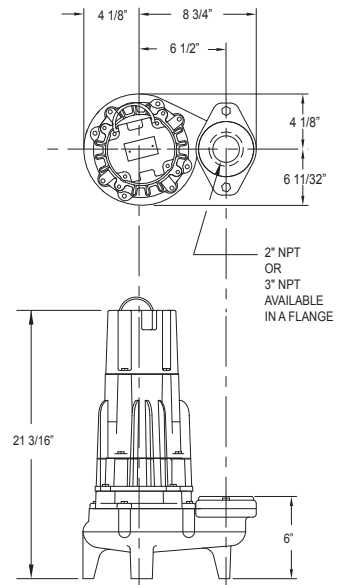

SK1415

**SELECTION GUIDE**

1. Integral float operated mechanical switch, no external control required.
2. For automatic use single piggyback variable level float switch or double piggyback variable level float switch. Refer to FM0477.
3. See FM1228 for correct model of simplex control panel.
4. See FM0712 for correct model of duplex control panel.

**CAUTION**

All installation of controls, protection devices and wiring should be done by a qualified licensed electrician. All electrical and safety codes should be followed including the most recent National Electrical Code (NEC) and the Occupational Safety and Health Act (OSHA).

For information on additional Zoeller products refer to catalog on Explosion Proof Models, FM1702; Simplex controls, FM1596; Piggyback Variable Level Float Switches, FM0477; Electrical Alternator, FM0486; Mechanical Alternator, FM0495; Sump/Sewage Basins, FM0487; Alarm Systems, FM0732; Disconnect/Rail Systems, FM0787; and Junction Boxes FM1597.

\* No Molded Plug.  
\*\* Single piggyback switch included.  
(1) UL Listed unit available with 20 Amp plug.  
(2) CSA Approval with 20 Amp plug.

**RESERVE POWERED DESIGN**

For unusual conditions a reserve safety factor is engineered into the design of every Zoeller pump.

© Copyright 2012 Zoeller Co. All rights reserved.