

MAIL TO: P.O. BOX 16347 • Louisville, KY 40256-0347
 SHIP TO: 3649 Cane Run Road • Louisville, KY 40211-1961
 Tel: (502) 778-2731 • 1 (800) 928-PUMP

Visit our website:
 zoellerpumps.com

Product information presented here reflects conditions at time of publication. Consult factory regarding discrepancies or inconsistencies.



TECHNICAL DATA SHEET

MODEL 840 & 841

DUAL SEAL GRINDER PUMPS

Pump Systems And Controls

PRODUCT SPECIFICATIONS

MOTOR	Horse Power	2
	Voltage	200 - 460
	Phase	1 or 3 Ph
	Hertz	60 Hz
	RPM	3450
	Type	Capacitor start / capacitor run or 3 Ph
	Insulation	Class F
	Amps	5.5 - 20.0
PUMP	Operation	Nonautomatic
	Discharge Size	1-1/4" NPT vertical or horizontal
	Cord Length	20' (6 m) standard
	Cord Type	SOW or SOOW, multi-wire neoprene
	Max. Head	125' (38.1 m)
	Max. Flow Rate	59 GPM (223 LPM)
	Max. Operating Temp.	130 °F (54 °C)
	Cooling	Oil filled
MATERIALS	Motor Protection	Auto reset thermal overload (1 Ph), thermal sensor (3 Ph) Moisture Sensors
	Cap	Cast iron
	Motor Housing	Cast iron
	Adapter	Cast iron
	Pump Housing	Cast iron
	Upper Bearing	Ball bearing
	Lower Bearing	Ball bearing
	Mechanical Seals	Carbon/ceramic
	Impeller Type	Non-clogging vortex
	Impeller	Ductile iron
	Hardware	Stainless steel 304
	Motor Shaft	Stainless steel 416
	Square Rings	Neoprene
	Cutter	Hardened stainless steel, Rockwell C55-60

Model 840 (Reversing Grinder Pump)

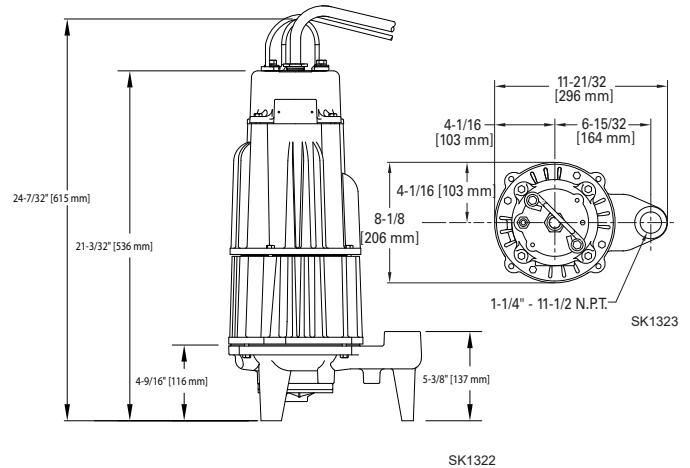

Model 841 Vertical Discharge

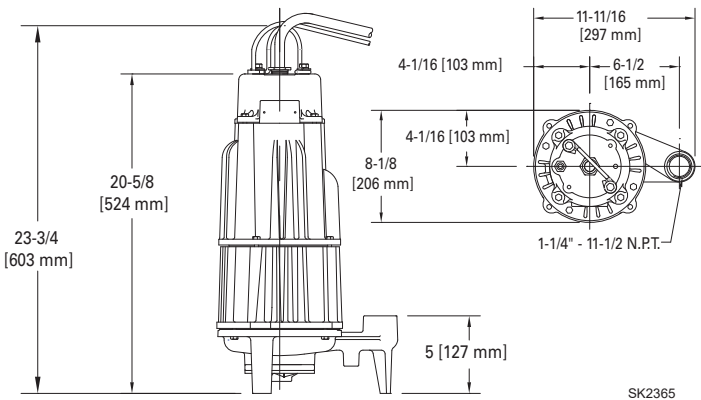

C US
 Tested to Standard UL778 and
 Certified to CSA
 Standard C22.2 No. 108



TOTAL DYNAMIC HEAD FLOW PER MINUTE

MODEL		840		841	
Feet	Meters	Gal.	Liters	Gal.	Liters
5	1.5	45	170	54	204
10	3.0	45	170	54	204
20	6.1	45	170	54	204
30	9.1	44	167	54	204
40	12.2	42	159	54	204
50	15.2	36	136	52	197
60	18.3	30	114	49	185
70	21.3	23	87	43	163
80	24.4	16	61	36	136
90	27.4	10	38	28	106
100	30.5	3	11	19	72
110	33.5	--	--	11	42
120	36.6	--	--	4	15
Shut-off Head:		104 ft (31.7 m)		125 ft (38.1 m)	

016532

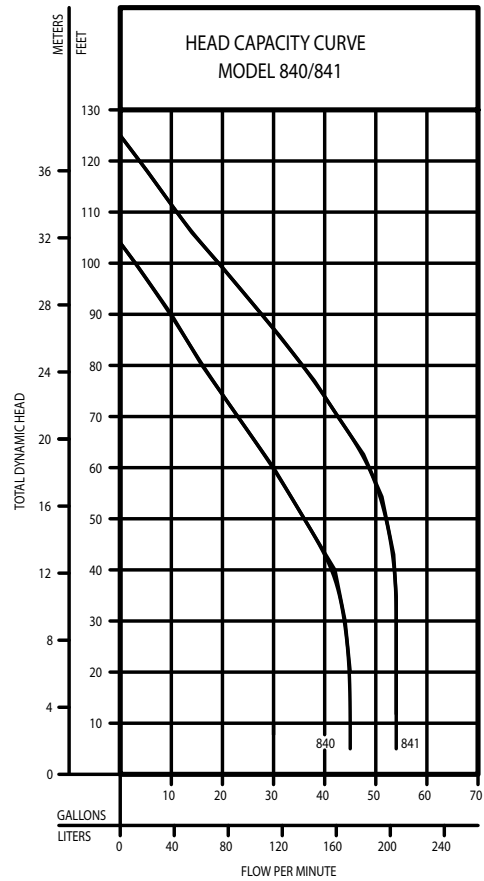

ELECTRICAL DATA AND CONTROL PANEL SELECTION GUIDE					
A) Models	Weight	Volts / Phase	Amps	B) NEMA 4X Control Panels	
840 REVERSING GRINDER				SIMPLEX	DUPLEX
E840*	137 lbs (62.1 Kg)	230 / 1	17.2	23734-0001	24734-0001
I840*	137 lbs (62.1 Kg)	200 / 1	20.0	23734-0001	24734-0001
F840	132 lbs (59.8 Kg)	230 / 3	10.8	234F4-0001	244F4-0001
J840	132 lbs (59.8 Kg)	200 / 3	12.3	234F4-0001	244F4-0001
G840	132 lbs (59.8 Kg)	460 / 3	5.5	234D4-0001	244D4-0001
841 SINGLE DIRECTION GRINDER				SIMPLEX	DUPLEX
E841*	137 lbs (62.1 Kg)	230 / 1	17.2	21734-0001	22734-0001
I841*	137 lbs (62.1 Kg)	200 / 1	20.0	21734-0001	22734-0001
F841	132 lbs (59.8 Kg)	230 / 3	10.8	114F4-0001	124F4-0001
J841	132 lbs (59.8 Kg)	200 / 3	12.3	114F4-0001	124F4-0001
G841	132 lbs (59.8 Kg)	460 / 3	5.5	114D4-0001	124D4-0001

B) CONTROL PANEL STANDARD FEATURES:

- NEMA 4X outdoor rating
- Automatic reversing circuit (840 model only)
- Audible and visual high water alarm
- Starting, control, and alarm circuits
- Thermal cut-out circuit (3 Ph only)
- Circuit breaker and rated motor contactor (1 Ph)
- Capacitors and motor starting relay on (1 PH)
- Motor protective switch (circuit breaker / phase adjustable overloads) and rated motor contactor (3 Ph)
- Alternating circuit (duplex)
- High water alarm light
- Internal seal leak light
- HOA switches and pilot light(s)
- Terminal strips
- Padlock hasp
- Flasher for high water alarm light
- Dry auxiliary contact
- Elapsed time meters

* Single phase units require a set of capacitors and relay starting components, included in panel

STARTER KITS*		
P/N	Pump Model	Type
10-0380	840 & 841	Shipped Loose
*Starter kits needed if using existing panels and single phase (E or I model) grinder pumps		



All installation of controls, protection devices and wiring should be done by a qualified licensed electrician. All electrical and safety codes should be followed including the most recent National Electrical Code (NEC) and the Occupational Safety and Health Act (OSHA).

C) VARIABLE LEVEL FLOAT SWITCHES

INDOOR SYSTEM

- 3 Switches and weights
- P/N 10-0347 WGT. 9.5 lb (4.3 kg)
- 4 Switches and weights
- P/N 10-0348 WGT. 13 lb (5.9 kg)

OUTDOOR SYSTEM

- Switches with pipe clamps, 3 required
- P/N 10-0744 20' WGT. 2 lb (kg)
- P/N 10-1878 35' WGT. 3 lb (kg)
- P/N 10-1879 50' WGT. 4.0 lb (kg)

D) JUNCTION BOXES - TYPE 4X

SIMPLEX

- 5 holes with seals for (1) power cord, (1) sensor cord, (3) float switch cords.
- P/N 10-0331 WGT. 2.5 lb (1.1 kg) 3-float system
- P/N 10-4508 Simplex J-box

DUPLEX

- 8 holes with seals for (2) power cords, (2) sensor cords, (3 or 4) float switch cords.
- P/N 10-0332 WGT. 2.5 lb (1.1 kg) 3-float system
- P/N 10-0421 WGT. 2.5 lb (1.1 kg) 4-float system
- P/N 10-4509 Duplex J-box

F) OUTDOOR BASIN, COVER, AND RAIL SYSTEM

BASIN - STANDARD EQUIPMENT

- Fiberglass basin with anti-flotation ring
- 1.25" X 2" Z-Rail® disconnect system w/ 3/4" galvanized rail pipes
- 2" SCH. 80 PVC discharge pipe from disconnect
- 2" Flex boot discharge fitting
- Stainless steel lifting cable
- 2" PVC ball valve(s)
- 2" cast iron check valve(s)
- (1)-4" rubber inlet pipe seal (field-installed)
- Float tree
- Blank fiberglass cover with Zoeller imprint

SIMPLEX

- | | | |
|---|-------------|---------------------------|
| <input type="checkbox"/> 24" x 48" (61 x 122 cm) | P/N 33-2054 | WGT. 180 lb (93.4 kg)15" |
| <input type="checkbox"/> 24" x 60" (61 x 152 cm) | P/N 33-2057 | WGT. 187 lb (99.3 kg)24" |
| <input type="checkbox"/> 24" x 72" (61 x 183 cm) | P/N 33-2060 | WGT. 192 lb (105.7 kg)30" |
| <input type="checkbox"/> 24" x 84" (61 x 213 cm) | P/N 33-2063 | WGT. 213 lb (119.7 kg)36" |
| <input type="checkbox"/> 24" x 96" (61 x 244 cm) | P/N 33-2069 | WGT. 230 lb (125.6 kg)36" |
| <input type="checkbox"/> 24" x 108" (61 x 244 cm) | P/N 33-2075 | WGT. 248 lb (125.6 kg)48" |
| <input type="checkbox"/> 24" x 120" (61 x 244 cm) | P/N 33-2078 | WGT. 260 lb (125.6 kg)48" |

DUPLEX

- | | | |
|---|-------------|---------------------------|
| <input type="checkbox"/> 36" x 48" (91 x 122 cm) | P/N 33-2108 | WGT. 258 lb (166.5 kg)19" |
| <input type="checkbox"/> 36" x 60" (91 x 152 cm) | P/N 33-2111 | WGT. 272 lb (176.4 kg)24" |
| <input type="checkbox"/> 36" x 72" (91 x 183 cm) | P/N 33-2114 | WGT. 285 lb (214.1 kg)30" |
| <input type="checkbox"/> 36" x 84" (91 x 213 cm) | P/N 33-2117 | WGT. 304 lb (226.3 kg)36" |
| <input type="checkbox"/> 36" x 96" (91 x 244 cm) | P/N 33-2123 | WGT. 332 lb (238.1 kg)36" |
| <input type="checkbox"/> 36" x 108" (91 x 244 cm) | P/N 33-2129 | WGT. 359 lb (163 kg)48" |
| <input type="checkbox"/> 36" x 120" (91 x 244 cm) | P/N 33-2132 | WGT. 379 lb (172 kg)48" |

Note: 30" diameter simplex and 48" diameter duplex system also available

PREPACKAGED AND JOB READY SYSTEMS CHECKLIST

OUTDOOR			
SIMPLEX		DUPLEX	
REQ.	REQ.	REQ.	REQ.
1 grinder pump	P/N _____ (A)	2 grinders pumps	P/N _____ (A)
1 simplex control panel	P/N _____ (B)	1 duplex control panel	P/N _____ (B)
3 float switches	P/N _____ (C)	3 or 4 float switches	P/N _____ (C)
1 j-box (optional)	P/N _____ (D)	1 j-box (optional)	P/N _____ (D)
1 basin, cover and hardware	P/N _____ (F)	1 basin, cover and hardware	P/N _____ (F)

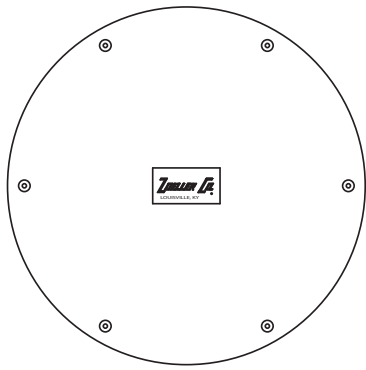

SOLID FIBERGLASS COVER

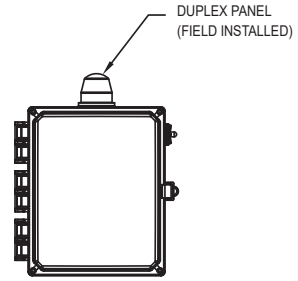
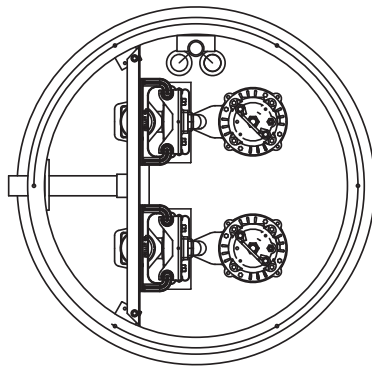

DUPLEX PANEL
(FIELD INSTALLED)

1/8" 302 STAINLESS STEEL LIFTING CABLE

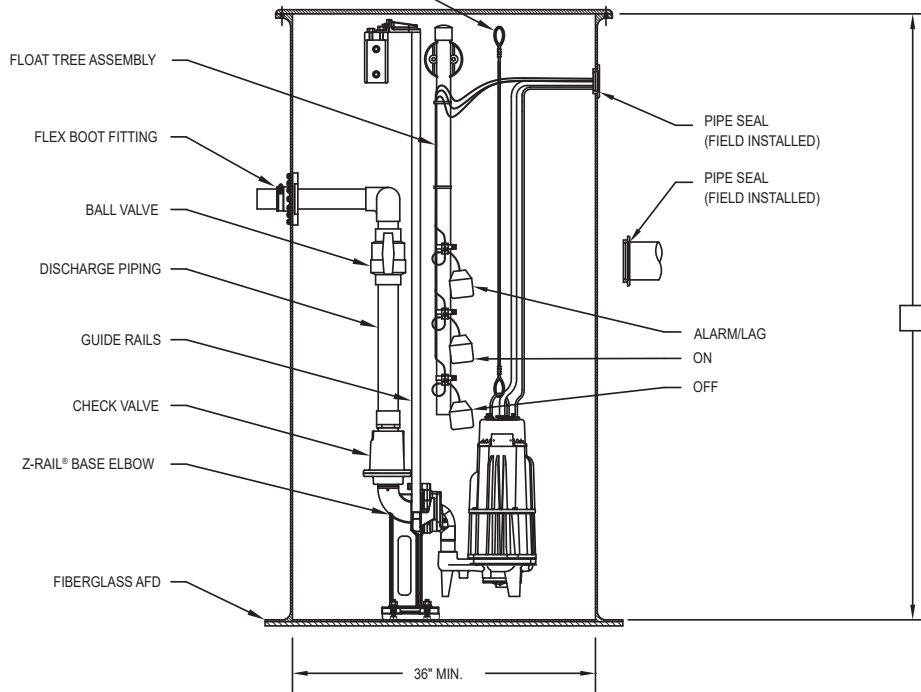

SK3111

840/841 Horizontal Discharge Dimensional Data

840

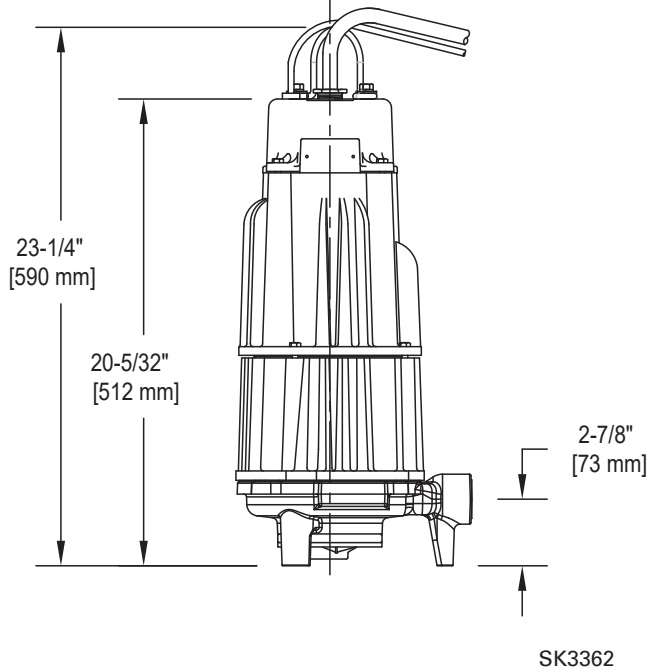
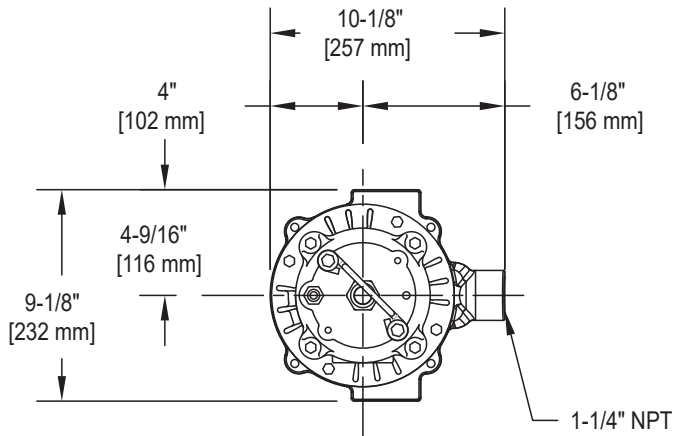

841

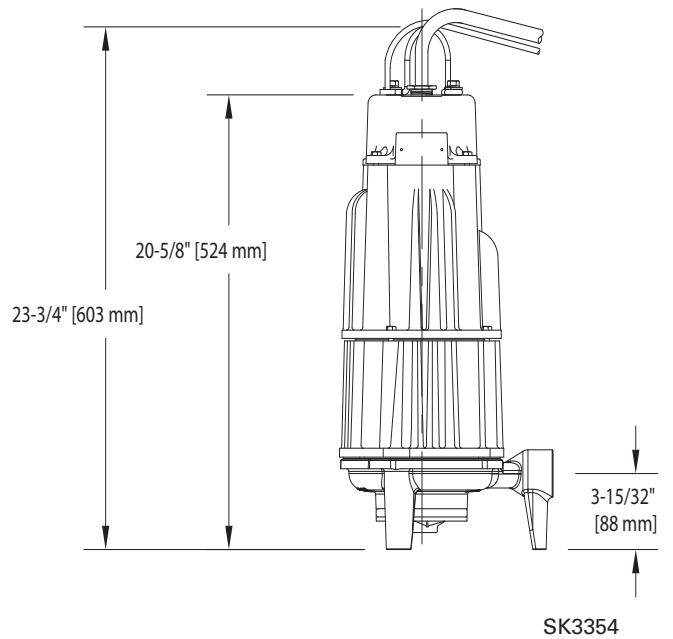
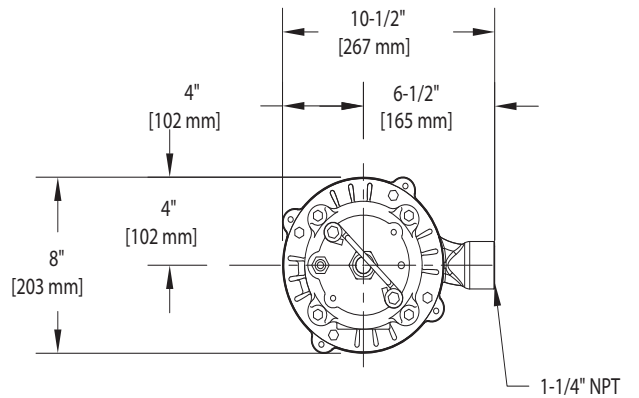

FLYGT ADAPTER - 39-0183

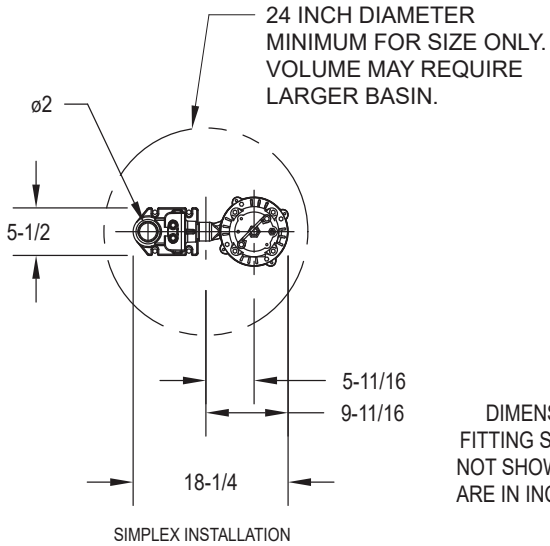

DIMENSIONS ARE BASED ON STD. ANSI FITTING SIZES. CHECK VALVES REQUIRED, NOT SHOWN FOR CLARITY. ALL DIMENSIONS ARE IN INCHES UNLESS OTHERWISE NOTED.

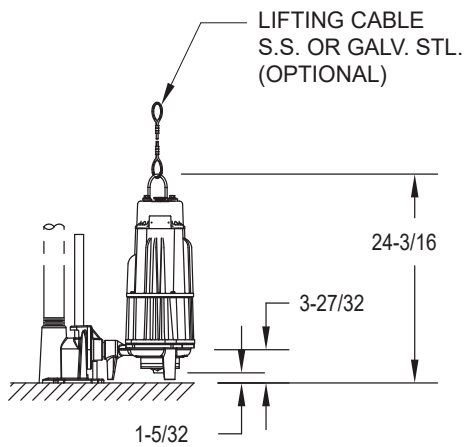

SK3373

LIBERTY ADAPTER - 39-0182

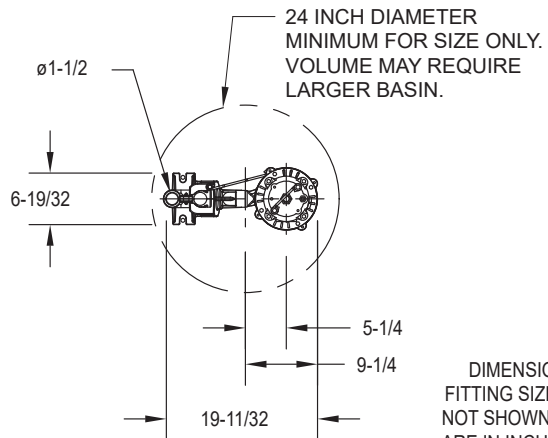

DIMENSIONS ARE BASED ON STD. ANSI FITTING SIZES. CHECK VALVES REQUIRED, NOT SHOWN FOR CLARITY. ALL DIMENSIONS ARE IN INCHES UNLESS OTHERWISE NOTED.

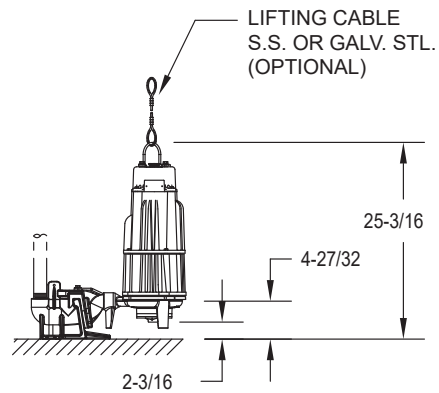

SK3374

Note: For other competitor adapters consult factory

Liberty is a trademark of Liberty Pumps.

**HORIZONTAL DISCHARGE ON A Z-RAIL SYSTEM
39-0137 & 39-0138 Z-Rail**

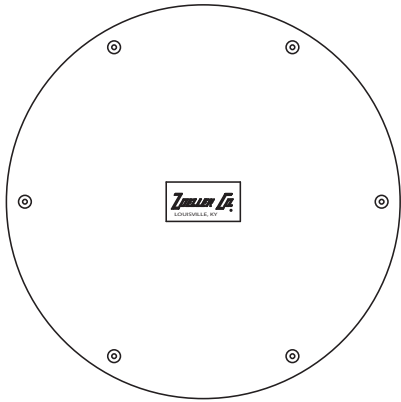

SOLID FIBERGLASS COVER

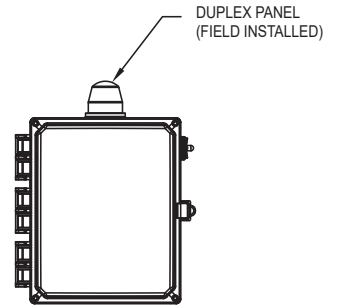
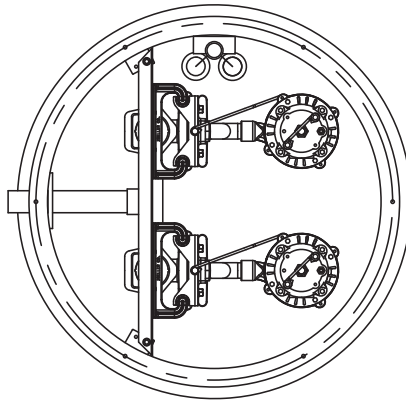

DUPLEX PANEL
(FIELD INSTALLED)

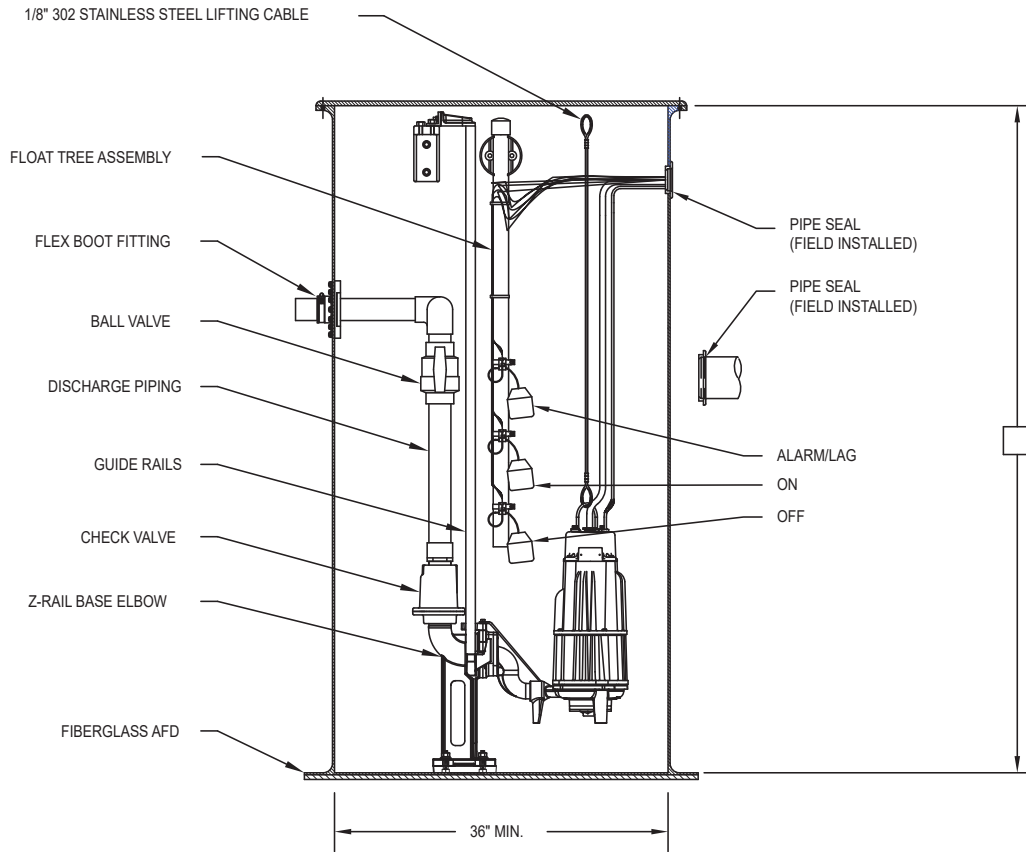

SK3355



MAIL TO: P.O. BOX 16347 • Louisville, KY 40256-0347
SHIP TO: 3649 Cane Run Road • Louisville, KY 40211-1961
Tel: (502) 778-2731 • 1 (800) 928-PUMP

Trusted. Tested. Tough.®

Visit our website:
zoellerpumps.com