

quality . service  
innovation . integrity

# 270 Series



## Features

The "Waste-Mate" series of submersible pumps is designed for use in residential or light commercial dewatering and wastewater applications and can be used to transfer groundwater, effluent or raw sewage. The innovative vortex impeller design reduces the risk of clogging and allows each pump to pass 2" (50 mm) spherical solids. These durable cast iron pumps include a powder coated epoxy finish to prevent corrosion, and are designed to provide great heat dissipation from the motor, ensuring a long service life. As with every Zoeller pump, each one is 100% pressure-tested, submerged and run to ensure quality and reliability for years of trouble-free performance!

- Automatic models include a variable level mechanical pump switch with mounting hardware included.
- For nonautomatic pumps, variable level control systems and containers of various sizes are available for longer cycles.
- Double seal models improve bearing lubrication and aid in the prevention of leaks and damage to seals or bearings during dry run conditions.
- Includes a stainless steel handle for easy installation and removal.
- All models are hermetically sealed to be watertight, dust-tight, and completely submersible.

Reserve Powered Design: For unusual conditions, a reserve safety factor is engineered into the design of every pump.

## Specifications

### Motor Characteristics

Motor	1 HP
Voltage	115 or 230 V
Phase	1 Ph
Hertz	60 Hz
RPM	3450 RPM
Type	Permanent split capacitor
Insulation	Class B
Amps	7.5 - 15.0 Amps

### Pump Characteristics

Operation	Automatic or nonautomatic
Discharge Size	2" NPT
Solids Handling	2" (50 mm) spherical solids
Cord Length	20' (6 m) standard
Cord Type	UL listed, 3-wire neoprene cord and plug
Max Head	29' (8.8 m)
Max Flow Rate	132 GPM (500 LPM)
Max Operating Temp	130° F (54° C)
Cooling	Oil filled
Motor Protection	Auto reset thermal overload

### Materials Characteristics

Cap	Cast iron
Motor Housing	Cast iron
Pump Housing	Cast iron
Base	Engineered plastic or cast iron
Upper Bearing	Sleeve bearing
Lower Bearing	Ball bearing
Mechanical Seals	Carbon and ceramic
Impeller Type	Non-clogging vortex
Impeller	Bronze
Hardware	Stainless steel
Motor Shaft	JIS S45C steel
Gasket	Neoprene



**PUMP COMPANY**

Zoeller Family of Water Solutions™

# 270 Series

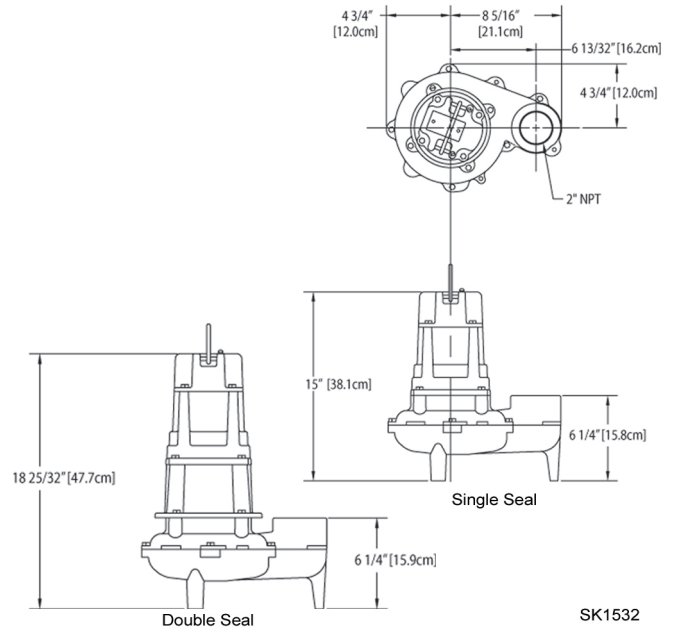
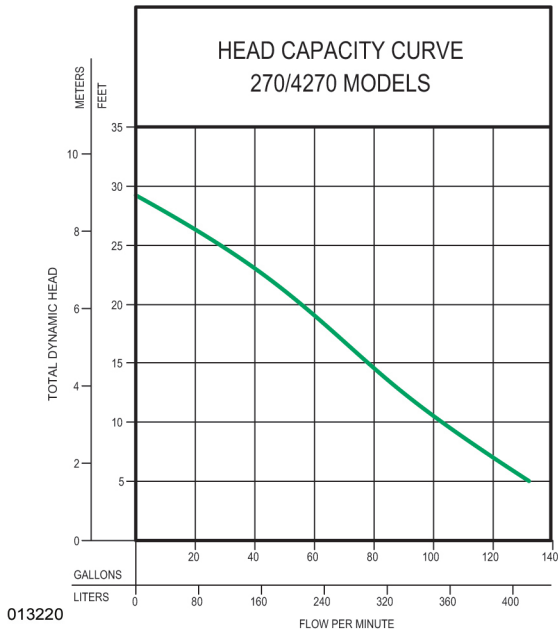

## Model

Model Number	Seal	Mode	Volts	Phase	Amps	HP	Hz	Lbs	Kg
BN270	Single	Auto	115	1	15.0	1	60	49	22
BE270	Single	Auto	230	1	7.5	1	60	73	33
N270	Single	Non	115	1	15.0	1	60	49	22
E270	Single	Non	230	1	7.5	1	60	73	33
N4270	Double	Non	115	1	15.0	1	60	49	22
E4270	Double	Non	230	1	7.5	1	60	73	33

Model 4270 features a cast iron base. BN and BE models include a variable level pump switch.

Additional cord lengths are available in 25' (8 m), 35' (11 m) and 50' (15 m).

**Your Peace of Mind is Our Top Priority®**  
 3649 Cane Run Rd | Louisville, KY 40211 USA  
 1-800-928-7867 | Fax: +1 502-774-3624  
[www.zoeller.com](http://www.zoeller.com)