

FRONT FACE

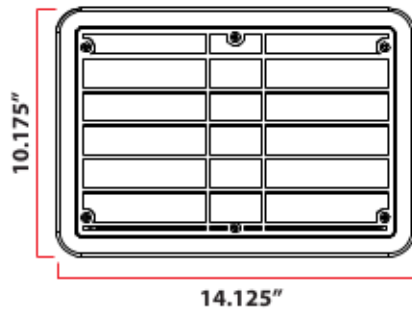

TOP VIEW

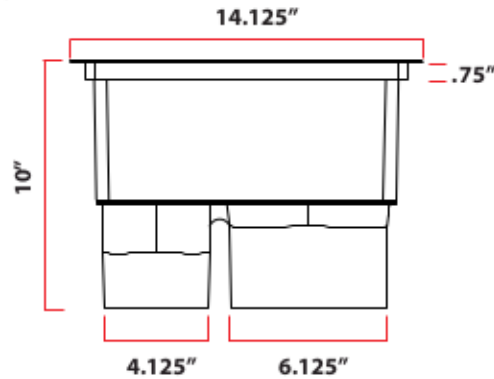

REARVIEW

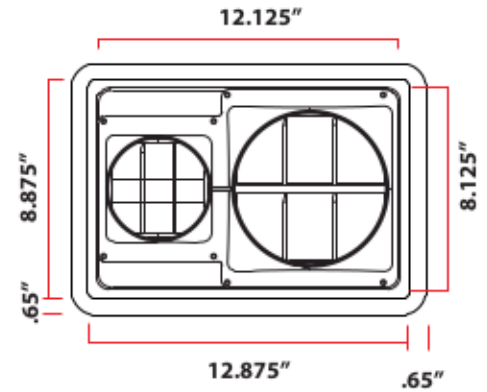

SECTIONAL VIEWS

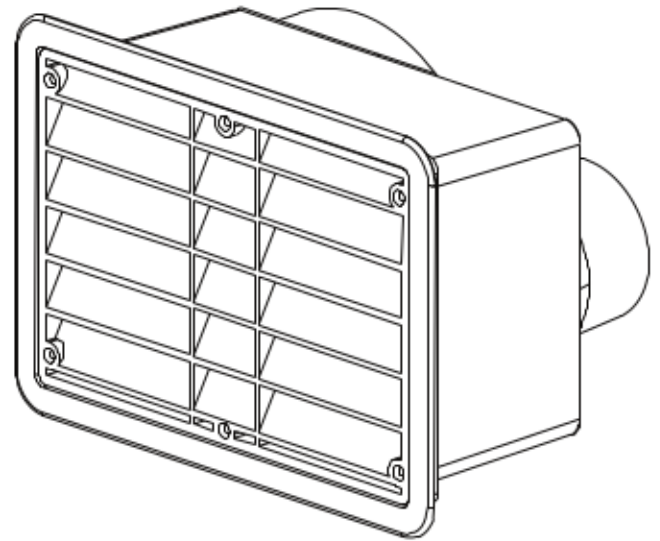
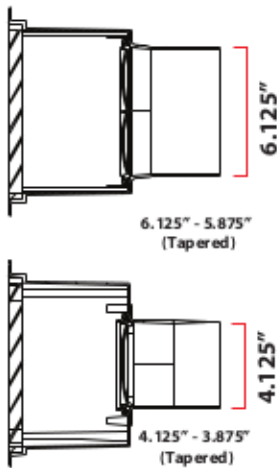

MODEL # DHEB-64R-F PERFORMANCE DATA

FOR USE

- Bathroom exhaust
- Dryer exhaust
- Kitchen hood exhaust
- Fresh air make-up
- Devices that require exterior exhaust or intake

MATERIALS

- Constructed from high temperature plastic polymers.
- Material tested for use on high temperature appliance devices or components. (max sustainable operational temperature at 235°)
- ASTM E84 / UL723 flame spread rating.
- All materials made and fully assembled in the USA

GENERAL INFORMATION

BENEFITS

- Prevents exterior air from entering interior area
- Prevents mold & mildew*
- Eliminates water intrusion**
- Sold assembled
- Single step installation
- Greatly reduces labor cost
- Fits duct sizes up to 4" & 6" diameter ducts
- 100% non corrosive material
- Box cavity designed not to interfere with structural design

FEATURES

- Interior monolithic cavity, positive pitch sidewalls
- Mounted flush with exterior building surface
- Paintable, primer required
- Gravity back draft dampers
- Removable front louver for periodic maintenance and inspections
- Face louver is attached with four stainless steel screws
- Impact resistant
- UV stabilized
- Available in White or Custom colors

* with proper interior environmental conditions

** in accordance with manufacturer recommendations, connected to a ducted system