

Beauty 500T

Features

- Magnifying Makeup Mirror
- Magnification: 5X
- Finish: Polished Chrome or Matte Black
- Wattage: 11W
- Power: Universal 100-240V - Built in Driver
- Rated Life of LED Lights: 20,000 Hours
- Continuously Adjustable Light Range: Cool to Warm
- Brightness Range: Continuous from 610 Lux to 1245 Lux
- Auto-Off After 10 Minutes
- Mounting Back Plate: 3.0" W x 3.0" H



SKU# | Options:

- Beauty 500T CR | Polished Chrome
- Beauty 500T BM | Matte Black

Finishes:

-  Polished Chrome
-  Matte Black

* WS Bath Collections reserves the right to revise dimensions or information on this sheet without notice

Collection Beauty	Model Beauty 500T	Dimensions Metric <i>1 inch = 2.54 cm</i> <i>1 inch = 25.4 mm</i>	 1051 Lea Drive - Collegeville, PA 19426 Tel. 215 513 9400 - Fax 610 831 0215 www.ws bathcollections.com - info@ws bathcollections.com
-------------------------------	-------------------------------	---	---

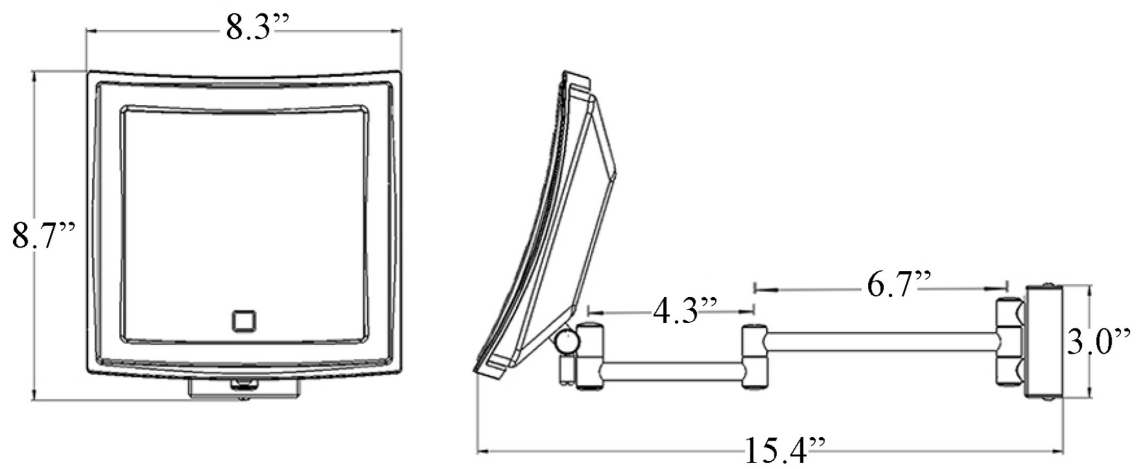

Collection
Dgcw{

Model |
Dgcw{ "722V

Dimensions Metric
1 inch = 2.54 cm
1 inch = 25.4 mm

WS[®]
BATH
COLLECTIONS

1051 Lea Drive - Collegeville, PA 19426
Tel. 215 513 9400 - Fax 610 831 0215
www.ws bathcollections.com - info@ws bathcollections.com