

FEATURES

- Stainless steel trim to match Wolf transitional products.
- Ceran glass-ceramic surface for scratch resistance and easy cleaning.
- Induction elements heat iron and other magnetic cookware instantly, while cooktop surface stays cool.
- Cookware sensing—elements will not be energized without an induction-compatible pan on the surface.
- Bridge zone connects two elements front-to-back or side-to-side, or all four to create a 17" x 17" cooking area.
- Wolf exclusive induction elements sense pan size to focus power for optimum performance.
- Boost mode boosts power by diverting power from an adjacent element.
- Wolf exclusive melt setting for gentle heat, and true simmer setting prevents scorching.
- Touch controls display an intuitive power scale for precise control.
- Indicators including boost mode, illuminate on the control panel.
- Control panel lock.
- Independent timer up to 99 minutes.



MODEL	
Transitional	CI365T

INDUCTION COOKING

In induction cooking, the electricity flows through a coil to produce a magnetic field under the glass-ceramic surface. When an induction-compatible pan is placed on the cooktop, currents are induced in the pan and instant heat is generated. Cookware made of magnetic materials, such as cast iron or magnetic stainless steel is required for induction cooking.

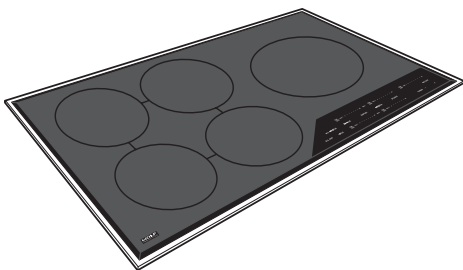

Model CI365T

SPECIFICATIONS

PRODUCT

Dimensions 36"W x 2"H x 21"D
Weight 61 lb

ELECTRICAL

Supply 3-wire, 240/208 VAC, 60 Hz
Service 50 amp circuit
Conduit 4' flexible

DIAMETER

Element 10 1/2", (4) 8"

ELEMENT RATING

Large 2600 / 3700 boost
Medium (4) 2100 / 3000 boost

Specifications are subject to change without notice. Visit wolfappliance.com/specs for the most up-to-date information.

Dimensions may vary $\pm 1/8"$ (3). Dimensions in parentheses are millimeters unless otherwise specified.

DIMENSIONS

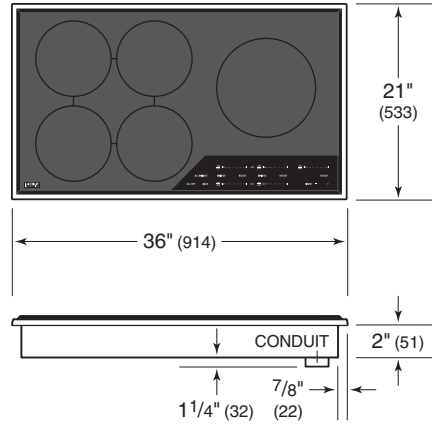

INSTALLATION

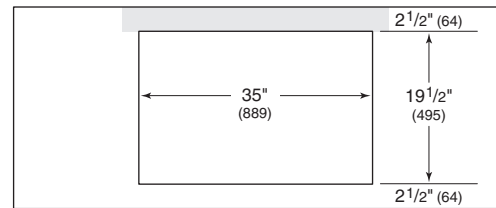

COUNTERTOP CUT-OUT

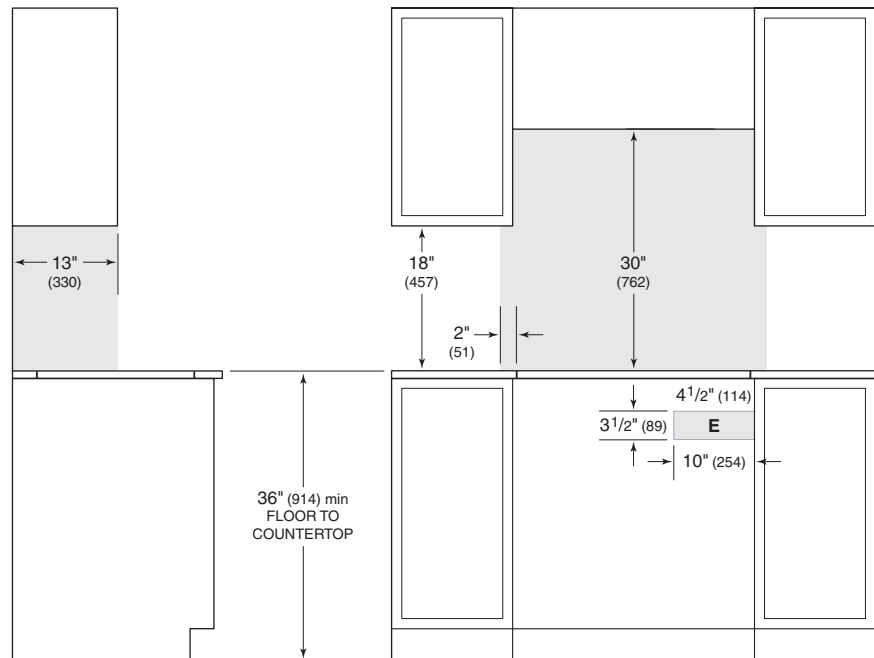

SIDE VIEW

FRONT VIEW

NOTE: Shaded area above countertop indicates minimum clearance to combustible surfaces, combustible materials cannot be located within this area.
Electrical supply location only applies to installations with built-in oven.