



Installation Manual

**WM-1500HTD WM-1500HTD-TE
WM-2500HTD WM-2500HTD-TE**



By *Vinotemp*
www.vinotemp.com

Tel: (310) 886-3332
Fax: (310) 886-3310
Email: info@vinotemp.com

Read and save these instructions

Important Safety Information

- DO NOT PLUG IN UNTIL 24 HOURS AFTER DELIVERY.
- DO NOT USE A GROUND FAULT INTERRUPTER (GFI).
- A DEDICATED 20 AMP CIRCUIT IS REQUIRED.

WARNING



To avoid the risk of electrical shock, property damage, personal injury or death:

- The power cord must be plugged into a 3-prong grounding-type wall receptacle, grounded in accordance with the National Electrical Code, ANSI/NFPA 70 - latest edition and local codes and ordinances.
- It is the personal responsibility of the consumer to have a proper 3-prong wall receptacle installed by a qualified electrician.
- DO NOT, UNDER ANY CIRCUMSTANCES, REMOVE THE POWER CORD GROUNDING PRONG.
- A separate adequately fused and grounded circuit should be available for this appliance.
- Do not remove any grounding wires from individual components while servicing, unless the component is to be removed and replaced. *It is extremely important to replace all grounding wires when components are replaced.*

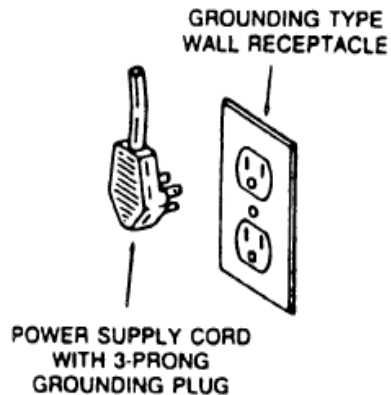

WARNING



ELECTRIC SHOCK HAZARD

- Disconnect electric supply from appliance before servicing.
- Replace all panels before operating.
- Failure to do so could result in death or electrical shock.

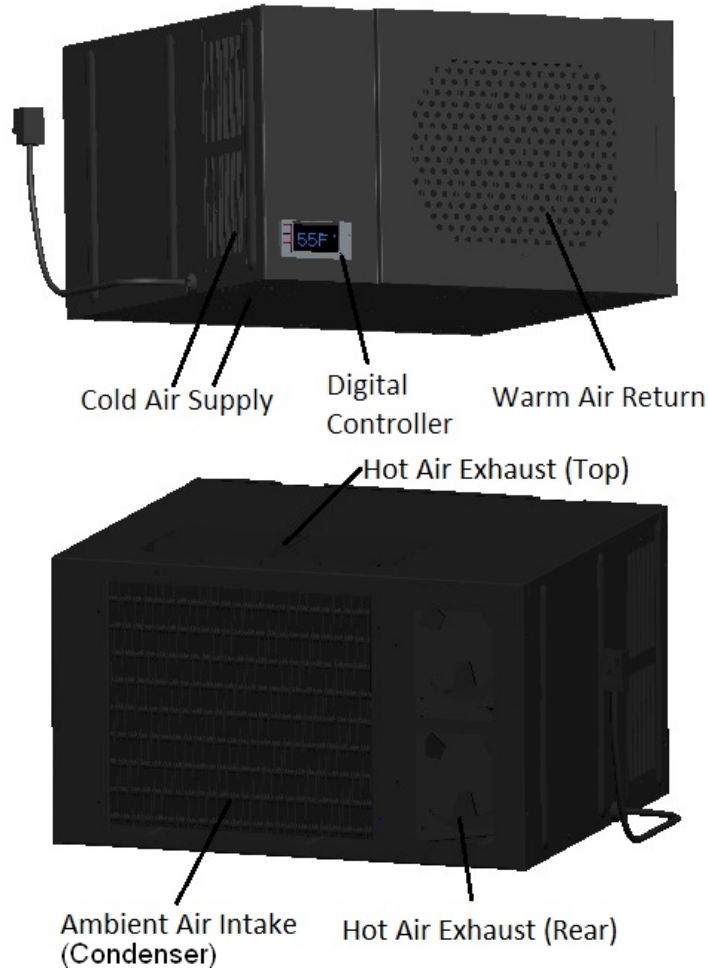

The specifications and dimensions are listed as follows:

Model	Exhaust	CFM	Cabinet Size (cu ft)	Electrical	Weight (lb)
WM-1500htd	Rear Exhaust	120	90	115V/60Hz/4A	55
WM-1500htd-te	Top Exhaust	120	90	115V/60Hz/4A	55
WM-2500htd	Rear Exhaust	180	200	115V/60Hz/5A	60
WM-2500htd-te	Top Exhaust	180	200	115V/60Hz/5A	60

NOTES:

- The voltage, frequency and current are specified on the label, on the cooling unit.
- The rated capacity is determined using the cabinet and ambient temperatures of 55°F and 75°F, with R13 interior and R19 exterior insulations. A lower

cabinet temperature, or higher ambient temperature and less insulation will cause the capacity to reduce and may not maintain a temperature of 55°F.

- In order for the unit to operate properly, the ambient temperatures for WM-1500HTD should not be higher than 78°F or lower than 50°F.
- In order for the unit to operate properly, the ambient temperatures for WM-2500HTD should not be higher than 95°F or lower than 50°F.
- Mounting brackets, screws, gaskets and other sealing materials are not included.
- Do not install any ducts onto the supply, return, intake or exhaust.
- Because of potential safety hazards that may occur under certain conditions, we strongly recommend against the use of an extension cord. However, if you still elect to use an extension cord, it is absolutely necessary that it be a UL LISTED 3-wire grounding type appliance extension cord. The cord should have a 3-blade grounding plug, and a 3-slot receptacle that will plug into the appliance. The marked rating of the extension cord should be 115 V, 15 A.

1. Cabinet Location

- Place the wine cabinet in a properly ventilated location. Otherwise, heat exhaust from the cooling unit will build up, and the unit will not operate properly.
- The exhaust area must not be in an enclosed space, and must be in an area with ventilation. The ambient temperatures should not be higher than 78°F or lower than 50°F for a WM-1500HTD unit. The ambient temperatures for a WM-2500HTD unit should not be higher than 95°F or lower than 50°F.

1) Rear Exhaust Location

- Leave min 6" clearance from the rear to the wall.
- Leave min 12" clearance from the top to the ceiling.
- Leave min 6" clearance from the left and right sides.

2) Front Exhaust Location

- Leave min 6" clearance from the front, if the left and right sides are unobstructed.
- Or, leave min 36" clearance from the front, if the left and right sides obstructed.

3) Top Exhaust Location

- Leave min 12" from the top to the ceiling.
- Leave min 2" clearance from the rear to the wall.
- Leave min 2" clearance from the left and right sides.

4) Side Exhaust Location

- Leave min 6" clearance from the left or right side to the wall.
- Leave min 12" clearance from the top to the ceiling.

2. Cooling Unit Installation

- The cooling unit produces cooling that is supplied into the cabinet, meanwhile it also generates heat that must be exhausted outside of the cabinet. So the cold-air supply with return-air intake, and hot-air exhaust with ambient-air side must be separated and sealed. Foam tape gasket may be used to seal them. The cooling unit must intake adequate fresh ambient-air to work properly. The ambient-air intake and hot-air exhaust must not be short-circulated. A piece of wood may be used to separate them.
- Cut a rectangular inside opening at the rear of the cabinet, with 1/4" clearance inwards toward the width and height of the cooling unit. Without going through, leave 1/2" lip inside the wall to place the gaskets (see Fig. 2.1 & 2.2).
- If top exhaust installation, cut another rectangular opening at the top of the cabinet to the length and width of the top exhaust (see Fig. 2.1 & 2.3).
- Install 2 pieces of 1/4" ID wood thread inserts at the ceiling (see Fig. 2.1 & 2.4).
- Place the gaskets (1/2" foam tape) on the gasket lips (see Fig. 2.1 & 2.5).
- If top exhaust installation, place another gasket along the top exhaust at the top of the cooling unit (see Fig. 2.1 & 2.6).
- Move the cooling unit towards the mounting sides and push to press the gaskets into place.
- Use 2 mounting brackets and 1/4" screws with 7/16" wrench to secure the cooling unit (see Fig. 2.7).
- Install the front cover using two #8 screws on each side (see Fig. 2.8).
- Install the wall grille at the back of the cabinet (see Fig. 2.11).
- Plug the cooling unit in the cabinet receptacle.
- Plug in the wine cabinet.

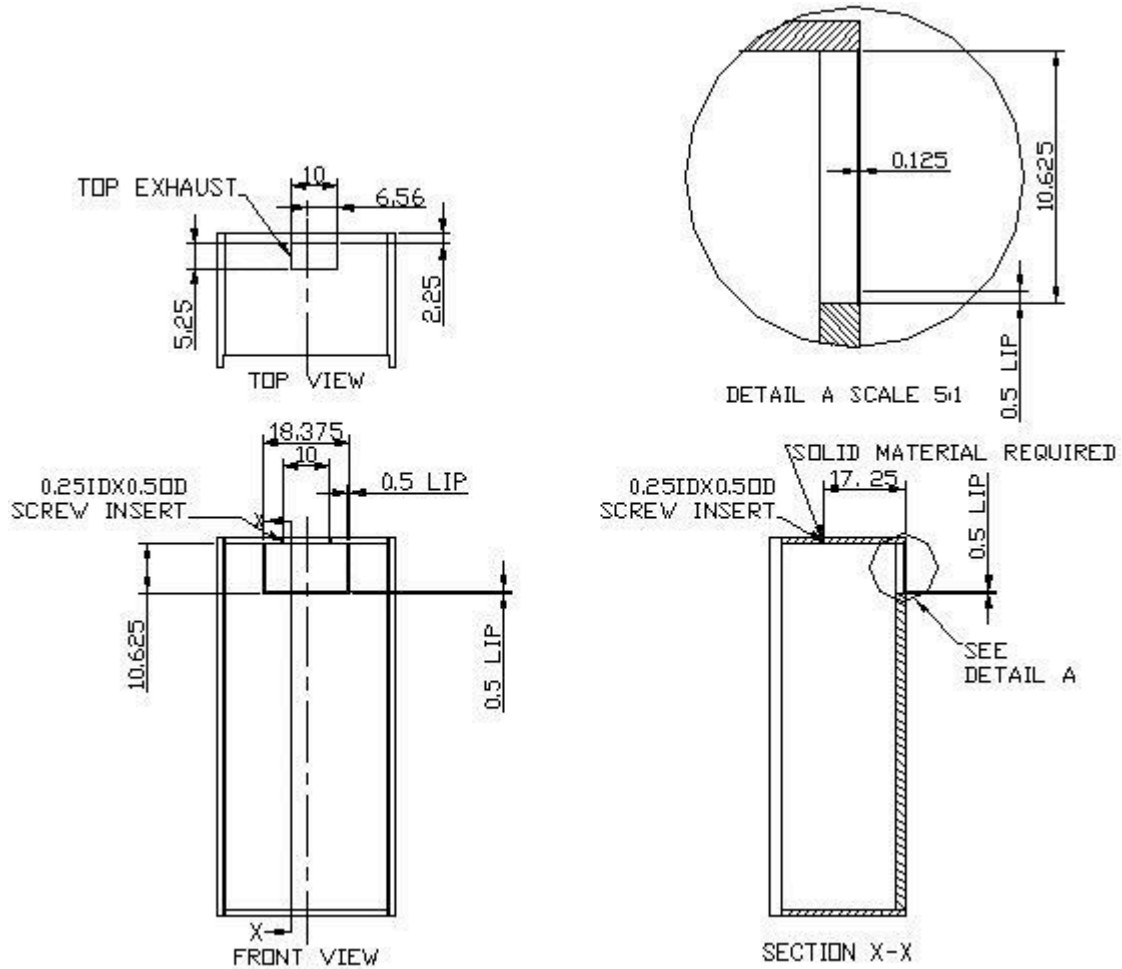

Fig. 2.1 CUTOUT AND HOLE DIMENSIONS

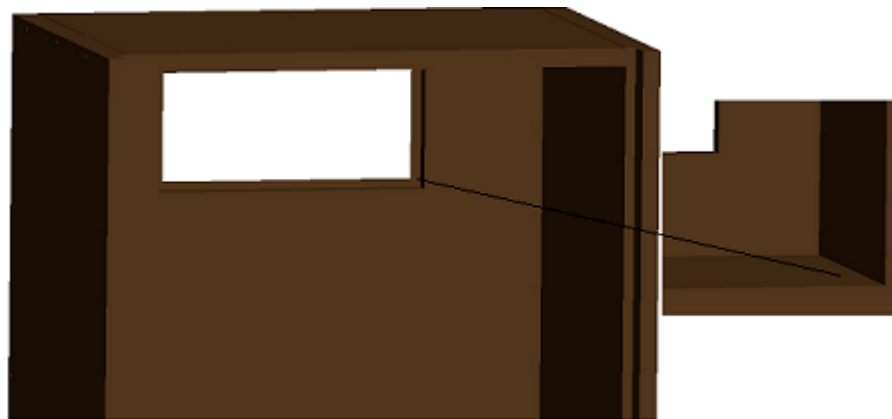

Fig. 2.2 REAR EXHAUST CUTOUT

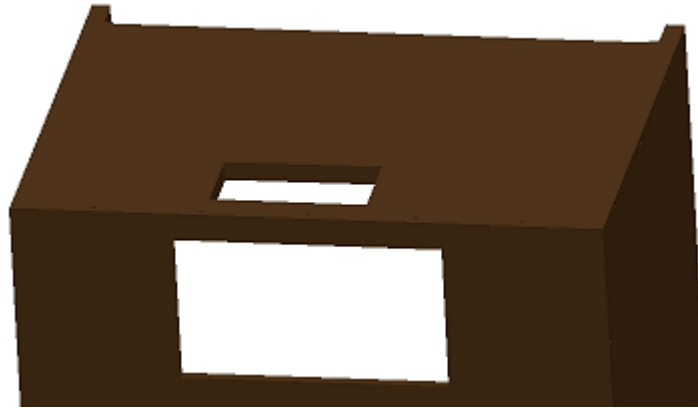

Fig. 2.3 TOP EXHAUST CUTOUTS

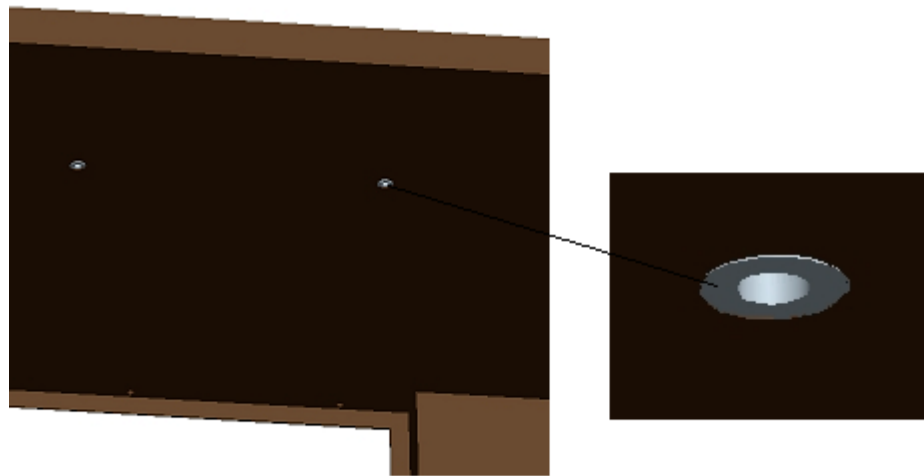

Fig. 2.4 MOUNTING SCREW INSERTS

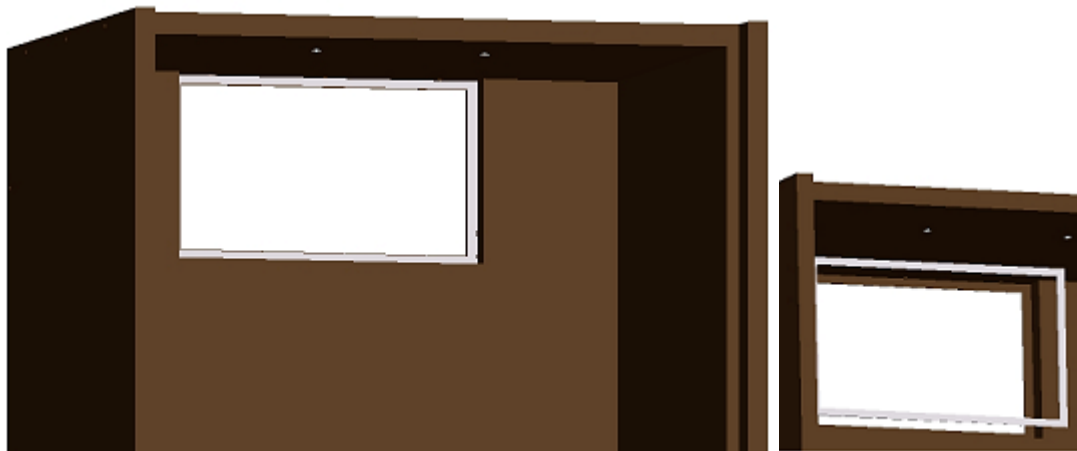

Fig. 2.5 REAR GASKETS

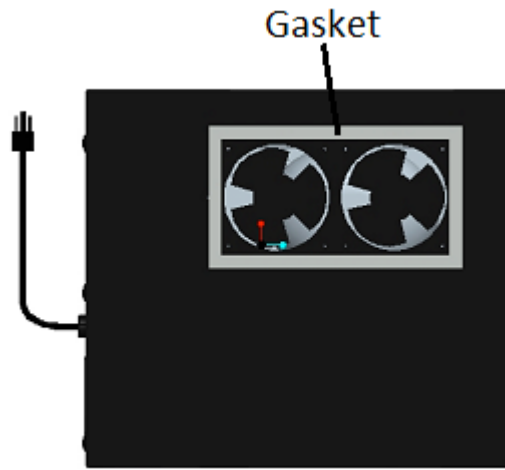

Fig. 2.6 TOP EXHAUST GASKETS

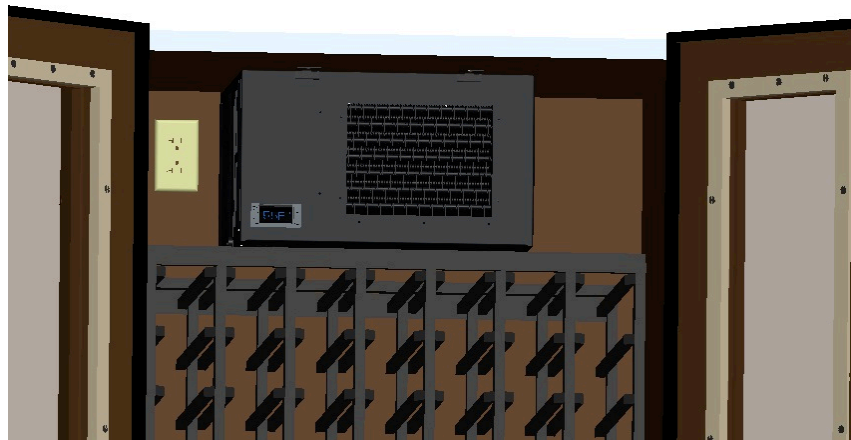
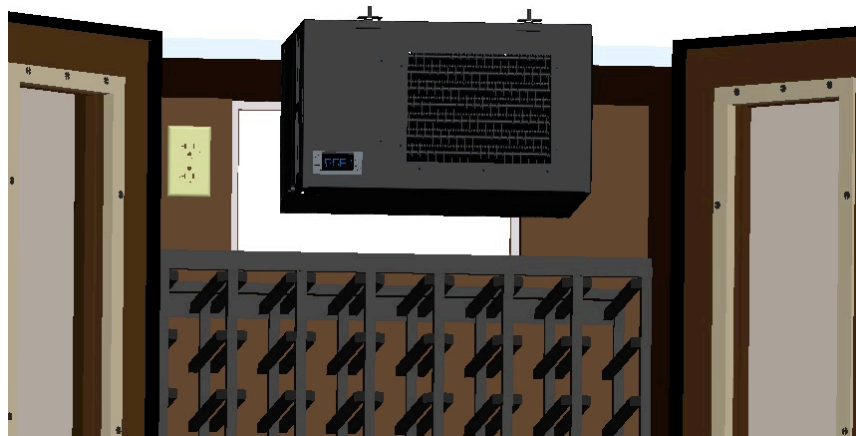

Fig. 2.7 MOUNTING COOLING UNIT

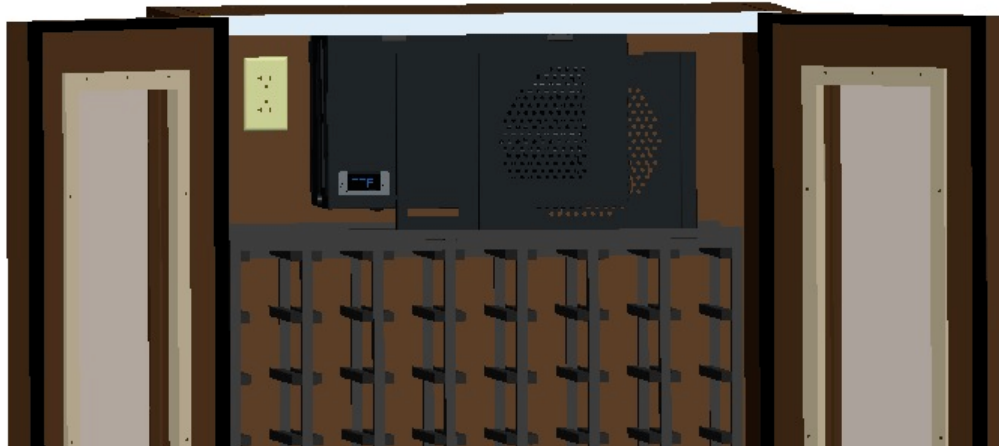

Fig. 2.8 MOUNTING FRONT COVER



Fig. 2.9 COOLING UNIT MOUNTED (REAR EXHAUST)

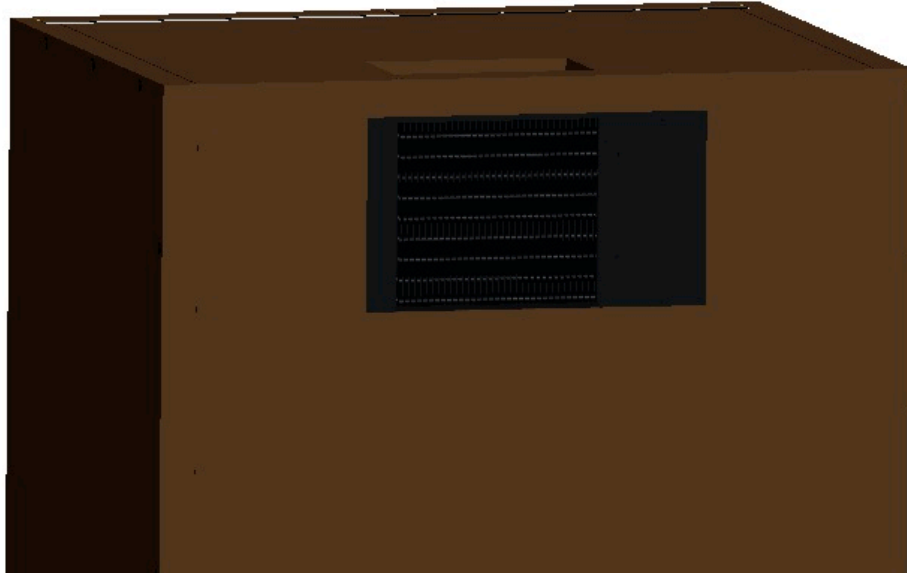

Fig. 2.10 COOLING UNIT MOUNTED (TOP EXHAUST)



Fig. 2.11 INSTALLING WALL GRILLE