

NOTICE
 This drawing embodies a CONFIDENTIAL proprietary design originated by WILLIAMS FURNACE CO., and all design, manufacturing, reproduction, use and sale rights regarding the same are expressly reserved. It is submitted under a confidential relationship for a specific purpose, and the recipient agrees by accepting this drawing not to supply or disclose any information regarding it to any unauthorized person, or to incorporate in other projects any special features unique to this design. All patent rights hereto are expressly reserved.

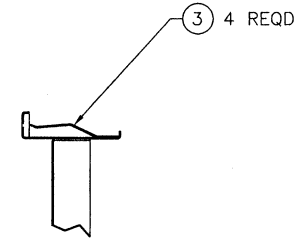

DETAIL A
 SCALE: NONE

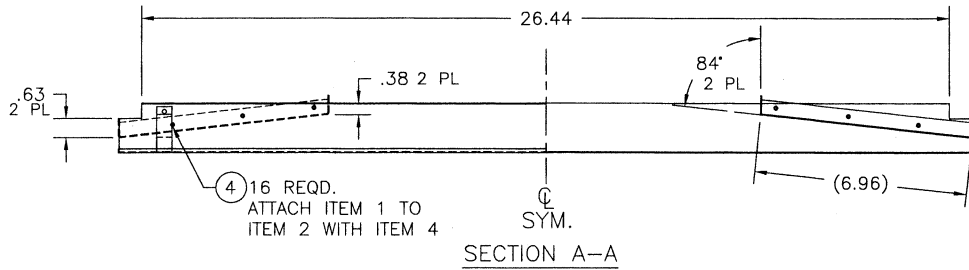
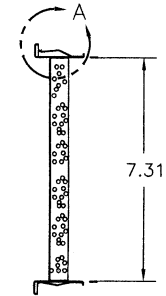
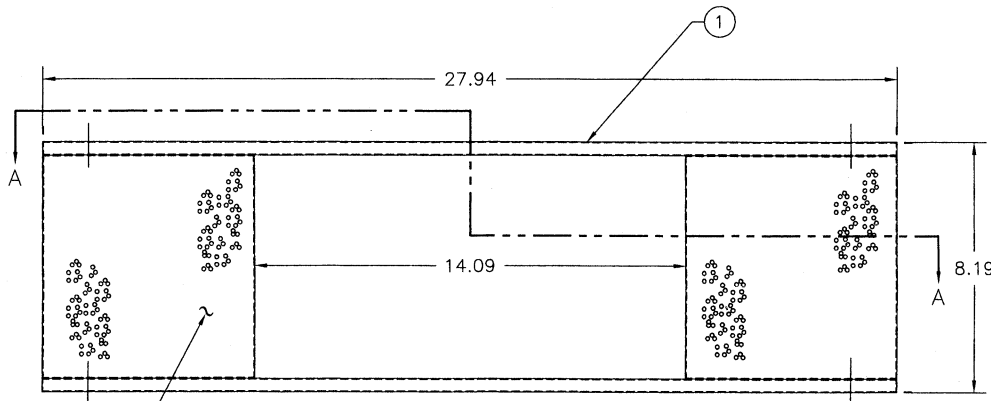

4	P130900	16	RIVET - .125 DIA.
3	K1171-6002	4	CLIP, HEARTH
2	K000461	2	REFLECTOR
1	K000201	2	HEARTH
ITEM	PART NO.	NO. REQD	DESCRIPTION
DWN:	J.A.	APP:	DATE: 9/10/96
WILLIAMS FURNACE CO. 225 ACACIA ST. COLTON, CALIFORNIA 92324 • USA			TOLERANCES UNLESS OTHERWISE SPECIFIED: .XX= ± .030 .XXX= ± .015 ANGLES= ± 3'
			SCALE: 1:4 DO NOT SCALE DWG.
TITLE HEARTH ASSEMBLY (500 CONSOLE WITH LOGS)			NEXT ASSY:
PART NO.		SIZE	DWG. NO.
		B	K000463
			REV A

A	REVISED ITEM 2; REFLECTOR WAS REFLECTOR, CHROME	T.D.	E.M. 2239	5-19-98
~	RELEASE TO PRODUCTION	J.A.	ECO 2118	9/10/96
LTR.	REVISION	DWN.	APP.	DATE