

## For Residential and Commercial Applications

Job Name \_\_\_\_\_

Contractor \_\_\_\_\_

Job Location \_\_\_\_\_

Approval \_\_\_\_\_

Engineer \_\_\_\_\_

Contractor's P.O. No. \_\_\_\_\_

Approval \_\_\_\_\_

Representative \_\_\_\_\_

# LEAD FREE\*

## Series LF25AUB-Z3 Water Pressure Reducing Valves\*\*

Sizes: 1/2" – 2" (15 – 50mm)

Series LF25AUB-Z3 Water Pressure Reducing Valves are designed to reduce incoming water pressure to a sensible level to protect plumbing system components and reduce water consumption. This series is suitable for water supply pressures up to 300psi (20.7 bar) and may be adjusted from 25 – 75psi (172 – 517 kPa). The LF25AUB-Z3 features Lead Free\* construction to comply with Lead Free\* installation requirements. The standard setting is 50psi (345 kPa). All parts are quickly and easily serviceable without removing the valve from the line. The standard bypass feature permits the flow of water back through the valve into the main when pressures, due to thermal expansion on the outlet side of the valve, exceed the pressure in the main supply.

### Features

- Standard construction includes Z3 sealed spring cage and stainless steel corrosion resistant adjusting & cage screws for accessible outdoor or pit installations
- Union inlet connection
- Integral stainless steel strainer
- Replaceable seat module
- Lead Free\* brass body construction
- Serviceable in line
- Bypass feature controls thermal expansion pressure\*\*\*
- High temperature resistant reinforced diaphragm for hot water

### Models

LF25AUB-Z3	NPT threaded female union inlet x NPT female outlet
LF25AUB-S-Z3	Solder union inlet x NPT female outlet
LF25AUB-DU-Z3	Double Union – NPT threaded union female inlet and outlet
LF25AUB-S-DU-Z3	Double Union – Solder union inlet and outlet
LF25AUB-DU-THDxPEX-Z3	Double Union – NPT threaded female inlet and PEX union outlet
LF25AUB-DU-LF-Z3	Double union body less fittings (3/4", 1", 1 1/4")
LF25AUB-QC-Z3	Single Union – Quick-Connect union inlet (1/2", 3/4", 1")
LF25AUB-DU-QC-Z3	Double Union – Quick-Connect inlet and outlet (1/2", 3/4", 1")

### Specifications

A Water Pressure Reducing Valve with integral strainer shall be installed in the water service pipe near its entrance to the building where supply main pressure exceeds 60psi (413 kPa) to reduce it to 50psi (345 kPa) or lower. The water pressure reducing valve shall be constructed using Lead Free\* materials. Lead Free\* regulators shall comply with state codes and standards, where applicable, requiring reduced lead content. The valve shall feature a Lead Free\* brass body suitable for water supply pressures up to 300psi (20.7 bar). Provision shall be made to permit the bypass flow of water back through the valve into the main when pressures, due to thermal expansion on the outlet side of the valve, exceed the pressure in the main supply. Water Pressure Reducing Valve with built-in bypass check valves will be acceptable. Approved valve shall be listed to ASSE 1003 and IAPMO and certified to CSA B356. Valve shall be a Watts Series LF25AUB-Z3.\*\*

LF25AUB-Z3

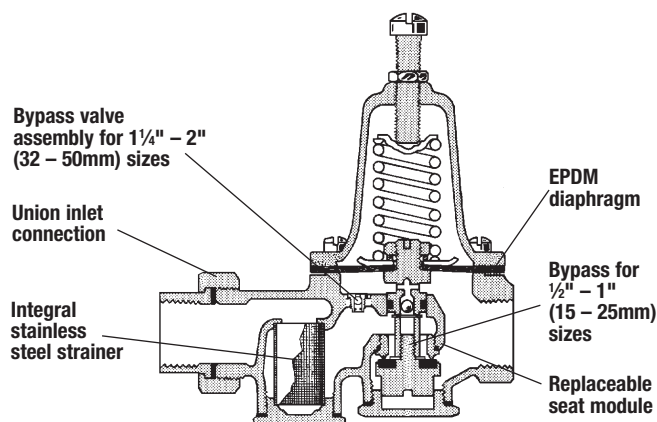

\*The wetted surface of this product contacted by consumable water contains less than 0.25% of lead by weight.

\*\*A water saving test program concluded that reducing the supply pressure from 80-50psi (551-345 kPa) resulted in a water savings of 30%.

\*\*\*The bypass feature will not prevent the pressure relief valve from opening on the hot water supply system with pressure above 150psi (10.3 bar).

Watts product specifications in U.S. customary units and metric are approximate and are provided for reference only. For precise measurements, please contact Watts Technical Service. Watts reserves the right to change or modify product design, construction, specifications, or materials without prior notice and without incurring any obligation to make such changes and modifications on Watts products previously or subsequently sold.

## Materials

Body: Lead Free\* brass  
 Seat: 1/2"-1" (15-25mm) Replaceable engineered polymer (10% glass filled Noryl®)  
 1 1/4"-2" (32-50mm) Replaceable stainless steel  
 Integral Strainer: Stainless steel  
 Diaphragm: Reinforced EPDM  
 Valve Disc: EPDM

**Note:** for LP models where application temperatures exceed 160°F (71°C), but not over 180°F (82°C), a Teflon® protector should be added to sizes 1 1/4"-2" (32-50mm).

## Pressure – Temperature

Temperature Range: 33°F – 160°F (0.5°C – 71°C)  
 Maximum Working Pressure: 300psi (20.7 bar)  
 Adjustable Reduced Pressure Range: 25-75psi (172 – 517 kPa)  
 Standard Reduced Pressure Setting: 50psi (345 kPa)

## Options

### Add Suffix

G Gauge tapping, 1/8" (3mm)  
 GG Gauge tapping and 160psi (11 bar) gauge  
 HP High pressure range 75-125psi (5.2 – 8.6 bar)  
 LP Low pressure range 10-35psi (69 – 241 kPa)  
 Z7 400psi (27.6 bar) initial pressure, 1/2" (20mm) models only

Noryl® is a registered trademark of SABIC Innovative Plastics™  
 Teflon® is a registered trademark of the E. I. du Pont de Nemours & Company.

## Dimensions – Weights

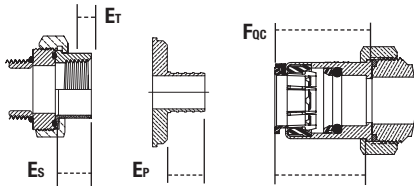

A - LF25AUB-Z3  
 A<sub>1</sub> - LF25AUB-S-Z3  
 A<sub>2</sub> - LF25AUB-DU-LF-Z3  
 B - LF25AUB-DU-Z3  
 B<sub>1</sub> - LF25AUB-S-DU-Z3  
 B<sub>2</sub> - LF25AUB-DU-THDXPEX-Z3  
 E<sub>T</sub> - NPT Engagement for tight joint  
 E<sub>S</sub> - Female sweat socket depth  
 E<sub>P</sub> - PEX end connection  
 F<sub>OC</sub> - Quick-Connect union

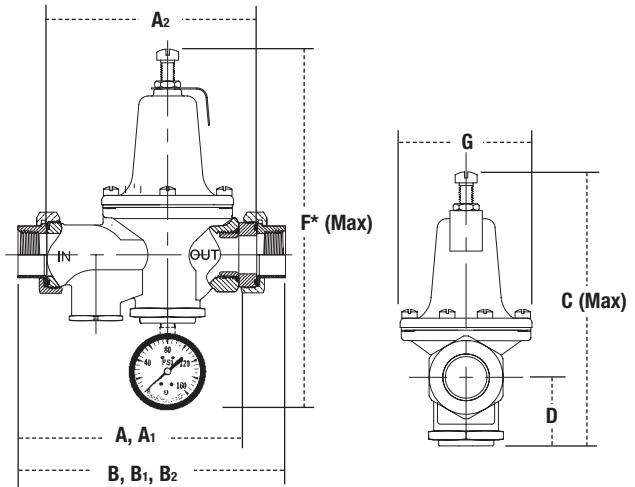

SIZE (DN)		DIMENSIONS													
		A		A <sub>1</sub>		A <sub>2</sub>		B		B <sub>1</sub>		B <sub>2</sub>		C	
in.	mm	in.	mm	in.	mm	in.	mm	in.	mm	in.	mm	in.	mm	in.	mm
1/2	15	5 5/8	137	5 5/16	135	5 3/16	132	6 7/16	164	6 3/8	162	-	-	7	178
3/4	20	5 5/16	135	5 1/2	140	5 1/4	133	6 1/2	165	6 3/8	175	6 3/4	171	7	178
1	25	6	152	6 1/4	159	5 7/8	149	7 3/8	187	7 13/16	198	7 11/16	195	8	203
1 1/4	32	8 3/4	222	8 15/16	227	8 1/4	210	10 3/4	273	11	279	-	-	9	229
1 1/2	40	8 3/4	222	9	229	8 1/4	210	10 3/4	273	11 3/16	284	-	-	9 1/2	241
2	50	9 1/4	235	10	254	8 3/4	222	11 5/16	287	12 11/16	322	-	-	11 1/4	286

SIZE (DN)		DIMENSIONS							WEIGHT						
		F*		G		E <sub>T</sub>		E <sub>S</sub>		E <sub>P</sub>		F <sub>OC</sub>		lbs.	kg.
in.	mm	in.	mm	in.	mm	in.	mm	in.	mm	in.	mm	in.	mm		
1 1/2	38	9 7/16	240	3 3/8	79	1/2	13	1/2	13	-	-	1 1/2	38	3.5	1.6
1 1/2	38	9 7/16	240	3 3/8	79	1/2	13	3/4	19	5/8	16	1 11/16	42	3.5	1.6
1 3/4	44	10 7/16	266	3 3/8	92	5/8	16	1 5/16	23	1 3/16	21	1 3/4	45	6.5	3.0
2 1/8	54	11 7/16	291	3 5/8	92	5/8	16	1	25	-	-	-	-	10	4.5
2 3/8	60	11 15/16	304	4 1/16	103	5/8	16	1 1/16	28	-	-	-	-	10	4.5
3/4	83	13 11/16	348	4 3/4	121	5/8	16	1 5/16	34	-	-	-	-	15	6.8

\* Dimension includes optional gauge



A Watts Water Technologies Company



USA: Tel. (978) 688-1811 • Fax: (978) 794-1848 • www.watts.com  
 Canada: Tel. (905) 332-4090 • Fax: (905) 332-7068 • www.wattscanada.ca



Meets requirements of ASSE Standard 1003; ANSI A112.26.2; CSA Standard B356; Southern Standard Plumbing Code and listed by IAPMO. Military Standard MIL-V-18146B Type I.

## Capacity

Sizes: 1/2", 3/4", 1", 1 1/4", 1 1/2", 2"  
 (15, 20, 25, 32, 40, 50mm)

