

# AIR SWITCH INSTALLATION

Contemporary Model # 3010

Traditional Model # 4010

## BEFORE YOU BEGIN YOUR INSTALLATION:



Turn off water supply.

### REQUIRED TOOLS:



1. Adjustable Wrench



2. Phillips Screwdriver

### PARTS INCLUDED:

USM1375

Undersink Mounting Hardware  
(1-1/4")

**1.**

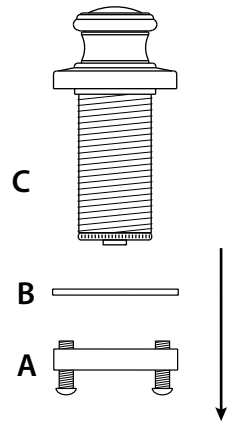

Remove clamp nut (A) and washer (B) from threaded shroud (C).

**2.**

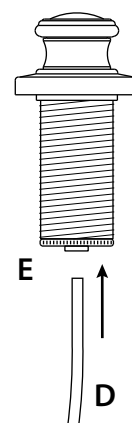

Slide clear tubing (D) into tube fitting (E) at bottom of air switch.

**3.**

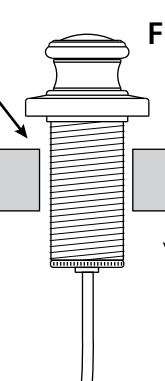

Fit air switch (F) through 1-1/2" hole on counter or sink. (No plumbers putty is required. O-ring seals base).

**4.**

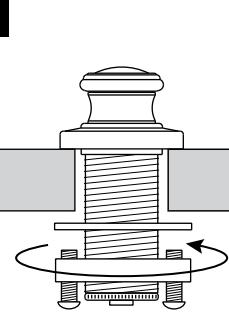

Slide washer and thread the clamp nut onto threaded shroud. Tighten nut snug to underside of sink or counter.

**5.**

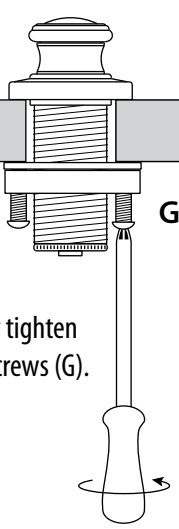

Securely tighten clamp screws (G).

**6.**

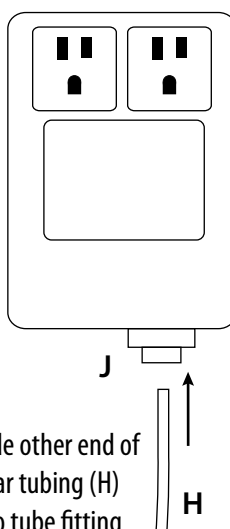

Slide other end of clear tubing (H) into tube fitting at bottom of control box (J).

**7.**

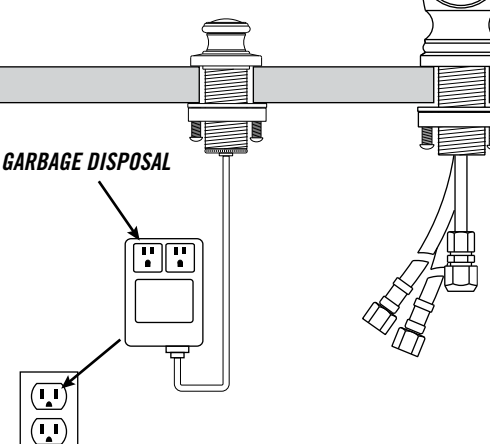

Plug control box into undersink electrical outlet. Garbage disposal can be plugged into either dual outlet.