

CATALOG NUMBER	TYPE
PROJECT	

KALEIDOSCOPE COLLECTION

QUICK CONNECT™ pendants- PRISMA

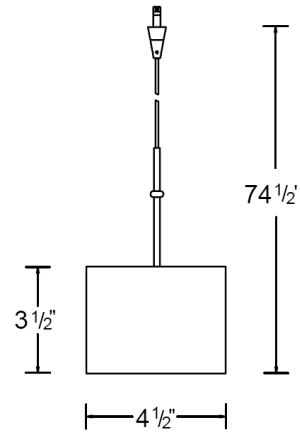

Ordering Matrix		
Model	Glass	Socket Set Finish
QP940	CL-Clear	BN – Brushed Nickel CH – Chrome DB – Dark Bronze

Example (Model-Glass/Socket Set Finish) : **QP940-CL/BN**

Product Details	
Description:	Complete set includes crystal glass shade, socket set and lamp for use with all WAC QUICK CONNECT™ systems. May also be compatible with other manufacturers quick connect systems. Consult WAC for system compatibility information.
Materials:	QP940-CL/BN consists of three parts: (1) G940-CL Clear glass shade (1) QP-902-BN Pendant socket set (1) BP-50 Xenon Bi-pin lamp (included)
Socket:	Include 6' of braided cable and hang-straight tube.
Shade:	Optical crystals are transformed into a variety of shapes and styles to deploy a broad range of exciting lighting effects for residential, retail and hospitality displays. The glass shade measures as follows: 3 1/2" H x 4 1/2" Ø
Wattage:	12v 50w max.
Finish:	CL/BN - Clear pendant and Brushed Nickel socket CL/CH - Clear pendant and Chrome socket CL/DB - Clear pendant and Dark Bronze socket
Listing:	UL & CUL Listed.

Specification Features
<ul style="list-style-type: none"> ● QP940 requires proper QUICK CONNECT™ adapter to use with WAC's low voltage rail and track systems (DUORAIL™, SOLORAIL™ and Linear track), line voltage track systems, (FLEXRAIL1™ and 120v track) and monopoint and multipoint canopies. ● Complete set should include glass shade (G940), socket set and lamp ● 6' long socket set cable, field cuttable ● Socket set finishes include Brushed Nickel (BN), Chrome (CH) & Dark Bronze (DB) ● 5 year product warranty.