

# Installation Instructions: Track Mount- Metal Halide Wall Wash Fixture

## Model: HTK-765-70E

### CAUTION:

For Use with WAC "H" track systems. Fixture may also be used on other manufacturers brand of track (consult factory for compatibility).

CAUTION – To reduce the risk of a burn during relamping, remove from the track before relamping.

Read all instructions before installing.

### Installing on Track:

1. Note the track has a groove running it's length to indicate polarity.
2. Insert adapter into track slot and rotate it 90° The embossed arrow on the adapter should point to the grooved side of the track.
3. Push up and turn the locking tab into the lock position.
4. Removal is the reverse procedure. Tracks may be positioned anywhere along the track length.

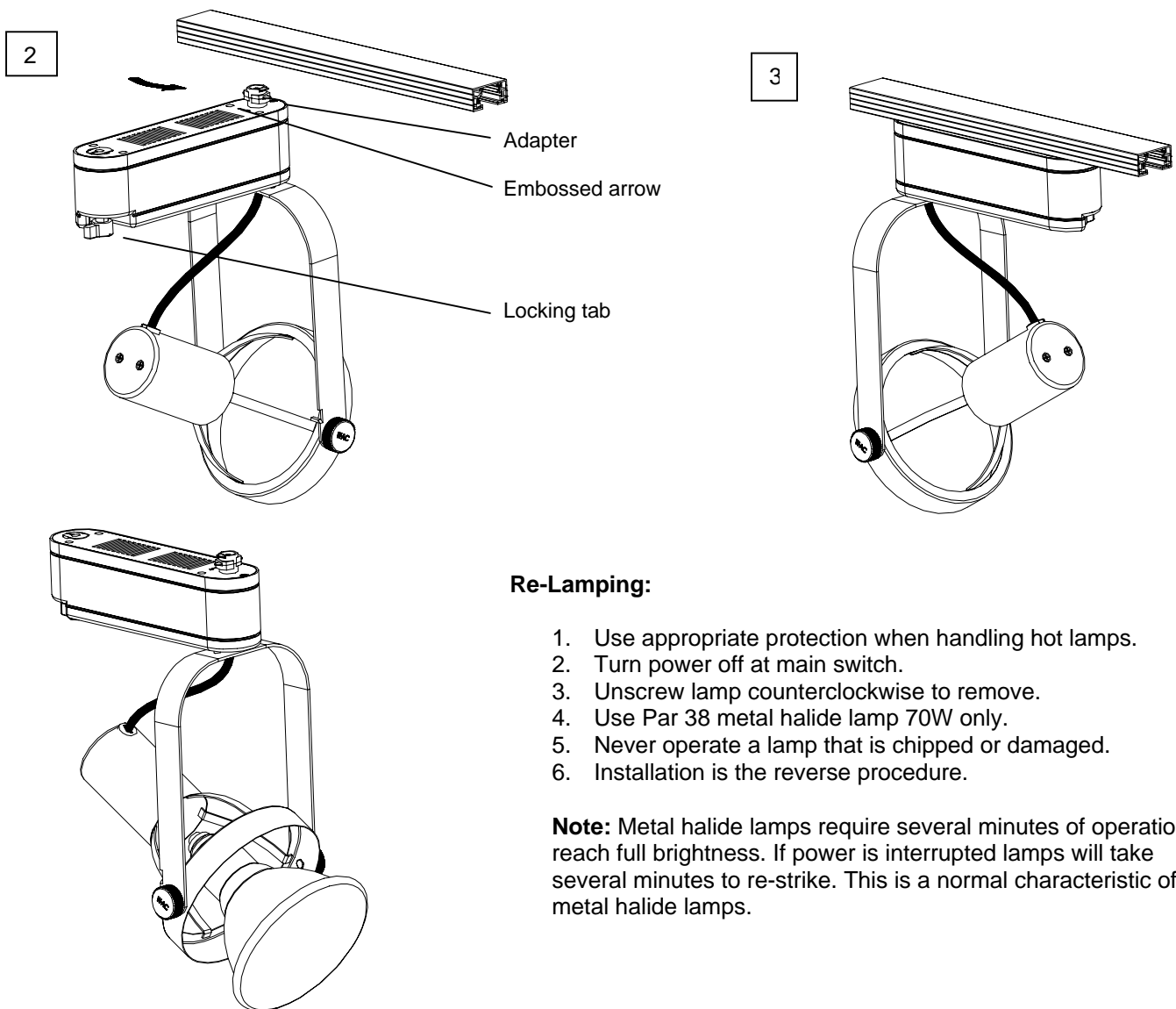

### Re-Lamping:

1. Use appropriate protection when handling hot lamps.
2. Turn power off at main switch.
3. Unscrew lamp counterclockwise to remove.
4. Use Par 38 metal halide lamp 70W only.
5. Never operate a lamp that is chipped or damaged.
6. Installation is the reverse procedure.

**Note:** Metal halide lamps require several minutes of operation to reach full brightness. If power is interrupted lamps will take several minutes to re-strike. This is a normal characteristic of metal halide lamps.



# Installation Instructions: Track Mount- Metal Halide Wall Wash Fixture

## Model: LTK-765-70E

### CAUTION:

For Use with WAC "L" track systems. Fixture may also be used on other manufacturers brand of track (consult factory for compatibility).

CAUTION – To reduce the risk of a burn during relamping, remove from the track before relamping.

Read all instructions before installing.

### Installing Fixtures:

1. Note the track has a ridge running it's length to indicate polarity.
2. The embossed arrow on the adapter should point to the ridged side of the track..
3. Insert adapter into track slot and rotate it 90 °.
4. Push up and turn the locking tab into the lock position.
5. Removal is the reverse procedure. Tracks heads may be positioned anywhere along the track length.

**Note:** "L" series track accepts only W.A.C. track heads.

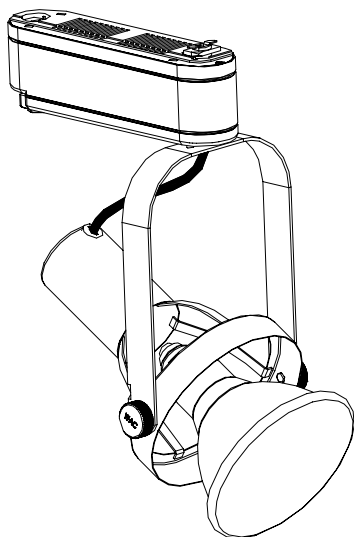
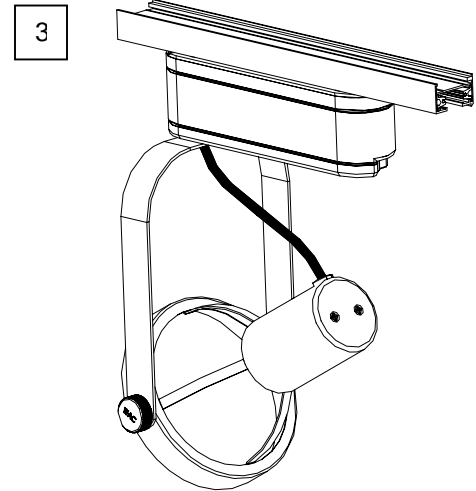
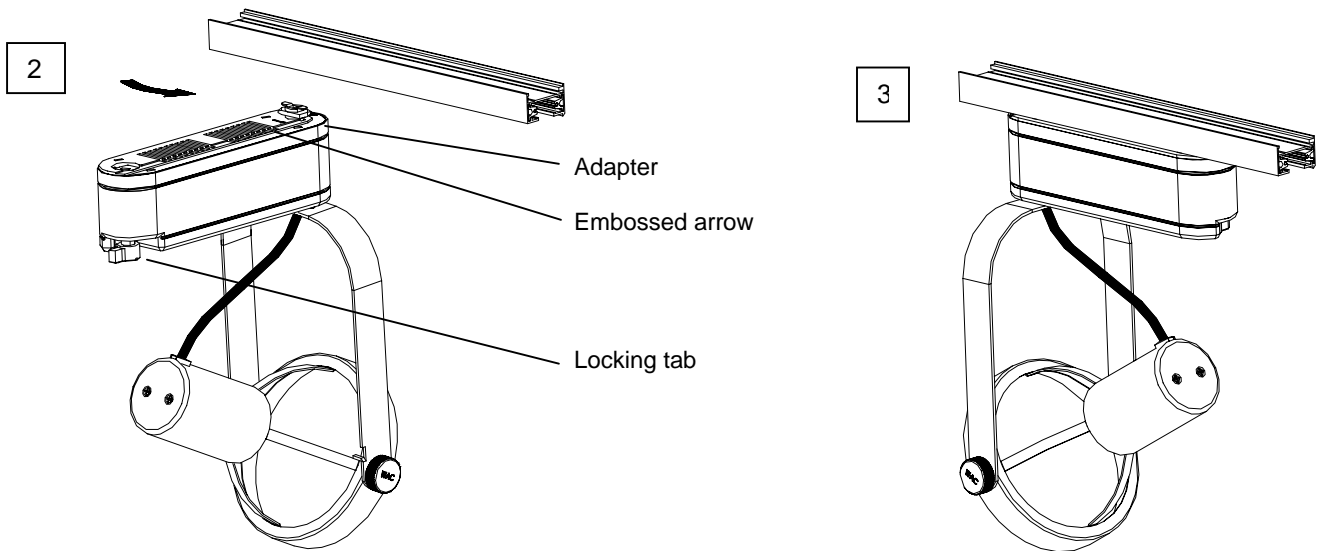

### Re-Lamping:

1. Use appropriate protection when handling hot lamps.
2. Turn power off at main switch.
3. Unscrew lamp counterclockwise to remove.
4. Use Par 38 metal halide lamp 70W only.
5. Never operate a lamp that is chipped or damaged.
6. Installation is the reverse procedure.

**Note:** Metal halide lamps require several minutes of operation to reach full brightness. If power is interrupted lamps will take several minutes to re-strike. This is a normal characteristic of metal halide lamps.



# Installation Instructions: Track Mount- Metal Halide Wall Wash Fixture

## Model: JTK-765-70E

### CAUTION:

For Use with WAC J" & "J2" track systems. Fixture may also be used on other manufacturers brand of track (consult factory for compatibility).

CAUTION – To reduce the risk of a burn during relamping, remove from the track before relamping.

Read all instructions before installing.

### Installing on Track:

1. Note the track has a groove running it's length to indicate polarity.
2. Insert adapter into track slot and rotate it 90° The embossed arrow on the adapter should point to the grooved side of the track.
3. Push up and turn the locking tab into the lock position.
4. Removal is the reverse procedure. Tracks may be positioned anywhere along the track length.

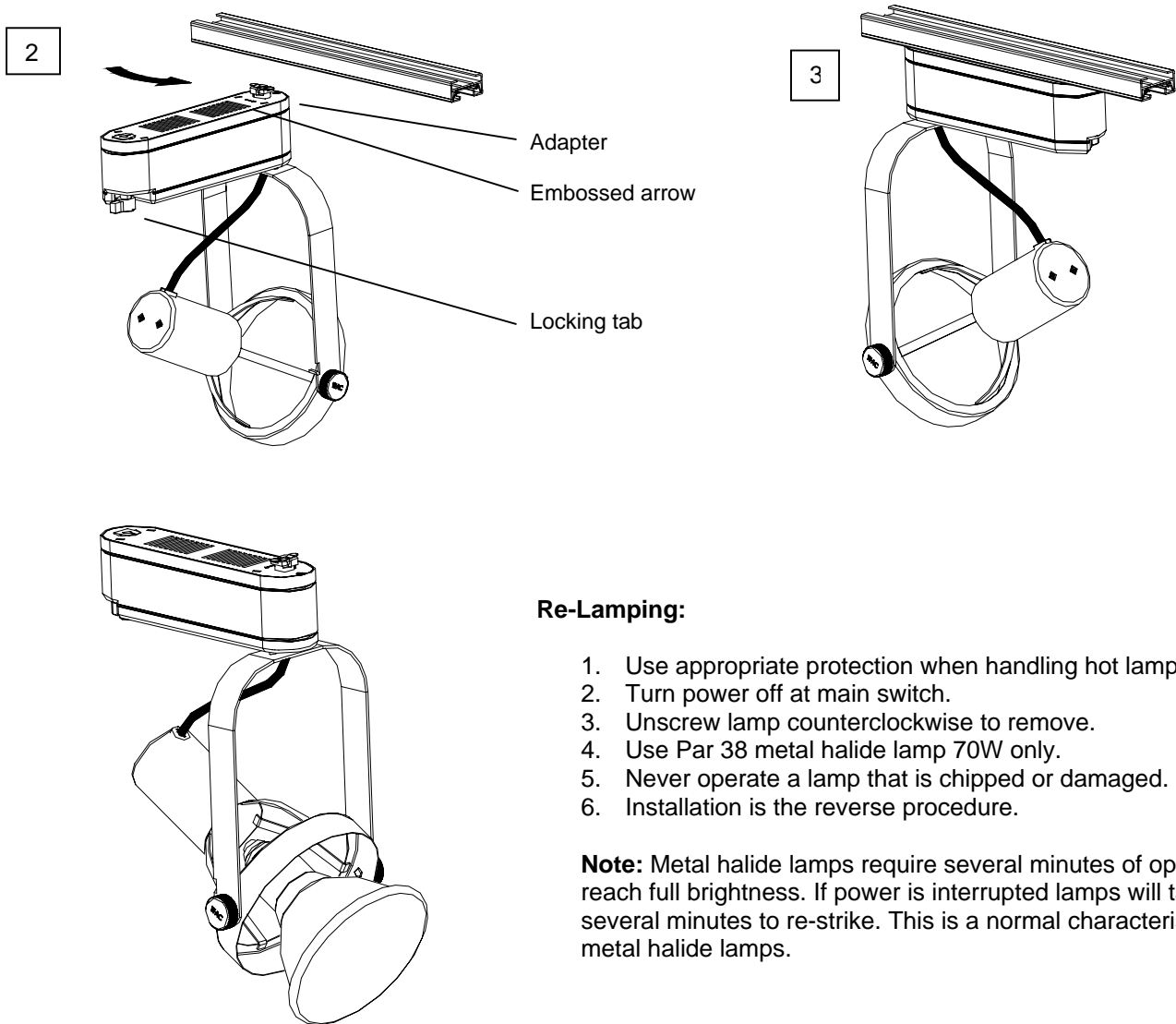

### Re-Lamping:

1. Use appropriate protection when handling hot lamps.
2. Turn power off at main switch.
3. Unscrew lamp counterclockwise to remove.
4. Use Par 38 metal halide lamp 70W only.
5. Never operate a lamp that is chipped or damaged.
6. Installation is the reverse procedure.

**Note:** Metal halide lamps require several minutes of operation to reach full brightness. If power is interrupted lamps will take several minutes to re-strike. This is a normal characteristic of metal halide lamps.

