

# INSTALLATION INSTRUCTION

## Solorail™ System - Low Voltage

LM-T4, LM-T8

WAC LIGHTING  
Responsible Lighting®

### CAUTION:

- Read all instructions.
- Turn off power at main switch before installing or modifying the system.
- Do not conceal or extend exposed conductors through a building wall.
- Do not install any part of this system less than 7 feet ( 2.2m ) above the floor.
- Do not install the system:
  - Within six inches of any curtain or combustible materials
  - In a damp or wet location
- After first 1/2 hour of operation, switch off and check all connections for excessive heat.
- Loose connections must be tightened to prevent overheating which can damage the system and pose a potential fire hazard. Do not over tighten.
- Intended for installation by a qualified electrician.
- Installation should be in accordance with NEC and local codes. Use minimum AWG #10 wire for secondary wiring.

### OVERVIEW:

Flexible low volt Solorail™ is a single circuit rail that can be operated from either 12 or 24-volt power supplies, magnetic or electronic, remote or surface mounted.

Solorail™ fixtures include rail mounted heads, quick connect heads, and quick connect cable hung pendants.

Solorail™ mounts to ceilings by use of metal rod stand offs, or cable and may be used on sloped or suspended ceilings.

### DESIGN CONSIDERATIONS:

Solorail™ is composed of two copper conductors separated by a plastic insulator. It is flexible and bendable. Rail is supplied in 4 or 8 ft lengths and may be field cut. Stand off's are available in 3 to 6 inch lengths, and longer lengths for high ceiling applications. Solorail™ maximum loads are 300 watts at 12 volts and 600 watts at 24 volts. Rail is 25 amp rated. Voltage drop is an important consideration in the initial design. The length of a monorail run depends on the distance from the transformer and the wattage load. Wire gauge size is also a factor in how far a remote transformer may be located from the rail.

Consult the voltage drop guideline chart.

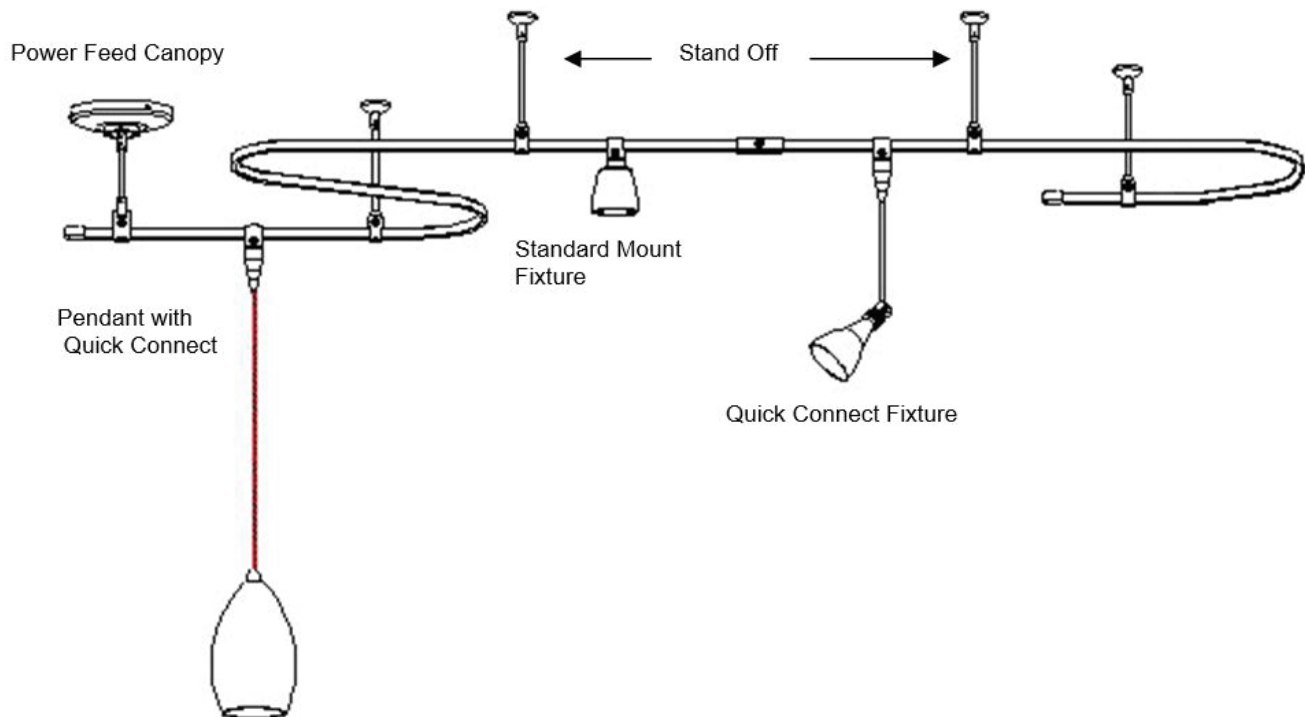

WAC Lighting  
www.waclighting.com  
Phone (800) 526.2588 • Fax (800) 526.2585

Headquarters/Eastern Distribution Center  
44 Harbor Park Drive • Port Washington, NY 11050  
Phone (516) 515.5000 • Fax (516) 515.5050

Western Distribution Center  
1750 Archibald Ave • Ontario, CA 91761  
Phone (800) 526.2588 • Fax (800) 526.2585

# INSTALLATION INSTRUCTION

## Solorail™ System - Low Voltage

LM-T4, LM-T8

WAC LIGHTING  
Responsible Lighting®

### TRANSFORMER SELECTION GUIDE:

Either electronic or magnetic transformers can power monorail. Electronics are smaller than magnetic. The larger magnetic transformers have greater wattage capacities. There is a lesser degree of voltage drop in a magnetic transformer, making them a more practical choice for longer runs (see voltage drop guidelines). Electronic transformers offer quieter operation than magnetics, making them a more practical choice for quiet settings. Magnetic transformers generally contain less components making them among the most reliable power sources.

Either transformer can be used with dimmer switches. An electronic low volt dimmer switch is recommended with any electronic transformer. Electronic transformers are not suitable for multiple switch locations (one switch per transformer). A magnetic transformer requires a low voltage dimmer specifically made for magnetic loads. All dimmers always install on the primary side of the transformer.

Because the Solorail™ system works with 12 or 24 volts we offer transformers for either voltage. The maximum amperage of the rail is 25 amps. You may run 600 watts on a 24 volt system (25 amps) or 300 watts on a 12 volt system (also 25 amps). Our 600 watt transformers are offered in 12 or 24 volts, however the 12 volt version has two outputs with 300 watts available at each.

Transformers are available as surface mounts or remote. Surface mount transformers mount to a junction box, due to their weight it is important that the box be adequately secured to the ceiling structure.

Most of our remote magnetic transformers have a boost tap option, which allows the transformer to be wired for a slightly higher (approximately 10%) voltage output to compensate for voltage drop. To use see instructions furnished with the transformer.

TRANSFORMER SELECTION GUIDELINE				
MODEL	TYPE	INPUT	OUTPUT	MAX WATTS
LM-EN12-75E	Surface Mount LED	120V	12V	75W
LM-EN12-150M	Surface mount magnetic	120V	12V	150W
LM-EN12-300M	Surface mount magnetic	120V	12V	300W
LM-EN12-600M	Surface mount magnetic	120V	12V	600W dual output
LM-EN12-150E	Surface mount electronic	120V	12V	150W
LM-EN12-250E	Surface mount electronic	120V	12V	250W
SRT-300M-12V	Remote magnetic	120V	12V	300W
SRT-300M-24V	Remote magnetic	120V	24V	300W
SRT-600M-12V	Remote magnetic	120V	12V	600W dual output
SRT-600M-24V	Remote magnetic	120V	24V	600W dual output

WAC Lighting  
www.waclighting.com  
Phone (800) 526.2588 • Fax (800) 526.2585

Headquarters/Eastern Distribution Center  
44 Harbor Park Drive • Port Washington, NY 11050  
Phone (516) 515.5000 • Fax (516) 515.5050

Western Distribution Center  
1750 Archibald Ave • Ontario, CA 91761  
Phone (800) 526.2588 • Fax (800) 526.2585

**INSTALLATION INSTRUCTION**  
**Solorail™ System - Low Voltage**

LM-T4, LM-T8

**WAC LIGHTING**  
 Responsible Lighting®

<b>VOLTAGE DROP GUIDELINE</b>										
<b>SURFACE MOUNT TRANSFORMERS</b>										
CAT. NO.	VOLTS	WATTS	TYPE	RAIL RUN LENGTH						
LM-EN12-75E	12V	75W	ELECTRONIC	(9) 9W LED fixtures						
LM-EN12-150M	12V	150W	MAGNETIC	40'						
LM-EN12-150E	12V	150W	ELECTRONIC	20'						
LM-EN12-250E	12V	250W	ELECTRONIC	16'						
LM-EN12-300M	12V	300W	MAGNETIC	40'						
LM-EN12-600M	12V	(2) 300W	MAGNETIC	(2) 40'						
<b>REMOTE TRANSFORMERS- to power feed point</b>										
CAT.NO.	VOLTS	WATTS	TYPE	WIRE GAUGES/ MAX DISTANCE- FEET						RAIL RUN LENGTH/FT
				10	8	6	4	2	1	
SRT-300M-12V*	12V	300W	MAGNETIC	9'	10'	25'	40'	60'	100'	40'
SRT-300M-24V*	24V	300W	MAGNETIC	15'	20'	40'	60'	100'	150'	80'
SRT-600M-12/24V*	12/V	(2) 300W	MAGNETIC	9'	10'	25'	40'	60'	100'	(2) 40'
SRT-600M-12/24V*	24V	(1) 600W	MAGNETIC	9'	10'	25'	40'	60'	100'	40'

\* Transformers with booth tap option increases voltage approximately 10%.  
 Remote transformer data based on a full load with 5% max voltage drop.  
 Surface mount data based on full load to end of rail.

**DEBUZZING COIL:**

Inherent with all magnetic transformers is an audible buzz, mostly when dimmed. To lessen the noise, our surface mount transformers are supplied with a factory installed debuzzing coil (or choke). The debuzzing coil is an option on remote magnetic transformers. Debuzzing coils are installed between the switch and transformer on the black (hot) primary wire.

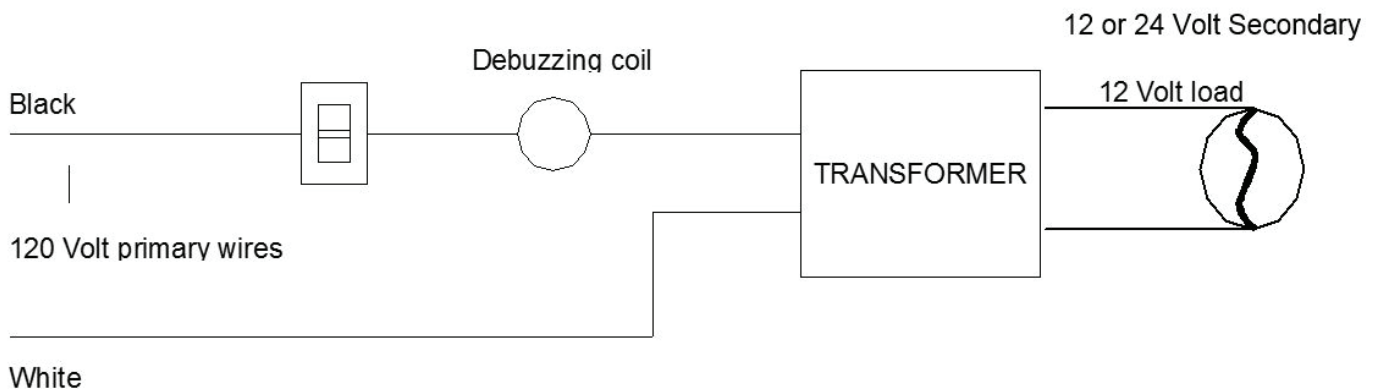

WAC Lighting  
 www.waclighting.com  
 Phone (800) 526.2588 • Fax (800) 526.2585

Headquarters/Eastern Distribution Center  
 44 Harbor Park Drive • Port Washington, NY 11050  
 Phone (516) 515.5000 • Fax (516) 515.5050

Western Distribution Center  
 1750 Archibald Ave • Ontario, CA 91761  
 Phone (800) 526.2588 • Fax (800) 526.2585

# INSTALLATION INSTRUCTION

## Solorail™ System - Low Voltage

LM-T4, LM-T8

# WAC LIGHTING

Responsible Lighting®

### TRANSFORMER INSTALLATION:

Determine if a remote or surface mount transformer will be used, proceed as indicated below.

### INSTALLING A REMOTE TRANSFORMER:

1. Locate the transformer as close as possible to the power feed point to minimize voltage drop.
2. Connect line voltage wires to their respective transformer input wires, ( white to white & black to black).
3. Make ground wire connection. Note: Some remote transformers have integral enclosures with a green wire, if not, an enclosure is required. Establish a ground connection to the enclosure.
4. To wire secondary wires, first determine the appropriate THHN wire gauge size for the distance between the transformer and the junction box. See voltage drop chart . Run secondary wires from transformer to power in walls and ceilings should be enclosed type ie: BX, Romex, MC.
5. Select a knock out hole in the power feed canopy back plate.
6. Support the power feed canopy, and route wires from the canopy through the the knock out hole into the junction box.
7. Attach canopy wires to the transformer wires with wire nuts (supplied). Tuck wires back into the junction box.
8. Secure the base plate to the junction box, through the slotted holes.
9. Loosen the the three screws on the canopy. Raise the power feed canopy to the base plate and partially tighten screws so that they support the weight of the canopy.
10. Rotate the canopy so the power feed adapter aligns with the rail, then fully tighten screws.
11. For locations where no junction box is present secure the back plate to the surface, and make wire connections in the canopy.
12. **NOTE:** Low voltage systems require firm connections at all points, to avoid abnormal heat conditions. A loose connection can lead to system damage and potential fire hazzard. Correct by tightening, but do not over tighten. The recheck the hot spot to make certain it's corrected.

120V input wires

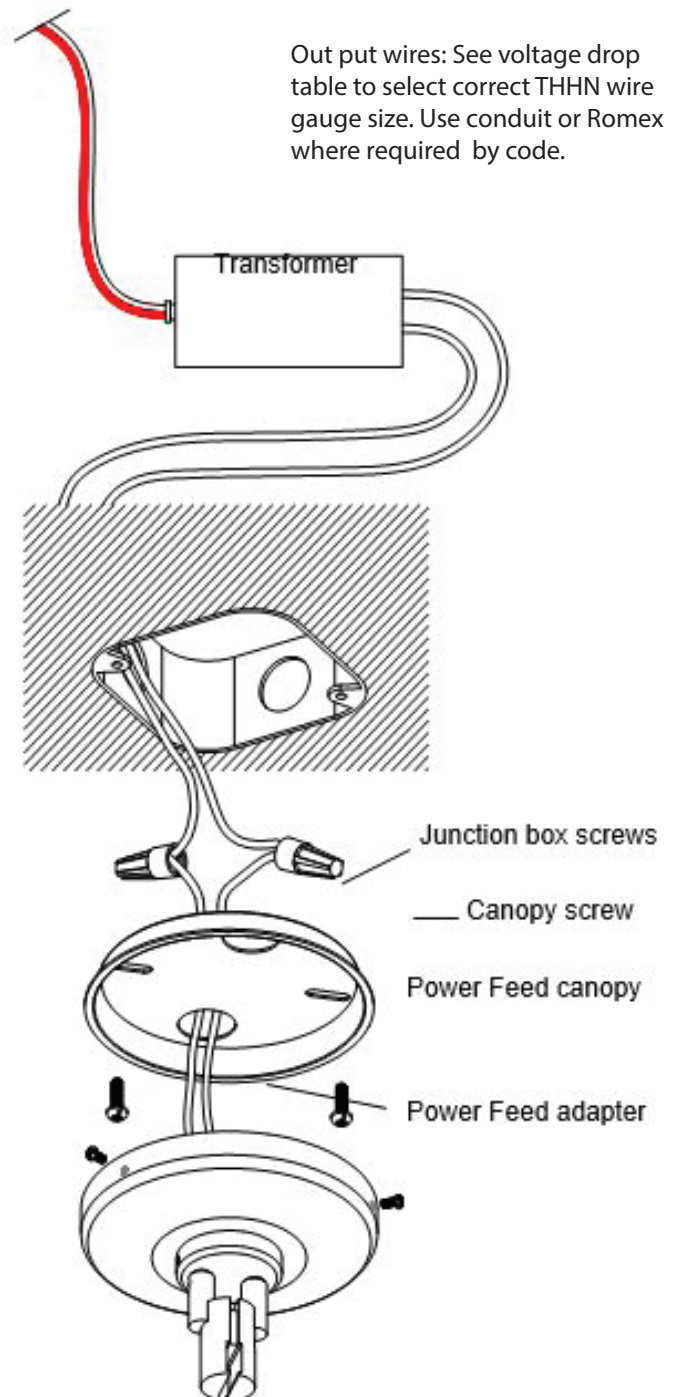

WAC Lighting  
www.waclighting.com  
Phone (800) 526.2588 • Fax (800) 526.2585

Headquarters/Eastern Distribution Center  
44 Harbor Park Drive • Port Washington, NY 11050  
Phone (516) 515.5000 • Fax (516) 515.5050

Western Distribution Center  
1750 Archibald Ave • Ontario, CA 91761  
Phone (800) 526.2588 • Fax (800) 526.2585

# INSTALLATION INSTRUCTION

## Solorail™ System - Low Voltage

LM-T4, LM-T8

# WAC LIGHTING

Responsible Lighting®

### INSTALLING A SURFACE MOUNTED TRANSFORMER:

1. The junction box will support the entire weight of the transformer, which may weigh up to 18 lbs.; make sure it is adequately braced and supported. It is recommended that two people install the transformer.
2. Extension wires are supplied to connect junction box wires to the transformer input wires. Connect white neutral wire to white wire, and black hot wire to black wire with wire nuts. The ground wire may be green or bare copper, connect it to the green extension wire.
3. Pass the open ends of the wires through the center hole of the cross bar/ threaded tube assembly, and mount to cross bar junction box as shown.
4. Open the transformer case by removing the four screws on the perimeter. The cover halves will separate but not detach, allow the lower half to hang temporarily.
5. Raise the transformer assembly on to the threaded tube and pass the ends of the wires through. Attach the heavy nut to the bottom of the tube and tighten so the transformer assembly is close to the ceiling.
6. Insert pin through hole on bottom of treaded tube to secure heavy nut to tube.
7. Connect the extension wires to the transformer input wires, with wire nuts. Follow the previous color code.
8. Position the bottom cover so the power feed adapter is aligned to receive Solorail™. Close the bottom cover and secure with the four screws removed earlier.

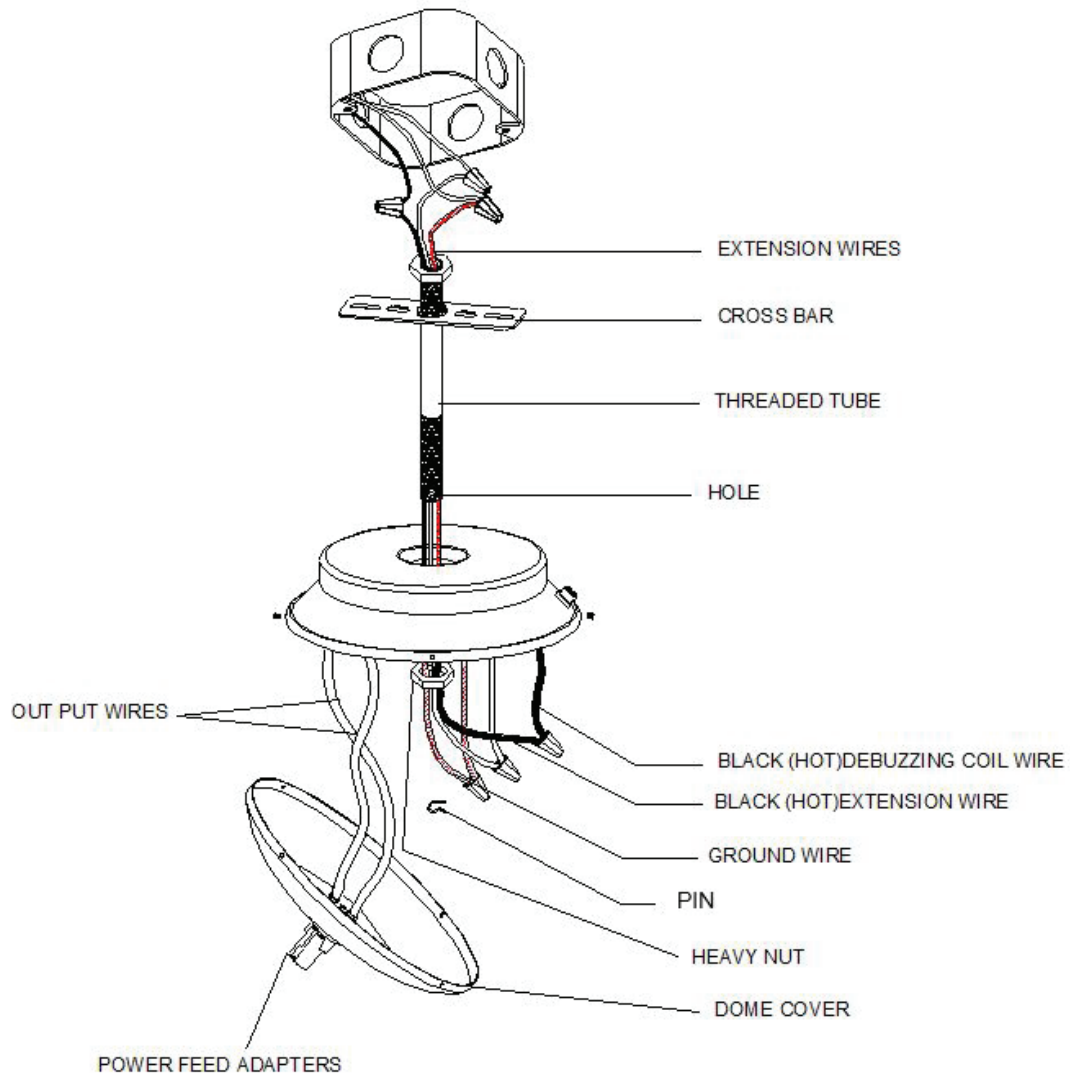

WAC Lighting  
www.waclighting.com  
Phone (800) 526.2588 • Fax (800) 526.2585

Headquarters/Eastern Distribution Center  
44 Harbor Park Drive • Port Washington, NY 11050  
Phone (516) 515.5000 • Fax (516) 515.5050

Western Distribution Center  
1750 Archibald Ave • Ontario, CA 91761  
Phone (800) 526.2588 • Fax (800) 526.2585

# INSTALLATION INSTRUCTION

## Solorail™ System - Low Voltage

LM-T4, LM-T8

WAC LIGHTING  
Responsible Lighting®

### CEILING POWER FEED CONNECTION: "LM-CPC"

1. Position the transformer or power feed canopy, so the power feed adapters align with the rail.
2. Loosen the set screw in the adapter, so that there is sufficient clearance to slip the monorail between the two halves.
3. Gently seat the rail in position and tighten the adapter screw, making sure the rubber separator stays in position.
4. Check the fit of the rail, to make sure it fits flat against the adapter channel. Complete contact is necessary for proper performance.
5. After the first ½ hour of operation, switch off and check connections for excessive heat or color distortion. Low voltage systems operate at higher amperage, which requires secure connections. A loose connection can lead to system damage and potential fire hazard. Correct by tightening, but do not over tighten. The recheck the hot spot to make certain it's corrected.

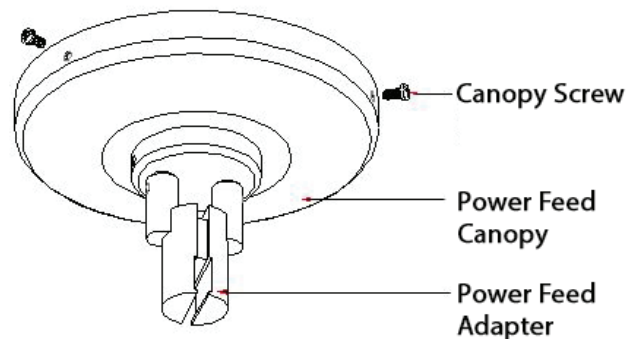

### INSTALLING A REMOTE TRANSFORMER:

The wall mount power feed installation is the same as ceiling mount. It differs from the ceiling mount in that the power feed adapter is shaped to accept rail from it's end.

### MONORAIL MOUNTING:

Rail can be installed on a flat surface, a sloped ceiling, or a suspended ceiling.

1. Use a standoff for every 42" of rail. Use additional standoffs to support tightly curved sections .
2. If bending rail, do this at floor level, then raise to ceiling and mark the location of standoff supports.
3. If rail cannot be raised, use a plumb line to mark location of stand offs on the ceiling.
4. For drywall, drill holes and insert ceiling anchors (supplied) through standoff bases and then to ceiling (shown). Tighten until snug.

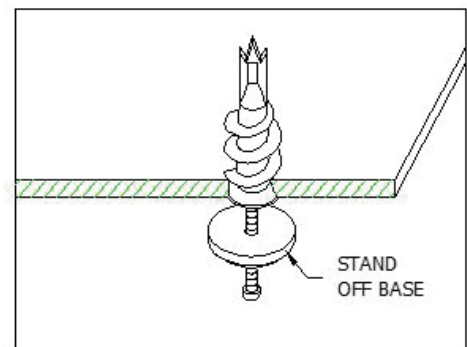
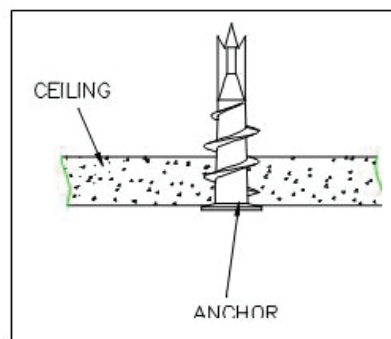
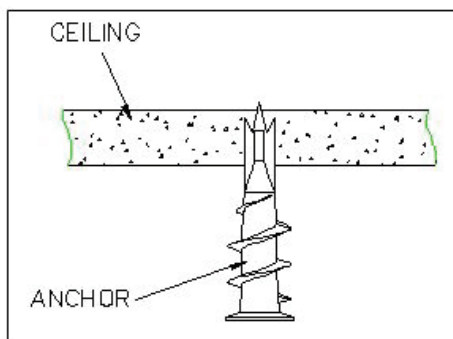
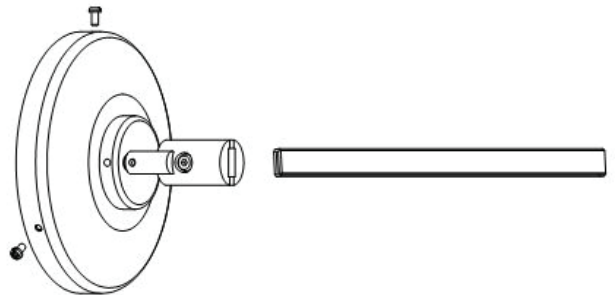

WAC Lighting  
www.waclighting.com  
Phone (800) 526.2588 • Fax (800) 526.2585

Headquarters/Eastern Distribution Center  
44 Harbor Park Drive • Port Washington, NY 11050  
Phone (516) 515.5000 • Fax (516) 515.5050

Western Distribution Center  
1750 Archibald Ave • Ontario, CA 91761  
Phone (800) 526.2588 • Fax (800) 526.2585

# INSTALLATION INSTRUCTION

## Solorail™ System - Low Voltage

LM-T4, LM-T8

WAC LIGHTING  
Responsible Lighting®

- For wood surfaces insert wood screws through standoff bases and fully tighten.
- Install standoff posts with rail adapters. Twist clock wise to tighten.
- To obtain proper alignment with Solorail™ loosen the set screw near the top of the standoff, (using a 1/16" allen wrench) adjust then re-tighten.
- Loosen the set screw in the rail adapter, so that there is sufficient clearance to slip the rail between the two halves.
- Raise the rail to ceiling level and support it.
- Starting from the center of rail, slip track between the two halves of the rail adapter. Tighten the adapter screw (clockwise) until the rail adapter seats firmly against both sides of the rail.
- Repeat procedure for remaining standoffs

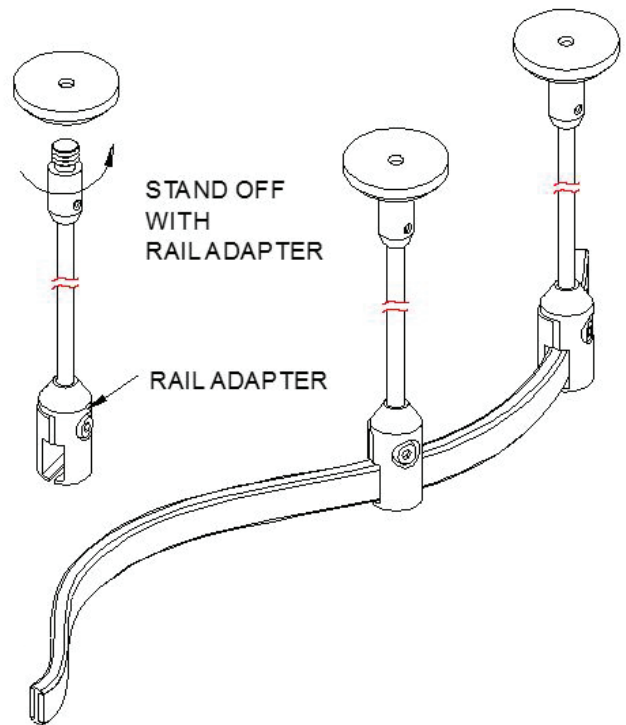

### FIELD CUTTING A STANDOFF:

- Remove the small setscrew located on the upper fitting and pull the rod free (use a 1/16" allen wrench).
- Use a tube cutter for the cleanest cut. If using a hacksaw be sure to brush away any metal filings.
- Cut to size and refit.
- The procedure for standoffs on the power feed canopy is the same

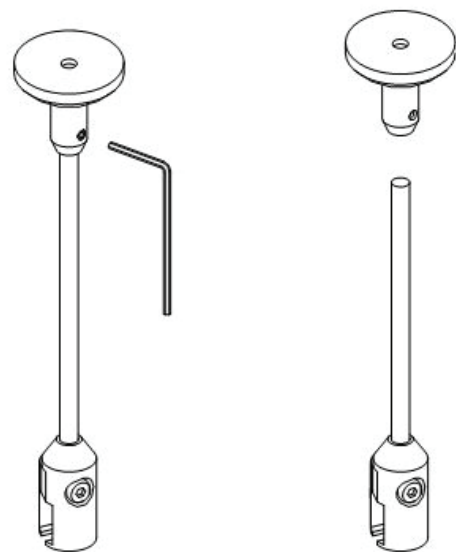

WAC Lighting  
www.waclighting.com  
Phone (800) 526.2588 • Fax (800) 526.2585

Headquarters/Eastern Distribution Center  
44 Harbor Park Drive • Port Washington, NY 11050  
Phone (516) 515.5000 • Fax (516) 515.5050

Western Distribution Center  
1750 Archibald Ave • Ontario, CA 91761  
Phone (800) 526.2588 • Fax (800) 526.2585

# INSTALLATION INSTRUCTION

## Solorail™ System - Component

LM-T4, LM-T8

WAC LIGHTING  
Responsible Lighting®

### **"I"CONNECTOR** - LM-I

Connects two sections of rail and allows current flow between the two.

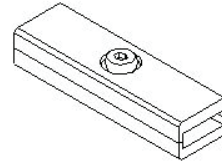

### **"I"DEAD END CONNECTOR** - LM-IDEC

Connects two pieces of rail, but is non-conductive and does not allow current to pass to the other section.

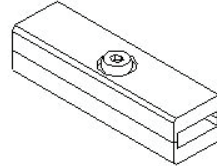

### **"L"CONNECTOR** - LM-L

Used to join two rail sections at a 90° angle.

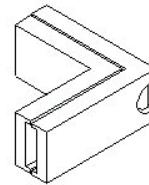

### **"T"CONNECTOR** - LM-T

Joins three rails in a "T" configuration.

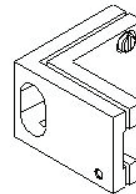

### **"X"DEAD END CONNECTOR** - LM-XDEC

Connects four sections of rail, but is non-conductive and does not allow current to pass to the other sections.

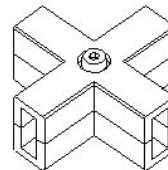

### **CEILING TO WALL "L"CONNECTOR** - LM-CW

Joins rail sections on a vertical plane to allow a transition from a wall to ceiling

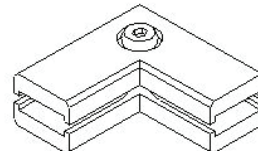

### **JUMPER SET** - LM-JS

Connects two monorail sections with a flexible wire allowing variable angles. Length is 8.5".



WAC Lighting  
www.waclighting.com  
Phone (800) 526.2588 • Fax (800) 526.2585

Headquarters/Eastern Distribution Center  
44 Harbor Park Drive • Port Washington, NY 11050  
Phone (516) 515.5000 • Fax (516) 515.5050

Western Distribution Center  
1750 Archibald Ave • Ontario, CA 91761  
Phone (800) 526.2588 • Fax (800) 526.2585



# INSTALLATION INSTRUCTION

## Solorail™ System - Component

LM-T4, LM-T8

WAC LIGHTING  
Responsible Lighting®

### T-BAR CEILINGS

**NOTE:** Rail stand offs are required to be mounted to structural members. Do not mount only to acoustical panels.

1. Follow steps 1 through 3 for rail mounting above.
2. Place T-bar clip standoff against the ceiling T-bar, and turn clockwise to engage.
3. Proceed from step 5 above.

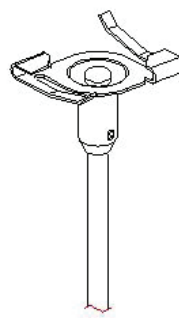

T BAR

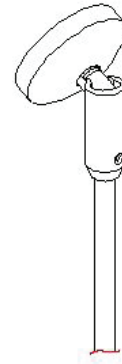

SLOPED CEILING

### BENDING SOLORAIL™

1. Rail is best formed, by bending over a round object.
2. Start with a broader radius and form over progressively smaller diameters.
3. We recommend a minimum radius of 12".
4. Broad curves can be accomplished by gradual hand bending.
5. Once formed, the ends of the rail will be unequal. If connecting with another connector, snip the rail end to make even, other wise just apply an end cap.
6. Pre-stress track to shape while at floor level. Do not stress between ceiling standoffs to form shapes.

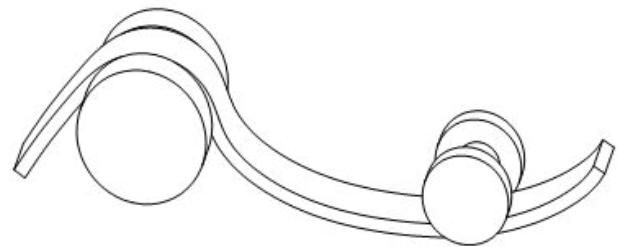

### FIELD CUTTING RAIL

1. Rail may cut to length in field.
2. Use fine-toothed hacksaw or heavy-duty bolt cutter.
3. Thoroughly clear away all cutting debris.
4. Inspect end to insure the insulator has not been damaged and there are no sharp edges.
5. Re-install track end cap.

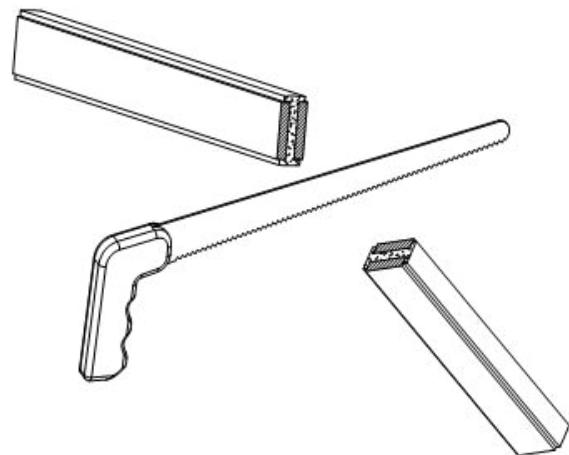

WAC Lighting  
www.waclighting.com  
Phone (800) 526.2588 • Fax (800) 526.2585

Headquarters/Eastern Distribution Center  
44 Harbor Park Drive • Port Washington, NY 11050  
Phone (516) 515.5000 • Fax (516) 515.5050

Western Distribution Center  
1750 Archibald Ave • Ontario, CA 91761  
Phone (800) 526.2588 • Fax (800) 526.2585

INSTALLATION INSTRUCTION  
**Solorail™ System - Component**  
LM-T4, LM-T8

WAC LIGHTING  
Responsible Lighting®

**INSTALLING FIXTURES:**

**NOTE:** Fixtures attach to the rail with a two-piece adapter. It is important that the setscrews of the adapter all face the same way. This reduces the possibility of an electrical short.

1. Loosen the adapter screw enough to allow adapter halves to slip over Solorail™.
2. Seat the adapter notches to the rail and tighten the screw.
3. Inspect the rail to see that the adapters are firm against it.
4. If the adapter is the quick connect type, thread the quick connect adapter by screwing clockwise until snug.

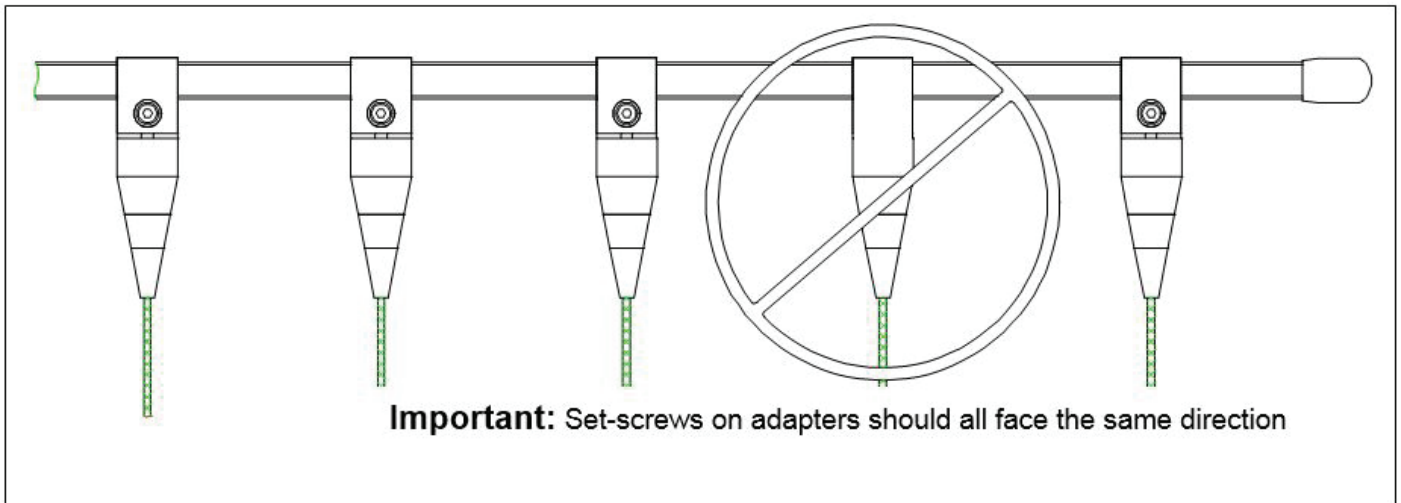
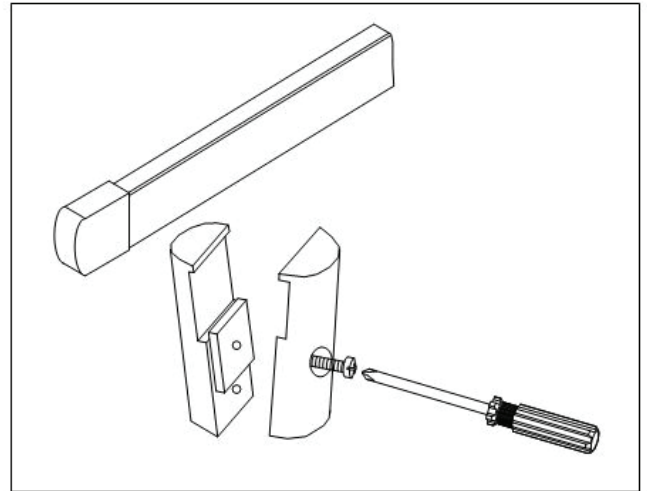

**IMPORTANT:** Observe polarity, install rail adapters with screws facing the same side of the rail.

WAC Lighting  
www.waclighting.com  
Phone (800) 526.2588 • Fax (800) 526.2585

Headquarters/Eastern Distribution Center  
44 Harbor Park Drive • Port Washington, NY 11050  
Phone (516) 515.5000 • Fax (516) 515.5050

Western Distribution Center  
1750 Archibald Ave • Ontario, CA 91761  
Phone (800) 526.2588 • Fax (800) 526.2585