

INSTALLATION INSTRUCTION

PATH LIGHT

6011 / 6021 / 6031

WAC LIGHTING

Responsible Lighting®

SAFETY INSTRUCTION

IMPORTANT: NEVER attempt any work without shutting off the electricity.

- Read all instructions before installing.
- System is intended for installation by a qualified electrician in accordance with the National Electrical Code and local regulations.
- Place the wall switch in the "OFF" position.
- Go to the main fuse box, or circuit breaker. Unscrew the fuse(s) or switch "OFF" the circuit breaker switch(es) that control the power to the space that you are working on.

CAUTION:

All parts must be used as indicated in these instructions. Do not substitute any parts, leave parts out, or use any parts that are worn out or broken. Failure to follow this instruction could invalidate the ETL/cETL listing of this fixture.

AVERTISSEMENT

IMPORTANT : COUPEZ L'ÉLECTRICITÉ AVANT TOUTE MANIPULATION.

- Lisez toutes les instructions avant d'installer.
- Système est destiné à être installé par un électricien qualifié en conformité avec le code national de l'électricité et les règlements locaux.
- Placez l'interrupteur mural en position d'arrêt (« OFF »).
- Accédez au panneau central de disjoncteurs ou de fusibles de votre demeure et placez l'interrupteur principal en position d'arrêt (« OFF »).

MISE EN GARDE

Toutes les pièces doivent être utilisées tel qu'il est indiqué dans ces instructions. Ne remplacez pas les pièces, n'en laissez pas de côté et ne les utilisez pas si elles sont usées ou brisées. Le non-respect de ces instructions peut annuler l'homologation ETL/cETL du luminaire.

THIS INSTRUCTIONS APPLY TO THE MODELS BELOW:

**Note: Transformer is required to power the fixture. (sold separately)*

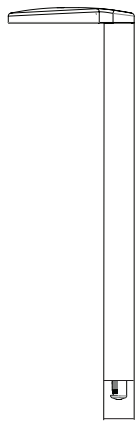

6011



6021

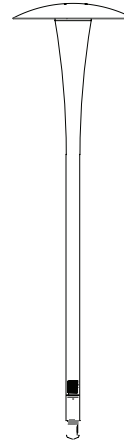

6031

Mounting Accessories (included in box)



Mounting Stake
Qty: 1pc



Outdoor Rated Wire Nut
Qty: 2pcs

waclighting.com
Phone (800) 526.2588
Fax (800) 526.2585

Headquarters/Eastern Distribution Center
44 Harbor Park Drive
Port Washington, NY 11050

Central Distribution Center
1600 Distribution Ct
Lithia Springs, GA 30122

Western Distribution Center
1750 Archibald Avenue
Ontario, CA 91760

INSTALLATION INSTRUCTION

PATH LIGHT

6011 / 6021 / 6031

WAC LIGHTING

Responsible Lighting®

INSTALLATION

STEP 1:

1. Make sure your main power is off.
2. At the point of installation, mount the stake by placing a piece of wood on the stake and hammering the wood. Hammer till the bottom of the ring is flush with the ground.
3. In the case of hard soil, dig a hole and place the stake in so that the bottom of the ring is flush with the ground. Fill the rest of the hole with the removed soil and pack it tight to secure the stake.
4. Screw the fixture onto the stake provided, leading the wire from the fixture through the wire slot in the stake.

STEP 2:

5. Cut the power supply wire from the transformer at the location of the fixture.
6. Separate the power supply wire into two individual wires by lightly pulling on each side so that a couple inches is separated.
7. Strip off ½ inch of the insulating material from each wire and connect one to each of the wires from the fixture using the outdoor rated direct burial wire nuts provided.

STEP 3:

8. Screw the fixture onto the stake provided, leading the wire from the fixture through the wire slot in the stake.
9. If desired, bury your wire by digging a small trench. Close the trench by applying an inward force to both sides of the trench.
10. Repeat steps for other fixtures in the same electrical circuit.
11. Turn the main power supply back on and make sure the fixtures light up.

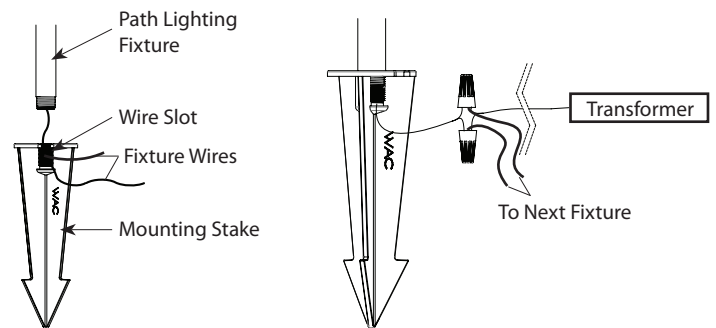
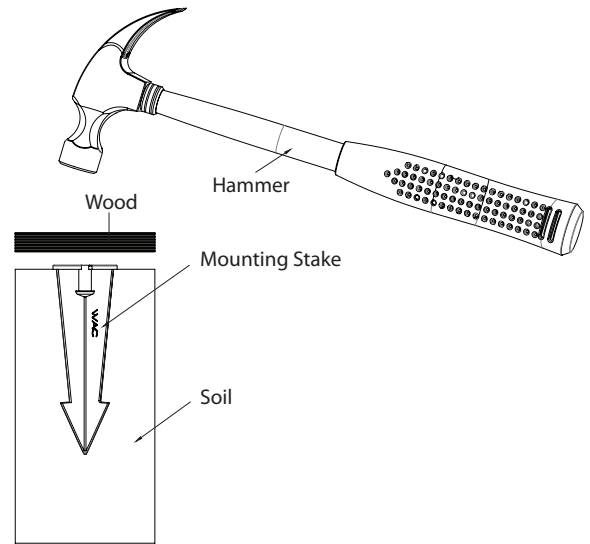

Note: To install multiple fixtures, also connect the power supply wire of each additional fixture to the connection described in 7 of the previous fixture.

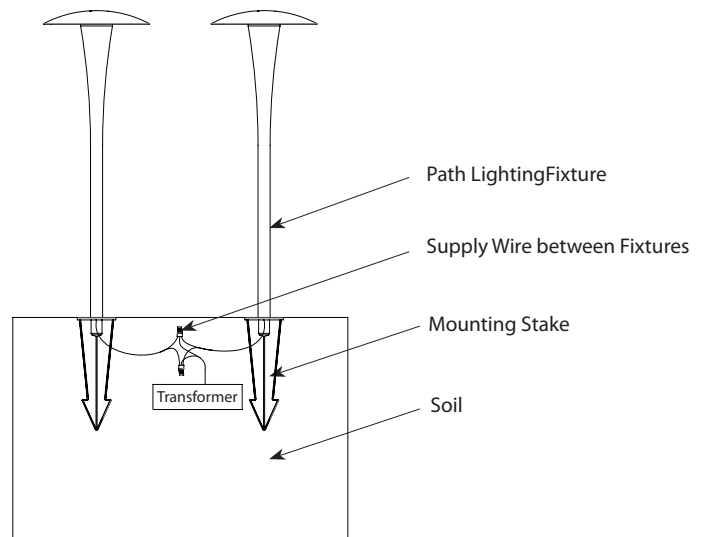

waclighting.com
Phone (800) 526.2588
Fax (800) 526.2585

Headquarters/Eastern Distribution Center
44 Harbor Park Drive
Port Washington, NY 11050

Central Distribution Center
1600 Distribution Ct
Lithia Springs, GA 30122

Western Distribution Center
1750 Archibald Avenue
Ontario, CA 91760

INSTALLATION INSTRUCTION

PATH LIGHT

6011 / 6021 / 6031

WAC LIGHTING
Responsible Lighting®

INSTALLING THE SURFACE MOUNT ACCESSORY

Softscape Installation:

1. Attach the three removable spikes to the surface mount accessory by screwing them in.
2. Using a piece of wood to buffer the impact, hammer the assembled mount into the soil till the bottom of the surface mount accessory is flush with the ground.
3. Lead your wire through the wire slot and screw in your fixture.
4. Connect fixture wires to power supply wires as normal using the outdoor rated direct burial wire nuts provided.

Hardscape Installation:

1. Mount the accessory to the surface using No. 10 Philips head screws that are at least half an inch long.
2. If mounting on concrete or something similar, first use plastic anchors sized for No. 10 screws.
3. Create a route underneath the accessory for your wire to travel through.
4. Lead your wire through the created route and screw your fixture onto the surface mount accessory.

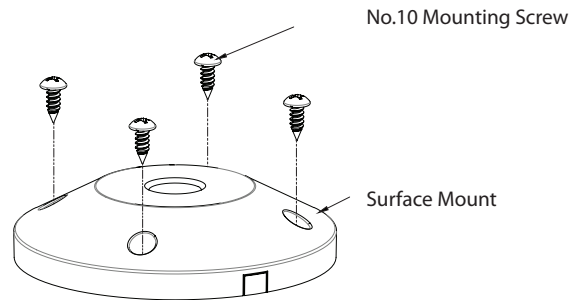
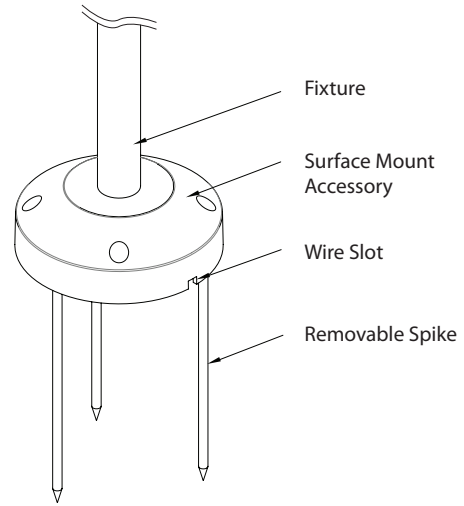

waclighting.com
Phone (800) 526.2588
Fax (800) 526.2585

Headquarters/Eastern Distribution Center
44 Harbor Park Drive
Port Washington, NY 11050

Central Distribution Center
1600 Distribution Ct
Lithia Springs, GA 30122

Western Distribution Center
1750 Archibald Avenue
Ontario, CA 91760