

HMI VOLCANO UL (1-4-2801-0222)

Installation and operating instructions



Table of Contents

1.	Important information for installers and final users.....	1
2.	Manufacturer information	1
3.	The purpose of the HMI VOLCANO UL (1-4-2801-0222).....	1
4.	Terminals of the HMI VOLCANO UL	1
5.	Installation and wiring.....	1
5.1.	Connection of HMI VOLCANO UL controller to the Volcano VR Mini EC, VR1 EC, VR2 EC, VR3 EC	2
5.2.	Connection of HMI VOLCANO UL controller to the Volcano VR-D Mini EC and VR-D EC air destratifier.....	2
5.3.	Controller Flush mounting	3
5.4.	Other Installation facts and recommendations.....	3
6.	Operations on the HMI VOLCANO UL Controller	3
6.1.	Front panel.....	3
6.2.	Display	4
6.3.	SWITCHING the controller on and off	4
6.4.	Main SETTINGS	4
6.5.	Time schedule settings	5
6.5.1.	Time/day setting.....	5
6.5.2.	Schedule setting	5
7.	Programming mode.....	5
7.1.	Advanced settings, section A	5
7.2.	Advanced Settings, section B.....	5
8.	Technical Specification	6

1. IMPORTANT INFORMATION FOR INSTALLERS AND FINAL USERS

This controller should be:

- Installed only by qualified personnel in accordance with local and national regulations.
- Mounted properly as described in the manual, so the casing or enclosure is only accessible to the end user and protection against electric shock is assured.
- Proper installation is intended to care of the Class II requirements (reinforced insulation) to prevent electric shock hazard.

2. MANUFACTURER INFORMATION

This product is manufactured by **VTS AMERICA Inc**
 3535 Gravel Springs Rd. Extension, Suite 201
 GA 30519 Buford,

Phone: 001 470-809-6811,
 Fax: 001 470-809-6815,
 E-mail address: america@vtsgroup.com

3. THE PURPOSE OF THE HMI VOLCANO UL (1-4-2801-0222)

HMI VOLCANO UL unit is an electronic controller dedicated for range of VOLCANO unit heaters and air destratifiers. The controller manages the unit's performance by means of fan revolutions and air heating capacity regulation, also supported by the time schedule.

The HMI VOLCANO UL is equipped with Modbus RTU port supporting two-ways communication with BMS systems. This controller is dedicated for the following range of VOLCANO Air Heaters manufactured by VTS:

HMI VOLCANO UL
(1-4-2801-0222)



VR Mini EC



VR 1 EC, VR 2 EC, VR 3 EC



VR-D MINI EC



VR-D EC



CAUTION. This HMI VOLCANO UL should not be used as a controller for any other products than above listed.

4. TERMINALS OF THE HMI VOLCANO UL

This HMI VOLCANO UL controller has a range of terminals available on the back panel of it.

Function of each terminal is listed below:

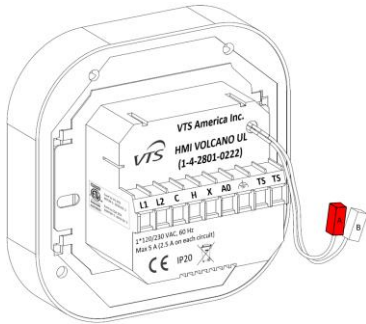

- L1 – Power supply phase
- L2 – Power supply phase
- C – Not connected (N/C)
- H – Heat - Digital relay output
- X – Not connected (N/C)
- A0 – 0-10 Volts analog output for fan speed regulation
- ⏏ – Reference ground for 0-10 V communication
- TS (left) – Optional air temperature sensor
- TS (Right) – Optional air temperature sensor
- A, B – RS-485 ModBUS RTU - BMS communication port

5. INSTALLATION AND WIRING

Caution. Before attempting to any installation works, ensure that VOLCANO unit (being a power supply source for this controller) is mechanically disconnected from electric power supply.

Apply one of the following connection methods, depending on the or VOLCANO unit you have

- The VR Mini EC, VR1 EC, VR2 EC and VR3 EC units are equipped with hydronic heater.
- The VR-D EC and VR-D Mini EC are Air Destratifiers only – with no heating coil at all.

5.1. CONNECTION OF HMI VOLCANO UL CONTROLLER TO THE VOLCANO VR MINI EC, VR1 EC, VR2 EC, VR3 EC

Connect the HMI VOLCANO UL to the VR Mini EC, VR1 EC, VR2 EC or VR3 EC, according to diagram shown on Figure 1.

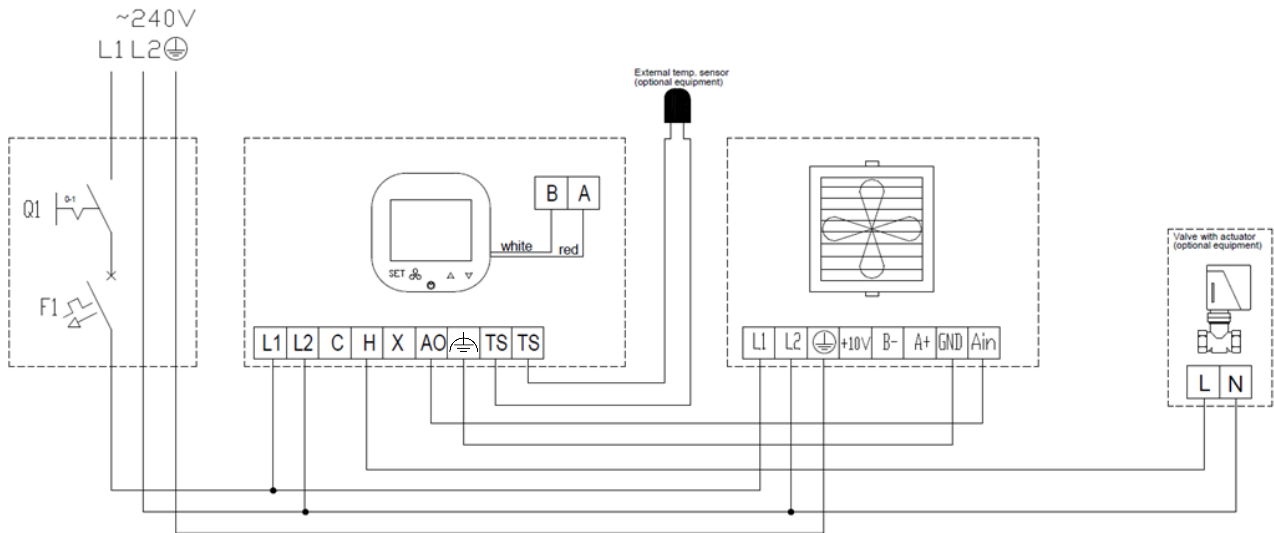

Figure 1 - VR MINI, VR1, VR2, VR3 connections

Tip: for VOLCANO VR Mini EC, VR1 EC, VR2 EC and VR3 EC (unit heaters with water heating coil), an auxiliary external temperature sensor can be applied (out of VTS delivery) and connected to ports TS / TS of the controller. The supported temperature sensor type is **NTC 10kΩ**.

Tip: A two-way valve for water heater flow opening and closing can be connected to the H port of the controller and the L2.

5.2. CONNECTION OF HMI VOLCANO UL CONTROLLER TO THE VOLCANO VR-D MINI EC AND VR-D EC AIR DESTRATIFIER.

Connect the HMI VOLCANO UL to the VR-D Mini and VR-D air destratifiers, according to diagram shown on Figure 2.

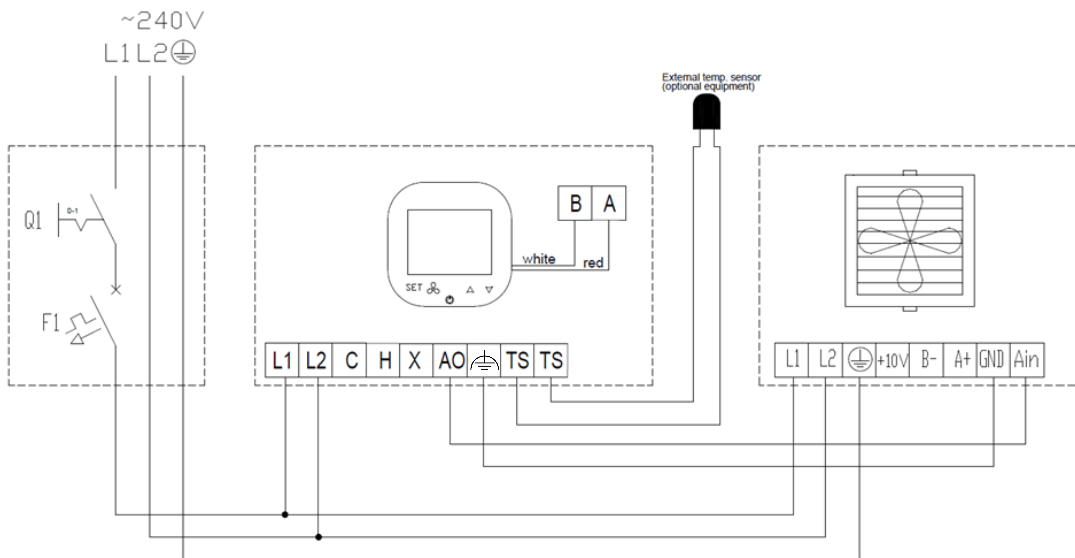
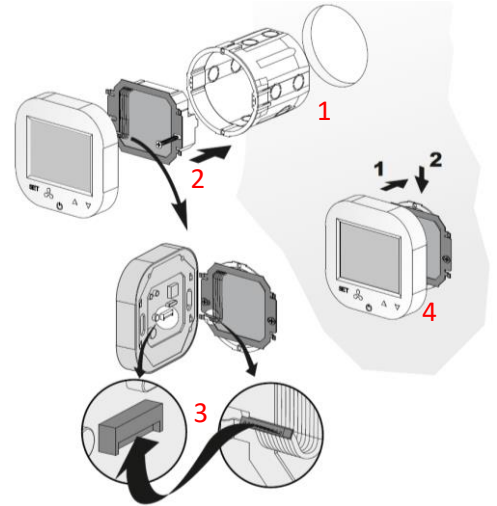

Figure 2 - VR-D Mini EC, VR-D EC connections

5.3. CONTROLLER FLUSH MOUNTING

Apply the following sequence of actions while flush-mounting of this controller:

- Install the flush mounted junction box (1)
- Cross all cables through the junction box and prepare their ends for plugging into controller's terminal block (remove the shields and apply end sleeves if justified)
- Plug the wires into the controller's terminal block according to relevant wiring diagram (above listed). Ensure that cables are properly plugged and are not loose.
- Install the rear power part of the controller in the flush mounted junction box and tight both sides screws (2)
- Plug the strip cable to the terminal in the front part of controller (3)
- Mount the front part of the controller on the rear one (4)



Caution. After all installation works, check if the flash mounting is properly done (the controller is fixed in the wall and is not loose).

5.4. OTHER INSTALLATION FACTS AND RECOMMENDATIONS

- Type of flush mounting junction box:
 - Flush mounted junction box Ø 60 mm, minimum depth of the box: 1-1,2"
- Flush mounted part of the controller:
 - Rear power supply unit
- Minimum height of the installation
 - 5 feet above floor level
- Minimum clearance between the controller (side edges of the front display part) and the surrounding parts of the fitment:
 - 4"
- The minimum dimensions of ventilating openings and their correct arrangements
 - N/A
- Power supply and communication wires
 - 6 x 18 AWG
 - Temperature of the wire insulation: 176 °F (80 °C)
- External temperature sensor wires
 - 2 x 20 AWG
 - Temperature of the wire insulation: 176 °F (80 °C)

Caution. After all installation works, check if the flash mounting is properly done (the controller is fixed in the wall and is not loose).

6. OPERATIONS ON THE HMI VOLCANO UL CONTROLLER

6.1. FRONT PANEL

The front panel of the HMI VOLCANO UL consists of the large display and set of buttons enabling full handling of the controller and the VOLCANO unit



Function of each button of the HMI VOLCANO UL controller are as per following description:

- LCD Screen – displays all information related with VOLCANO unit operations like status, calendar settings, alarm information etc.
- SET – approval of selected function of parameter
- Fan button – for easy toggling between available speeds of the fan revolutions
- On-Off button – main switch of the entire VOLCANO units
- Arrow up – toggles between the menu items in upwards direction
- Arrow down – toggles between the menu items in downwards direction

6.2. DISPLAY

The display of the HMI VOLCANO UL Controller consists of the following elements

Note: Some of the display elements are not in use for VOLCANO unit heaters. Table below show only elements specific for HMI VOLCANO UL system.

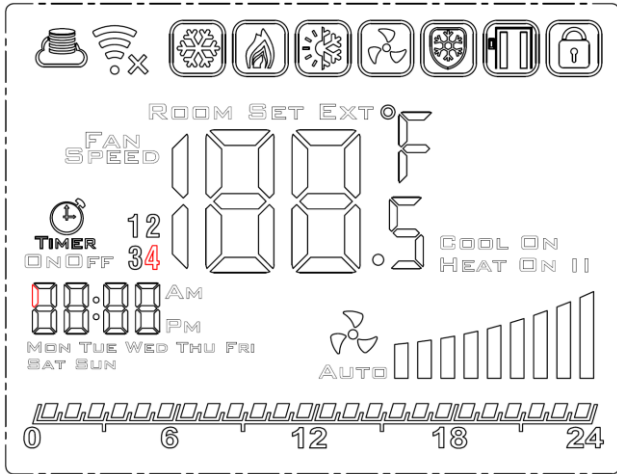

- Cooling mode indicator
- Heating mode indicator
- Ventilation mode indicator
- Water heater defrosting mode indicator
- Air temperature indicator
- Timer mode indicator
- Time indicator
- Day of the week indicator
- Keyboard lock indicator
- Fan status indicator
- Schedule chart

6.3. SWITCHING THE CONTROLLER ON AND OFF

Before attempting to any basic operations with this controller – you need to switch it on. To switch the controller on and off, press the on-off button (⏻), located below the display.

Keep in mind, that for modification of some advanced functions (advanced settings) you will start with the controller switched on (read the following chapters of this manual).

6.4. MAIN SETTINGS

No.	Description	Operation button
1	Fan operation mode: 1. AUTO: 2. MANUAL: AUTO	[^] or [v]
2	Calendar-based work: Yes TIMER ; ON No TIMER OFF	Function AA [^] or [v]
3	Operation mode: heating: ; cooling: ; ventilation ; heating + ventilation + ; cooling + ventilation +	Function A3 [^] or [v]

4	Temperature display: ROOM (current temp.), SET (set temp.) EXT (based on external temperature sensor) ROOM SET EXT 18.5	Function A1 [^] or [v]
5	Day of the week MON TUE WED THU FRI SAT SUN	Hold [Set]+[v]
6	Hour, minute 00:00 AM 00:00 PM	Hold [Set]+[v]
7	Screen lock	Hold [v]

Explanation of the operating modes:

- AUTO: Automatic operation mode
- MANUAL: the value set up by the user in a 15-100% scope. To change the value press () and set up value between 15-100% or 0% (stopping the fan) by using [+] and [-] buttons. Setting value lower than 15% will automatically set up value of 0%. Increasing value from 0% will automatically set up value of 15%.

Antifreeze protection of the water heater (): This function enables opening of the two way valve (of the water coil) in case of the air measured air temperature drastically drops. This function is active all the time (even for the unit in stop mode and regardless of

the schedule settings), as long the controller is energized with electric power

• heating (): heating mode;

• cooling (): cooling mode.

• ventilation (): ventilation mode.

• heating and ventilation mode ()

• cooling and ventilation mode ()

6.5. TIME SCHEDULE SETTINGS

6.5.1. TIME/DAY SETTING

You can set the present time and day on the controller. To do it, press and hold the [Set] button and the arrow down button. The

6.5.2. SCHEDULE SETTING

Having the controller in active mode, press the [Set] button and hold it for 5 seconds. The controller will enter the time (weekly) schedule settings mode.

Use the [Set] button to toggle between schedule functions [^] and [v] buttons to change the value.

The weekly schedule can be set for each day of the week and 4-time intervals for each day.

controller will enter the time/day settings mode allowing you to set present time and day of the week.

Your schedule settings will be demonstrated on the graphical time chart like on Figure 3



Figure 3 - Time schedule chart

7. PROGRAMMING MODE

7.1. ADVANCED SETTINGS, SECTION A

To enter the advanced settings A of this controller, press and hold the [] button for 5 seconds at the deactivated controller. Toggle between parameters using [Set] button. Change the value or settings of selected parameters using [^] and [v] buttons. After changes are applied, leave the settings mode by pressing power button of the controller. Your settings will be saved automatically. For advanced settings A group, the following parameters can be modified:

No.	Function	Set point
IP	Communication Modbus RTU - address	1 ... 247
A0	AntiFrost	ON/OFF
A1	Termostat/NTC10	Internal/external
A2	Temp. sensor calibration	max. $\pm 8^{\circ}\text{C}$ with the step of 0.5°C
A3	Heating/cooling/auto/ventilation	selection

Note. The Fan control signal offset settint (parameter A5 from above table) may be usefull for application in the larger spaces, where reachig of required air temperature is a problem. It is recommended to offset the fan control signal output as per below:

- 1,600 – 2,700 ft² - +1V (10%)

A4	Hysteresis of differential adjuster	0.5/1/2
A5	Fan control signal offset.	0, +1V, +2V, +3V, +4V
A6	Dynamic adjustment	1~3
A7	Buttons blockade	selection
A8	AntiFrost temperature	41 ... 77 °F (5....25 °C)
A9	Backlight time	5....600s
AA	Calendar-based work	No [0], Yes [1]
AB	Time mode	12h [1], 24h [0]
A0	Default settings	selection

- 1,600 – 2,700 ft² - +2V (20%)
- 2,700 – 6,500 ft² - +3V (30%)
- 6,500 ft² and more - +4V (40%)

Anytime you ned to disable the ran control signall output offset – set the parameter to 0V (0%)

7.2. ADVANCED SETTINGS, SECTION B

To enter the advanced settings B of this controller, press and hold the [Set] button for 5 seconds at the deactivated controller. Toggle between parameters using [Set] button. Change the value or settings of selected parameters using [^] and [v] buttons. After changes are applied, leave the settings mode by pressing power button of the controller. Your settings will be saved automatically. For advanced settings A group, the following parameters can be modified:

B0	Temperature units	°C/°F
B1	Min. Temperature	41 ... 104 °F (5....15 °C)
B2	Max. Temperature	61 ... 104 °F (16....40 °C)
B3	Communication Modbus RTU – speed	2400/4800/9600 kbps.
B4	Communicatin Modbus RTU – parity	None/ odd/ even

No.	Function	Set point
-----	----------	-----------

8. TECHNICAL SPECIFICATION

- Power supply
 - 1*120-230 VAC 60 Hz
- Power consumption
 - 1.5 VA
- Features of the automatic action
 - Type 1 Action, Type 1.B Action (UL 60730-1)
- Maximum current on relay outputs
 - 5 A (max 2.5 A on each circuit)
- Load type
 - Resistive, PF \geq 0.95
- RS485 port voltage / current limitation
 - -7... +12V / \pm 250 mA
- Temperature sensor type
 - NTC, 10 k Ω @ 77 °F (25 °C)
- Measured temperature range
 - 32 °F ... 122 °F, (0 °C ... 50 °C)
- Temperature measurement precision
 - \pm 0.9 °F (\pm 0.5 °C)
- Communication
 - Relay output: Dual - NO, 250 V, 5 A: 105 cycles, AgNi @ 85 °C; 5 x 104 cycles, AgSnO2 @ 85 °C
 - Analog output: 0-10V (8 bit, I_{max} = 20 mA)
 - Modbus RTU, 2400/4800/9600 bps,
- Working conditions limits
 - Temperature range: 32 °F ... 122 °F (0 °C ... 50 °C)
 - Relative humidity: 10-90% with no condensation.
- Storage conditions limits
 - Temperature range: -4 °F ... 122 °F (-20 °C ... 50 °C)
 - Relative humidity: 10-90% with no condensation.
- Ingress Protection
 - IP20
- Pollution Degree
 - 2
- Max working altitude
 - 6 000 ft (2 000 m) AMSL
- Construction and installation
 - Independently Flush-mounted. Flush Mount Junction Box, min 1-1,2" deep. Mounting bracket provided (a part of the controller assembly).
- Maximum mechanical load on the controller installation (flush-mounting)
 - Parallel to the the wall, downwards, both sides: 5 N
 - Parallel to the the wall, upwards (front panel unmounting direction), both sides: 2 N
 - Perpendicular to the wall: 5 N
- Dimension
 - 3-3/8" x 3-3/8" x 1-7/8" (86 x 86 x 48 mm)
- Weight
 - 5.3 oz (150 g).