

INSTALLATION INSTRUCTIONS:

1. Install threshold(s), if used, and fit and hang door(s).
2. Check that device handing matches door handing.
3. Tape full size RHR or LHR lock stile case and hinge stile case templates to inside face of door (Figure 1). Be sure center line of device is 39-13/16" from finished floor. Prepare inside face of door for device per templates.
4. Prepare lock stile of door for mortise lock (see mortise lock instructions 941019).
5. Prepare outside face of lock stile for trim (see trim instructions). Line X-X on trim instructions corresponds to line X-X on device template.
6. Prepare trim for installation (see trim instructions).
7. Install mortise lock (Figure 2).
8. For 1-3/4" thick doors, cut 3/8" off device lift finger.
9. Attach device cases to door (Figure 3).
10. Push down lock stile lever and check for full retraction of latch bolt. Release and check for full extension (3/4"). Adjust lift finger if necessary (Figure 4).
11. Measure dimension "X" (Figure 3) and cut crossbar tube to dimension "X." Cut end without hole.
12. Install crossbar tube and wedge assembly (see instructions 941009) and test crossbar for free action.
13. Prepare frame for strike (Figure 5).
14. Install strike to frame with two #12-12 x 12-24 x 1" combination screws.

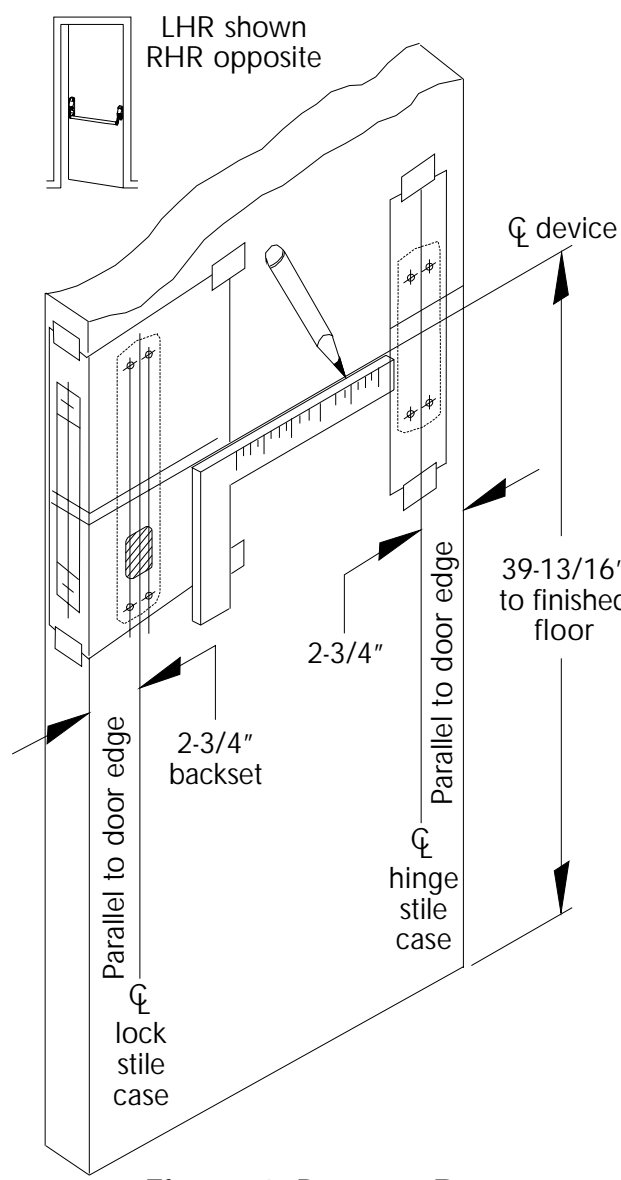

Figure 1. Prepare Door

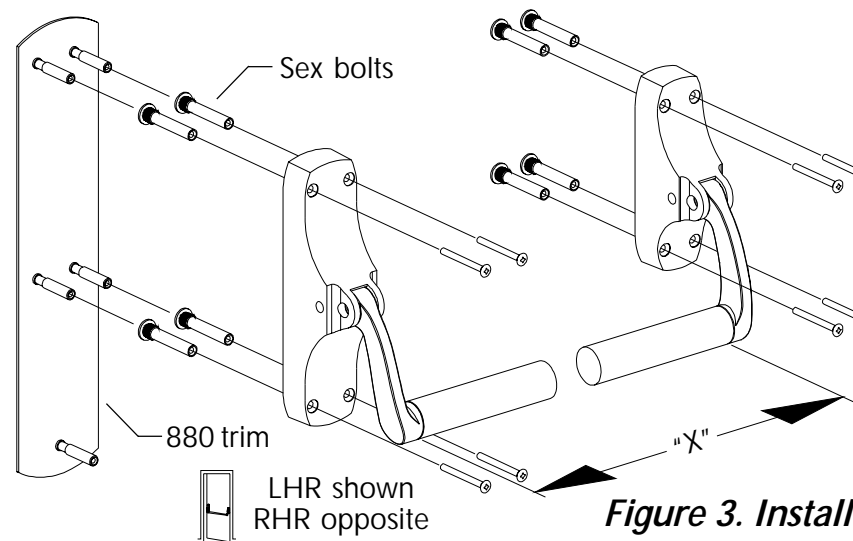
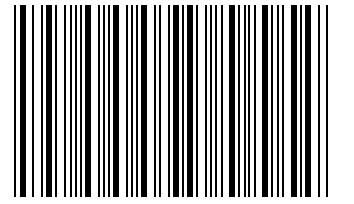

Figure 3. Install Device

Mounting	Fasteners
Surface	#10-12 x 10-24 x 2" combination screws (supplied with device)
880 trim	#10-24 machine screws
Sex bolts	#10-24 machine screws



911179-00

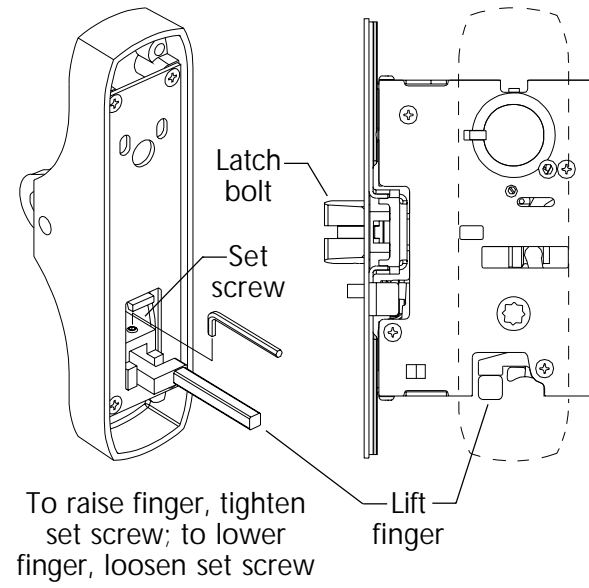

Figure 4. Adjust Lift Finger

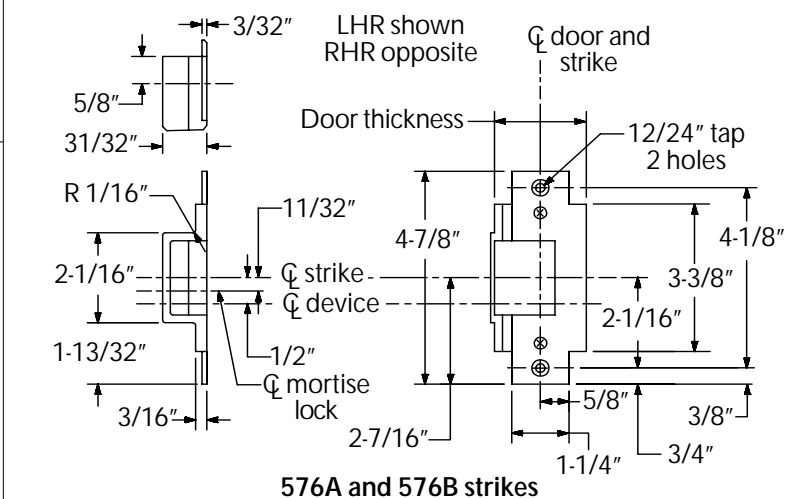
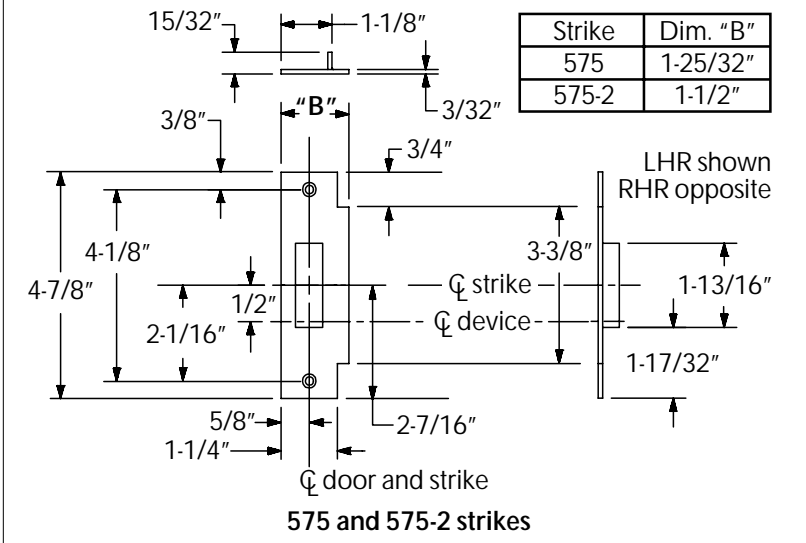
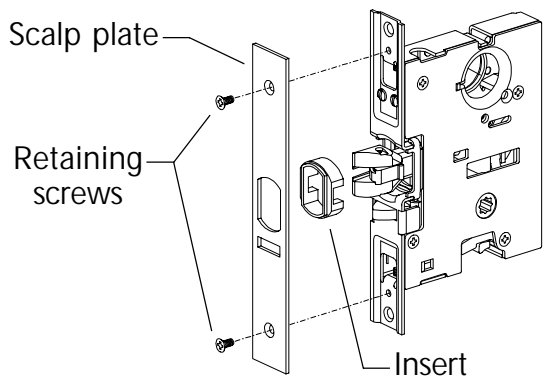

Figure 5. Prepare Frame for Strike

Figure 2. Install Mortise Lock

1. Remove retaining screws, scalp plate, and insert.



2. For TP and K trims turn NL screw clockwise all the way in.
3. Loosen top and bottom faceplate screws, pivot faceplate to match door bevel, tighten top and bottom faceplate screws.
4. Install mortise lock into door with two #12-12 x 12-24 combination screws.

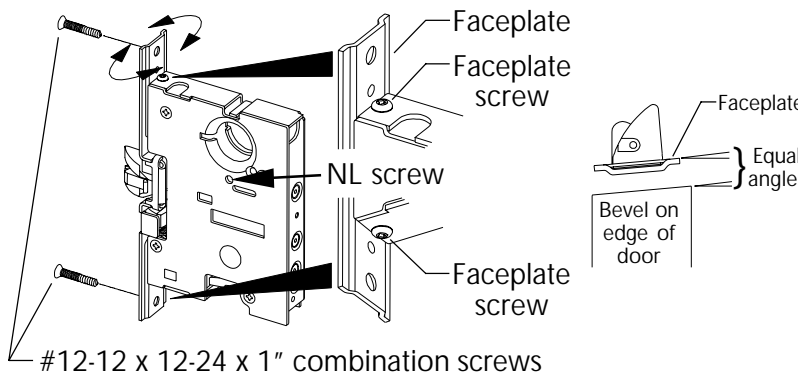

5. Rotate latch bolt so flat side faces exit direction.
6. Replace insert, scalp plate, and scalp plate retaining screws.

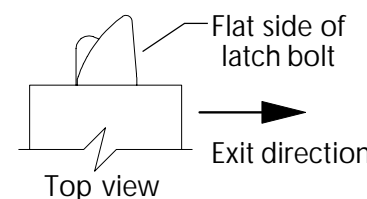

VON DUPRIN

DESCRIPTION:

8875 and 8875-F MORTISE LOCK DEVICES

Copyright © 2003 Ingersoll-Rand. All rights reserved.

IR VON DUPRIN

DIRECTION NUMBER:	SHEET#:	DATE:
911179_00(12)	1 of 1	01-01-03

CUT HERE

CUT HERE

CUT HERE

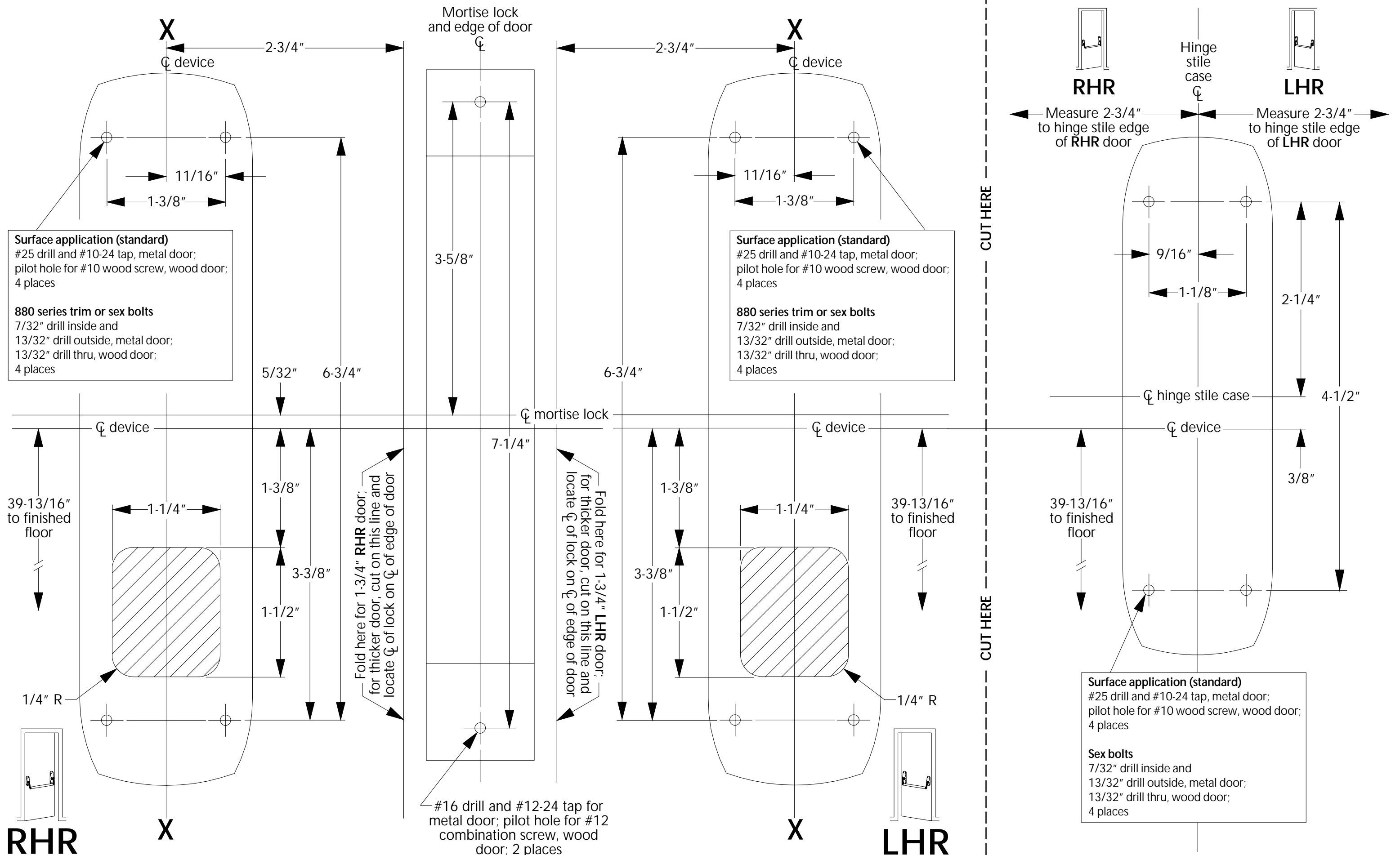

RHR

X

X

LHR

CUT HERE

CUT HERE

CUT HERE