

ASSEMBLY INSTRUCTIONS

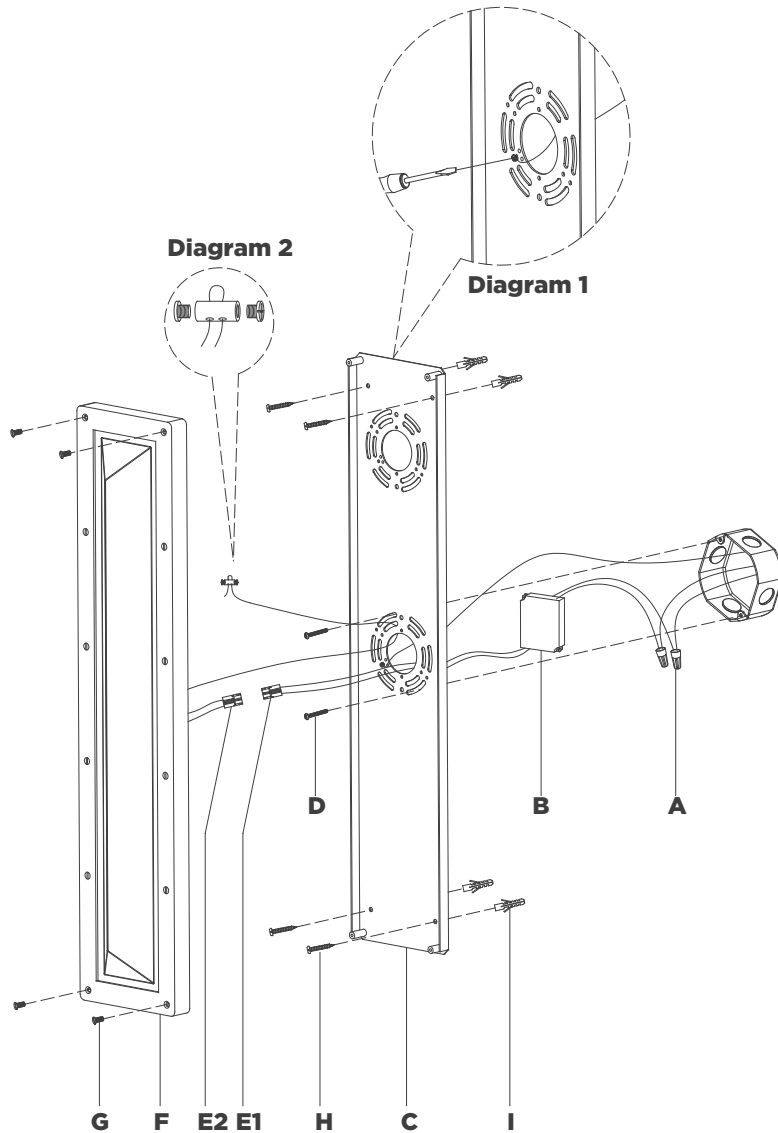

Rolland 27" Sconce

Item # RL2616

NOTICE:

This light fixture should be installed in accordance with all applicable, local installation codes, and by a person familiar with the construction and operation of it, as well as the hazards involved. Inspect item and contents carefully. If any damage or defect is found, do not install. Retain all packaging material until installation is complete and approved.

TOOLS REQUIRED (NOT INCLUDED):

Phillips Screwdriver	Slotted Screwdriver	Hammer
Pencil	Drill	

1. Carefully remove all parts from the box. Place on a clean, soft surface.
2. Remove mounting plate **(C)** from fixture **(F)** by removing screws **(G)**.
3. Using mounting plate **(C)** as a guide, line up with the junction box and mark anchor positions.
4. Using a drill bit slightly smaller than the anchor, drill holes in the marked positions. Install anchors **(I)** into the holes using a hammer.
5. Wrap supply ground wire (usually green or bare copper) around the green grounding screw (see diagram 1). Tighten.
NOTE: It is imperative that the fixture is grounded.
6. Connect driver **(B)** input neutral wire (white) to the supply neutral wire (usually white) using wire nut **(A)**.
7. Connect driver **(B)** input hot wire (black) to the supply hot wire (usually black) using wire nut **(A)**.
CAUTION: Do not reverse the hot and neutral connections.
8. Make sure all wire connections are tight, then carefully tuck into the junction box.
9. Insert driver **(B)** into junction box.

RALPH LAUREN



ASSEMBLY INSTRUCTIONS

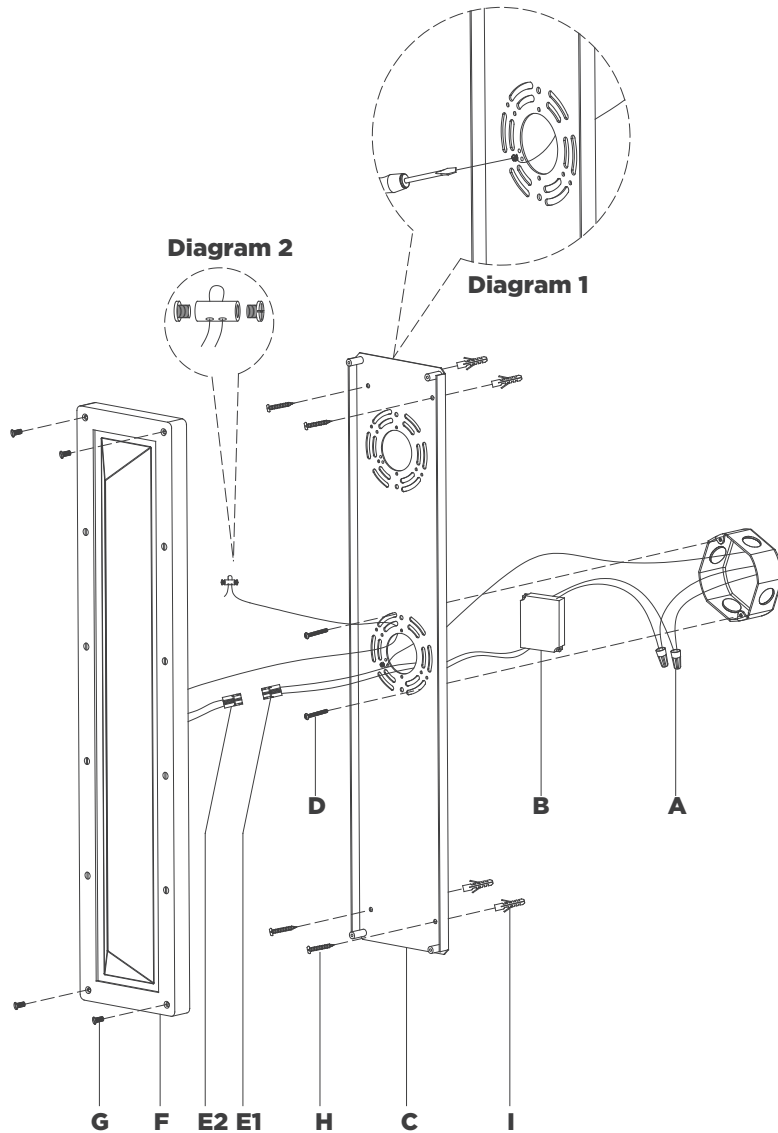

Rolland 27" Sconce

Item # RL2616

NOTICE:

This light fixture should be installed in accordance with all applicable, local installation codes, and by a person familiar with the construction and operation of it, as well as the hazards involved. Inspect item and contents carefully. If any damage or defect is found, do not install. Retain all packaging material until installation is complete and approved.

10. Install mounting plate (C) to the junction box and secure with mounting screws (D), then secure wood screws (H) to anchors (I).
11. Run support cable through hole on back of mounting plate (C). Loosen cable lock and install to end of support cable. Insert other end of cable through the cable lock and tighten ends with a screwdriver to secure (see diagram 2).
12. Connect quick connectors (E1) & (E2) together.
13. Install fixture (F) to mounting plate (C) and secure with screws (G).

FOR OUTDOOR/WET LOCATION INSTALLATION:

14. Using silicon compound, apply a small bead where backplate meets the wall to prevent water from entering.

NOTE: Large gaps will need to be corrected before applying silicon compound.

CARE INSTRUCTIONS: Clean only with a soft dry cloth or feather duster. Do not use abrasive or chemical agents.

RALPH LAUREN

