

Captra Pendant

700FJCPT_

1.0

VISUAL COMFORT & Co.

ARCHITECTURAL COLLECTION

GENERAL PRODUCT INFORMATION:



This product is ETL listed and suitable only for indoor dry locations and approved for use at any height above the finished floor.

This product is patented (U.S. PAT. 6,183,297).

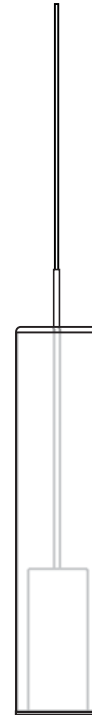

Adjust The Fixture Height

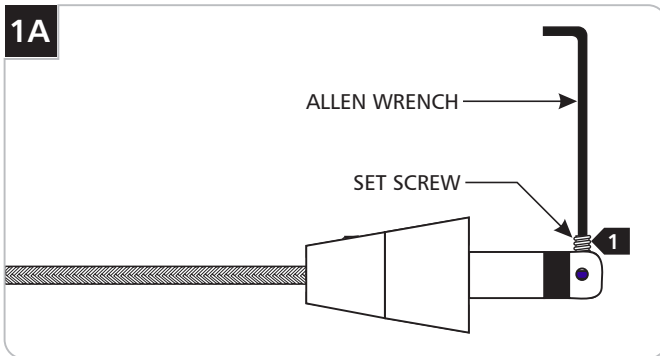

1 Back out (do not remove) the set screw on tip of the connector with the provided Allen wrench.

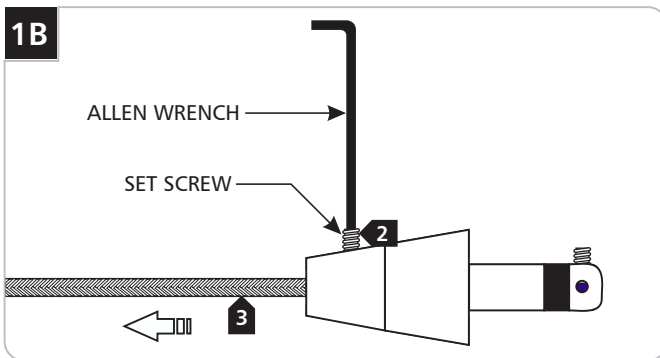

2 Back out (do not remove) the set screw on the conical connector with the provided Allen wrench.

3 Pull the coaxial cable out.

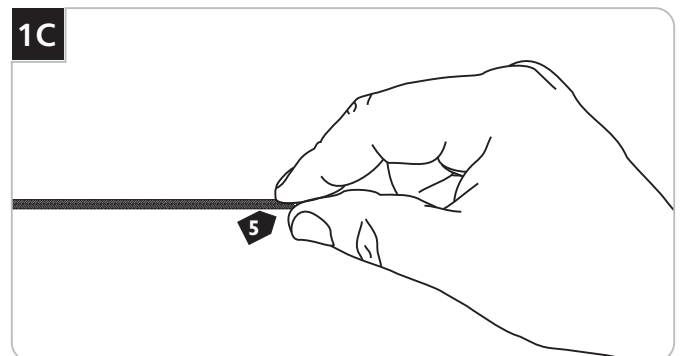

4 Cut the coaxial cable to the desired length.

5 Gently twist the end of the coaxial cable between thumb and forefinger.

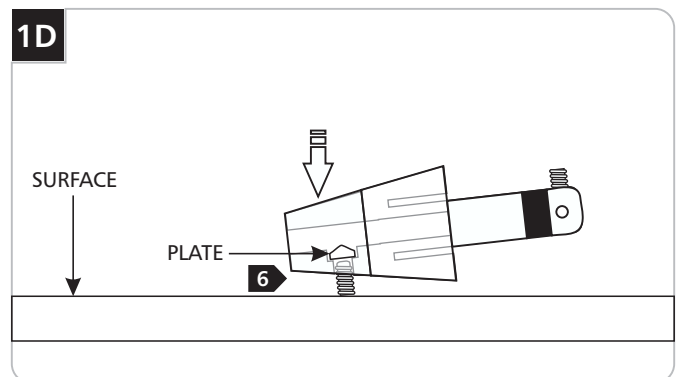

6 Tap the conical connector on a hard surface with the set screw facing down, so the plate inside drops into place.

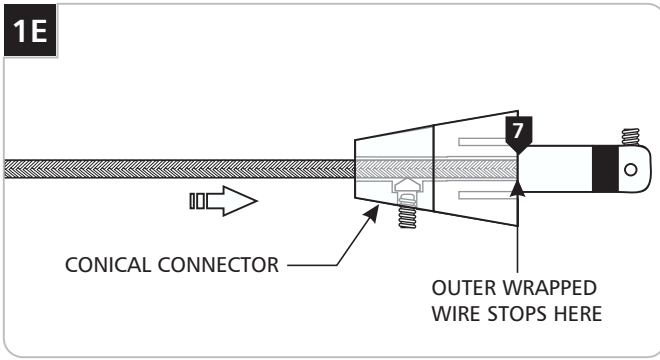

7 Feed and push the coaxial cable into the conical connector. The coaxial cable will come to a stop point after being inserted 3/4" into the conical connector.

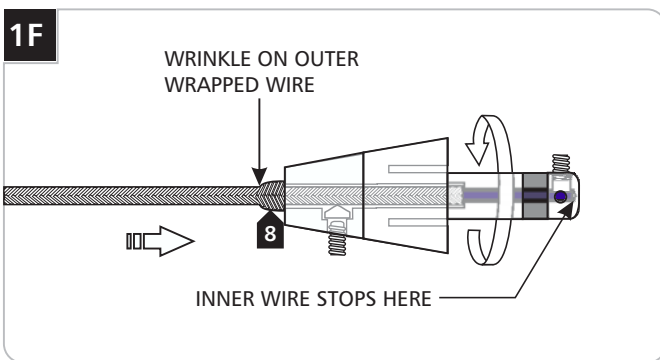

8 Keep pushing the coaxial cable into the connector while rotating the connector to ease feeding the inner wire into the tip of the connector. The outer wrapped wire will start wrinkling while being inserted another 1/2" into the connector.

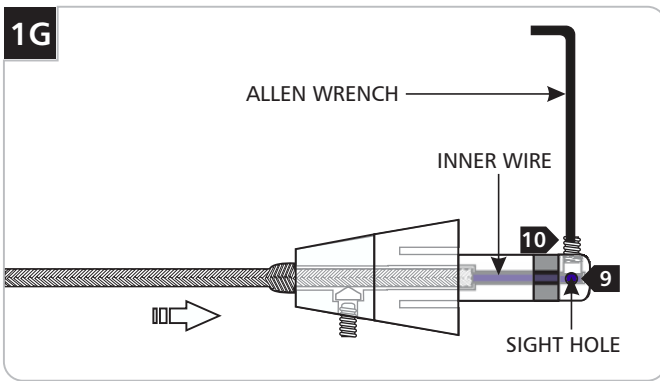

9 Look into the sight hole on the top of the connector to make sure that the inner wire is contacting the end of the connector.

10 Hold the coaxial cable in place and tighten the set screw on top of the connector with the provided Allen wrench. ***Make sure this set screw connection is tight.***

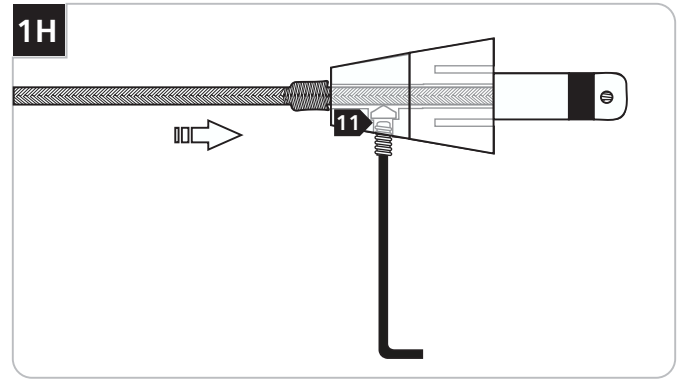

11 Firmly tighten the set screw on the conical connector.

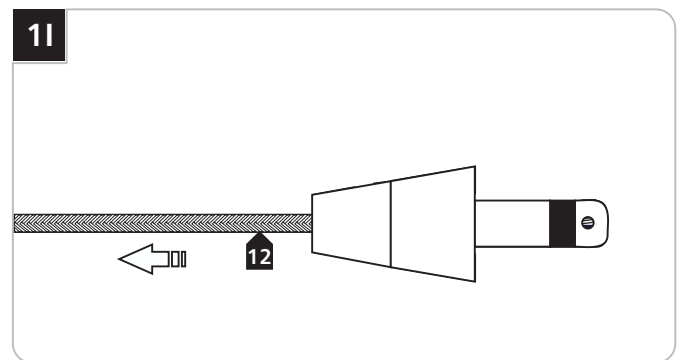

12 Pull the coaxial cable toward the fixture to smooth the wrinkles.

Replacing the Lamp

CAUTION: To reduce the risk of a burn or electric shock during relamping, disconnect the power to the fixture.

2A

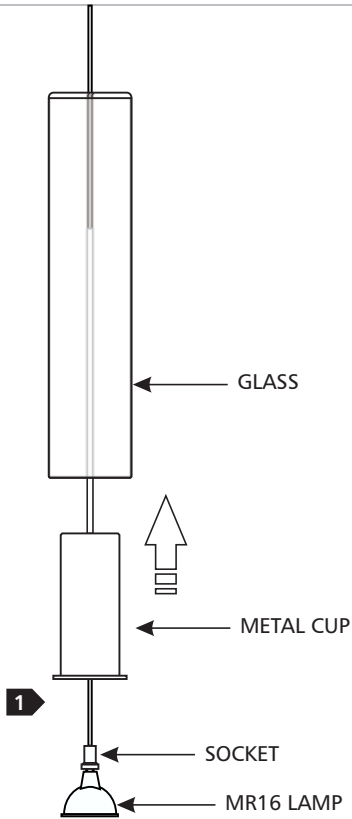

1 Move the fixture glass and metal cup up to expose the socket.

2B

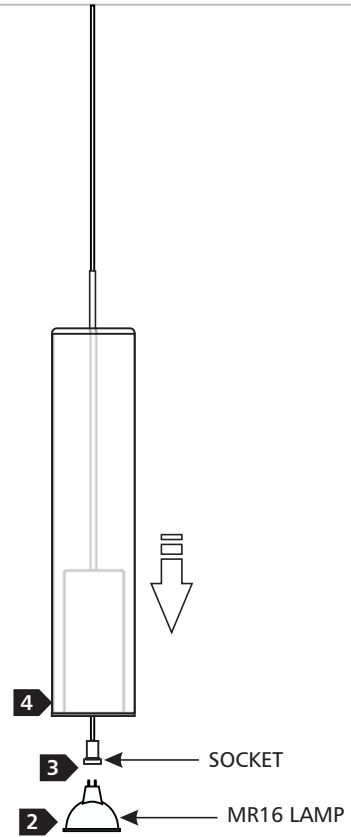

For incandescent versions, use **MAX 35 Watt** Mr16 Front Cover Halogen lamp.



For LED versions, use provided **MAX 8 Watt LED** MR16 Bi-Pin Lamp.

- 2** Remove the old lamp.
- 3** Push the new lamp pins completely into the socket.
- 4** Lower the glass and metal cup back on top of the socket assembly.

SAVE THESE INSTRUCTIONS!