

MonoRail Flexible Connectors

DESCRIPTION

These conductive connectors join sections of rail together end to end at desired sharp horizontal angle. Pair.

WEIGHT

0.1lb / 0.05kg ±

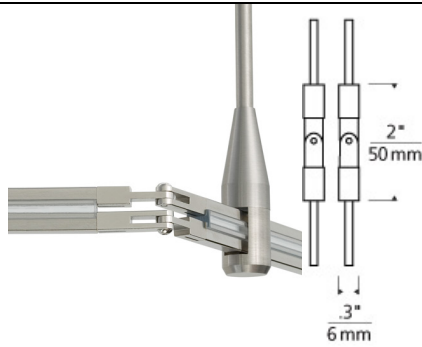

monorail flexible connectors

ORDERING INFORMATION

700MOCFXH FINISH

- Z ANTIQUE BRONZE
- S SATIN NICKEL



TECH LIGHTING®

7400 Linder Avenue T 847.410.4400
Skokie, Illinois 60077 F 847.410.4500

Tech Lighting, L.L.C.

700MOCFXH _____
FIXTURE TYPE: _____
JOB NAME: _____
NOTES: _____

