

Bau 50 Linear Suspension LED

DESCRIPTION

The Bau Linear Suspension by Tech Lighting draws attention to the glow of integrated LEDs nested within thin rounded metal stamped plates. Celebrating the modern influence of Asian design, LED-firing fins provide generous illumination to any space. Available in two modern finishes Nightshade Black and Natural Brass that will patina over time, the Bau Linear Suspension is a stunning focal point to your interior design. Complete the look with Line Voltage Pendants and Bath Bar. Includes 59.6 watts, 2819 total delivered lumens, 3000K LED modules. Dimmable with most LED compatible ELV and TRIAC dimmers. Includes (8) 12" and (4) 6" rigid stems in coordinating finish.

INSTALLATION

This product can mount to either a 4" square electrical box with round plaster ring or an octagonal electrical box (not included).

WEIGHT

41-41lb / 18.6-18.6kg ±

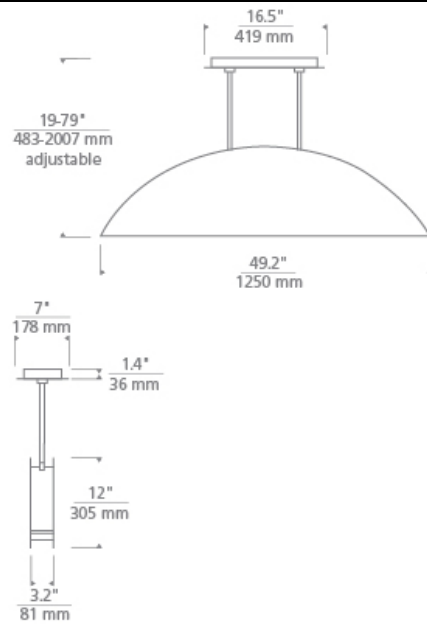

natural brass nightshade black

ORDERING INFORMATION

700LSBAU50 FINISH

LAMP

NBNATURAL BRASS

-LED930 INTEGRATED LED 90 CRI 3000K 120V



700LS BAU50

FIXTURE:

TYPE:

JOB NAME:

NOTES:

