

# BAU 50 LINEAR SUSPENSION

VISUAL COMFORT & Co.

## PRODUCT FEATURES

- Influenced by the Bauhaus movement, generously sized geometric metal stamped plates house integrated LEDs providing a generous amount of indirect illumination to any space
- Modern finishes available
- Complete the look with Line-Voltage Pendants and Bath Bar
- Includes two sets of (2) 6" and (4) 12" rigid stems. Due to weight, J-Box must hold a minimum of 150 lbs
- This item is made of natural brass. It is a living finish that will patina and warm with age which adds richness. If it gets an uneven patina or spots, a brass cleaner can restore the finish
- Protected by a 5-year warranty. Please visit the "About Us" Page on [techlighting.com](http://techlighting.com) for more for warranty details



## LAMPING

Includes 58.3 watts, 1211 total delivered lumens, 3000K LED modules. Dimmable with most LED compatible ELV and TRIAC dimmers. Includes (8) 12" and (4) 6" rigid stems in coordinating finish. Can be installed on a sloped ceiling up to 20°.

Nightshade Black



Nightshade Black

Nightshade Black  
3/4

Natural Brass

Natural Brass 3/4

## ORDERING INFORMATION

700LSBAU50 FINISH

NB NATURAL BRASS  
B NIGHTSHADE BLACK

LAMP

-LED930 INTEGRATED LED 90 CRI 3000K 120V

700LSBAU50

JOB NAME

NOTES



© 2019 Tech Lighting, L.L.C. All rights reserved. The "Tech Lighting" graphic is a registered trademark of Tech Lighting, L.L.C. Tech Lighting reserves the right to change specifications for product improvements without notification.

7400 Linder Avenue, Skokie, IL 60077  
T 847.410.4400 | F 847.410.4500 | [techlighting.com](http://techlighting.com)

# BAU 50 LINEAR SUSPENSION

VISUAL COMFORT & Co.

## SPECIFICATIONS

PRIMARY MATERIAL	Aluminum
SHADE MATERIAL	Aluminum
NET WEIGHT	41 lbs
HEIGHT	12in
WIDTH	3.2in
LENGTH	49.2in
UP LIGHT / DOWN LIGHT / BOTH?	
WET LISTED	
DAMP LISTED	
DRY LISTED	
MIN. HANGING HEIGHT	19.7in
MAX HANGING HEIGHT	73.7in
TOTAL CORD LENGTH	
TOTAL STEM LENGTH	Up to 120in
STEM QTY	12
SLOPED CEILING ADAPTABLE?	Yes 20° Max
GENERAL LISTING	ETL Listed
INCLUDES	

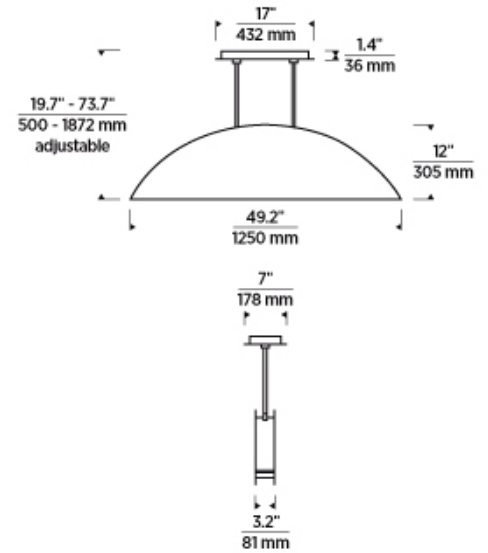

## LAMPING SPECIFICATIONS

	LED LAMP	INTEGRATED LED	NON LED	NO LAMP
DELIVERED LUMENS		1211		
WATTS		58.3		
MAX WATTAGE PER BULB		58.3W		
		120V ELV, TRIAC		
CCT		3000K		
CRI		90 CRI		
LED LIFETIME		>50000		
L70				
AVERAGE BULB HOURS				
FIELD SERVICEABLE LED				
LAMP BASE		Integrated LED		
LAMP SHAPE		Integrated LED		
LAMP INCLUDED?		True		
WARRANTY**		5 Years		

\* Dimming information available at [www.techlighting.com/Downloads#dimming](http://www.techlighting.com/Downloads#dimming)

\*\* Visit [techlighting.com](http://techlighting.com) for specific warranty limitations and details.

## T20 / T24 / JA8 INFORMATION

	Integrated LED	Replacement LED Lamp	No Lamp *
This product can be used to comply with California Building Energy Efficiency Standards 2016 Title 24 Part 6 / JA8.	No		
This product can be used to comply with California Appliance Efficiency Standards 2016 Title 20 and may be shipped to and sold in California.	N/A		

\* If a light fixture or component does not include a lamp or light source, it is the responsibility of the customer to select a lamp that meets the T24 and T20 requirements.

