

Bau 24 Bath LED ADA

DESCRIPTION

The Bau 24 Bath by Tech Lighting emits a beautiful glow of integrated LEDs nested between thin metal plates. The clean aesthetic is modern influence of Asian-design, four LED-firing fins provide generous illumination to any space. Available in three modern finishes Nightshade Black, Polished Nickel and Natural Brass that will patina over time, the Bau Line Voltage pendant is a stunning focal point to your interior design. Complete the look with Line Voltage Pendants and Linear Suspension. Includes 120 volt 9.8 watt, 870 delivered lumens, 3000K LED module. 120V dimmable with most LED compatible ELV and TRIAC dimmers. 277V compatible with 0-10V dimmers. Mounts horizontally or vertically. ADA compliant.

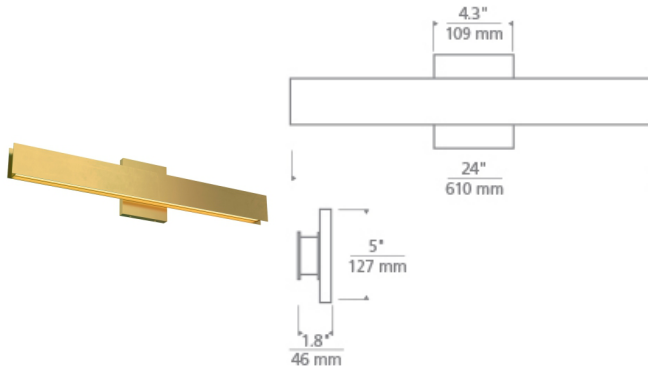

INSTALLATION

This product can mount to either a 4" square electrical box with round plaster ring or an octagonal electrical box (not included).

WEIGHT

3.5-3.5lb / 1.59-1.59kg ±



natural brass nightshade black polished nickel

ORDERING INFORMATION

700BCBAU	LENGTH (A)	FINISH	LAMP
24	24"	N NATURAL BRASS B NIGHTSHADE BLACK N POLISHED NICKEL	-LED930 LED 90 CRI 3000K 120V -LED930-277 INTEGRATED LED 90 CRI 3000K 277V -LED930-277 LED 90 CRI 3000K 277V



700BC BAU

FIXTURE

TYPE:

JOB NAME:

NOTES: