

A PROUD HERITAGE OF EXPERIENCE & QUALITY

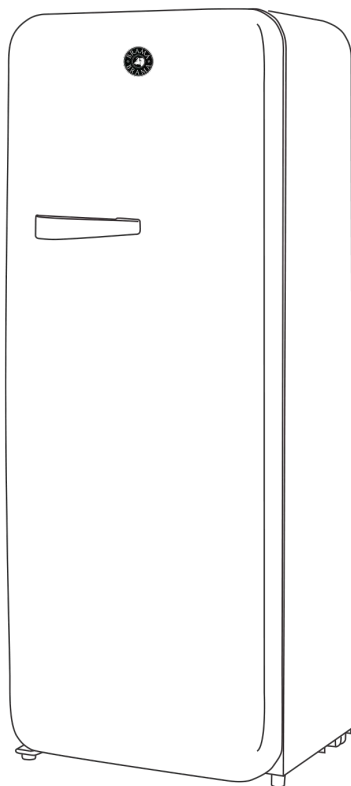

REFRIGERATOR

BR-RETRO-01-R, BR-RETRO-01-W, BR-RETRO-01-BLK

OWNER'S MANUAL



WWW.VINOTEMP.COM



A PROUD HERITAGE OF EXPERIENCE & QUALITY

PRODUCT REGISTRATION

Purchase Confirmation

With the information you provide, we can confirm the date of purchase for your product. The confirmation is of benefit to you, especially if your original proof of purchase is lost.

Product Registration

Completing this product registration is the only way to guarantee you will be notified of substantive issues that arise concerning your product.

Become a Member of the Vinotemp® Family

Complete this product registration with your e-mail address and receive special offers and updates on new products via e-mail.

**IMPORTANT:
Complete your product registration today!**

Visit product and warranty registration at:
<https://www.vinotemp.com/extended-warranty/register-warranty>

For more information on warranty service and repair, please refer to the appropriate section of your product literature.

For additional information about Vinotemp product, visit www.vinotemp.com or call toll-free 1-800-777-8466

Please also fill out the Questionnaire below for a chance to receive a FREE GIFT.

<https://www.vinotemp.com/product-registration-form>



GENERAL OPERATING INSTRUCTIONS

Remove all external and internal packaging from your appliance. Be sure that all parts have been included before discarding any packaging materials. You may want to keep the box and packing materials for use at a later date.

Upon receipt and inspection of unit, the supply cord must be replaced if it is damaged. Contact our customer service at 1-800-777-8466 or info@vinotemp.com.

Let the unit rest UNPLUGGED for 24 hours once you have it placed in your home.

READ ALL INSTRUCTIONS BEFORE USING THIS APPLIANCE
-Save these instructions-

To register your product, visit: <http://www.vinotemp.com>
Register your warranty within 10 days of receiving the unit.
Please be sure to retain your proof of purchase.

Protect Your Investment with an Extended Warranty!



Add a New Leaf extended warranty to your order, and have the security of knowing that if there should be a problem, even years in the future, New Leaf will be there to assist! Usable for any Wine Cellar or other electronic device manufactured by Vinotemp. Add this warranty to purchases made from vinotemp.com or other qualified vendors. Warranty must be registered within the first 10 days from original purchase.

Visit www.vinotemp.com to purchase.

State of California Proposition 65 Warnings:

WARNING: This product can expose you to chemicals including BPA, Styrene, Nickel (Metallic) as well as some other products listed in the Prop 65 list used in making our appliances, which is known to the State of California to cause cancer and reproductive harm.

For more information go to www.P65Warnings.ca.gov

TABLE OF CONTENTS

IMPORTANT SAFETY INSTRUCTIONS	5
USAGE CONDITIONS AND RESTRICTIONS	6
REFRIGERANT GAS WARNINGS	7
GENERAL SAFETY	8
PARTS LIST AND SPECIFICATIONS	10
GETTING STARTED	12
DOOR HANDLE INSTALLATIONS	12
INSTALLATING THE REFRIGERATOR	14
SETTING THE TEMPERATURE CONTROL	15
DEFORSTING	16
TOUCH PANEL TEMPERATURE SETTING	18
FOOD STORAGE AND ENERGY SAVING TIPS	19
CARE AND MAINTENANCE	20
TROUBLESHOOTING GUIDE	23
TERMS AND CONDITIONS	25
SERVICE & IMPORTANT NOTICE	34



Important Safeguards

READ ALL INSTRUCTIONS

Read this manual thoroughly before first use, even if you are familiar with this type of product. The safety precautions enclosed herein reduce the risk of fire, electric shock and injury when correctly adhered to. Keep the manual in a safe place for future reference, along with the completed warranty card, purchase receipt and carton. If applicable, pass these instructions on to the next owner of the appliance. Always follow basic safety precautions and accident prevention measures when using an electrical appliance, including the following:

Electrical safety and cord handling

- Make sure your outlet voltage and circuit frequency correspond to the voltage stated on the appliance rating label. If this is not the case, contact the after sales support line and do not use the refrigerator.
- Do not use any other appliance at the same time on the same electrical circuit as it may overload the circuit and blow the fuse or circuit breaker.
- To protect against fire and electric shock, do not immerse the cord, plug, power base or the Retro Under Counter Fridge body itself in water or other liquid. Do not expose the electrical connections to water.
- The cord should be run in such a way that there will be no risk of anyone pulling it inadvertently or tripping over it.
- Do not kink, bend, squash, strain or damage the power cord and protect it from sharp edges and heat.
- Grip the plug when disconnecting, do not pull the cord.
- Do not let the cord hang over the edge of a table or bench top. Do not let it touch hot surfaces.
- Do not pick up or operate the appliance if the power supply cord or plug is damaged, or after it malfunctions or has been dropped or damaged in any way.
- In case of damage, contact the after sales support line for advice.
- A damaged cord or plug must be replaced by the manufacturer or a qualified person in order to avoid a hazard.
- Make sure all electrical connections are clean and dry before switching on.
- Do not use this appliance in conjunction with an extension cord.
- Unplug the appliance from the power outlet when not in use and before cleaning, servicing, maintenance or moving the appliance.
- This appliance is not intended to be operated by means of an external timer or separate remote control system.

Usage conditions and restrictions

- This appliance is intended for domestic use only.
- This product is not intended for commercial use. Do not use it outdoors.
- Only use this refrigerator as described in this manual. Any other use is not recommended and may cause fire, electric shock or injury.
- Improper installation and the use of accessories not recommended by the appliance manufacturer may result in fire, electric shock or personal injury and will invalidate your warranty.
- We assume no responsibility for any eventual damages caused by improper or faulty use.
- This appliance is not intended for use by persons (including children) with reduced physical, sensor or mental capabilities, or lack of experience and knowledge, unless they have been given supervision or instruction concerning use of the appliances by a person responsible for their safety.
- Children should be supervised to ensure they do not play with the appliance.
- Close supervision is necessary when any appliance is used by or near children.
- Do not use chemical, steel wool or abrasive cleaners to clean the outside of the unit, as these will scratch the metal surface.
- Do not operate the unit near liquids (kitchen sink, water basins, taps etc).
- Ensure that all the parts are correctly assembled before operation.
- Maintain the appliance in accordance with the instructions to ensure that it functions properly.
- If there is a product malfunction, or if it has been damaged in any way, call the after sales support for assistance.
- Immediately unplug the appliance if fire or smoke is emitted.
- Place the product on a straight, rigid and stable surface, away from sources of direct sunlight or excessive heat.
- Do not place the product near heat sources such as radiators, heat registers, stoves or other appliances that produce heat.
- Do not place the product near other items that may damage it, such as naked flame sources (lit candles) or objects containing water (a vase or fish bowl).
- Take care that no objects fall and no liquids are spilled into any openings.



WARNING!

- **Prevent overheating:** Place the product in a sufficiently aerated place. Ensure that air can circulate freely around the back of the refrigerator. To ensure best performance, leave a distance of about 100mm to all sides of the fridge.
- This appliance features a short power cord to reduce the risk of being entangled, and to reduce the risk of tripping. An extension cord or longer detachable cord is not recommended for use with this product.
- There are no user-serviceable parts inside. Do not attempt to service this product. Please call our after sales support for instructions.

FLAMMABLE - REFRIGERANT GAS WARNINGS

 **Danger!** Risk of fire or explosion. Flammable refrigerant used. To be repaired only by trained service personnel. Do not puncture refrigerant tubing.

Safety information

 **Caution!** Risk of fire or explosion. Flammable refrigerant used. Consult repair manual/owner's guide before attempting to service this product. All safety precautions must be followed.

 **Caution!** Risk of fire or explosion. Dispose of property in accordance with federal or local regulations. Flammable refrigerant used.

 **Caution!** Risk of fire or explosion due to puncture of refrigerant tubing; follow handling instructions carefully. Flammable refrigerant used.

- The refrigerant isobutane (R600a) is contained within the refrigerant circuit of the appliance, a gas with a high level of environmental compatibility, which is nevertheless flammable. During transportation and installation of the appliance, ensure that none of the components of the refrigerant circuit become damaged.
- **WARNING: Do not damage the refrigerant circuit! Never use an appliance with a damaged refrigerant circuit!** If the refrigerant circuit becomes damaged, avoid proximity to open fires and all types of heat and ignition sources. Thoroughly ventilate the room in which the appliance is located.
- It is hazardous for anyone other than an authorised service person to service this appliance.
- The room for installing the appliance must be at least 1m³ per 8g of refrigerant. The amount and type of refrigerant in the appliance can be found in the Technical Specifications.

General safety

WARNING!

Do not use other electrical appliances (such as ice cream makers) inside of refrigerating appliances, unless they are approved for this purpose by the manufacture.

- Do not store explosive substances such as aerosol cans with a flammable propellant in this appliance.
- During transportation and installation of the appliance, be certain that none of the components of the refrigerant circuit are damaged.
- Avoid open flames and sources of ignition.
- Thoroughly ventilate the room in which the appliance is situated.
- It is dangerous to alter the specifications or modify this product in any way.
- Any damage to the cord may cause a short circuit, fire and/or electric shock.

WARNING!

- **This appliance is heavy.** Care should be taken when moving it. To avoid back or other injury, consider a two person lift or mechanical aid when installing it. Failure to do so can result in back or other injury.
- Avoid prolonged exposure of the appliance to direct sunlight.
- This appliance is intended to be used in household only.

WARNING!

- Any electrical components (plug, power cord, compressor and etc.) must be replaced by a certified service agent or qualified service personnel.
- **DO NOT USE AN EXTENSION CORD.** Use an exclusive wall outlet. Do not connect your refrigerator to extension cords or in an outlet used by any other appliance.
- Make sure that the power plug is not squashed or damaged by the back of the appliance. A squashed or damaged power plug may overheat and cause a fire.

Safety information

- Before first use, it is advisable to wait at least eight hours before connecting the appliance to allow the oil to flow back in the compressor.
- Adequate air circulation should be around the appliance, lacking this leads to overheating. To achieve sufficient ventilation follow the instructions relevant to installation.
- The appliance must not be located close to radiators or cookers.
- Make sure that the mains plug is accessible after the installation of the appliance.

Daily use

- Do not put **hot** food in the appliance.
- Store pre-packed food in accordance with the food manufactures instructions.
- **WARNING!** Do not use mechanical devices or other means to accelerate the defrosting process. Never use a sharp or metal instrument to remove frost or clean the appliance. Use a plastic scraper, if necessary.
- Appliance storage recommendations should be strictly adhered to. Refer to relevant instructions.
- If the refrigerator is unplugged, turned off or has lost power, you must wait 3 to 5 minutes before restarting the unit. If you attempt to restart before this time delay, the refrigerator will not start.

SAVE THESE INSTRUCTIONS

SPECIFICATIONS

Model	BR-RETRO-01-R, BR-RETRO-01-W, BR-RETRO-01-BLK
Voltage	AC 110V
Frequency	60Hz
Cooler Temp Range	32 - 50°F (0 to 10°C)
Freezer Temp Range	-13 - 5°F (-25 to -15°C)
Refrigerant	R600a
Power Consumption	248kw/h
Defrost Power	No Defrost
Volume (L)	281L
Net Weight	127.9lbs (58kg)
Gross Weight	143.3lbs (65kg)
Dimensions (W x D x H)	24.02 x 24.4 x 60 in
Box Dimensions (W x D x H)	27.56 x 27.96 x 62.79 in

PARTS LIST

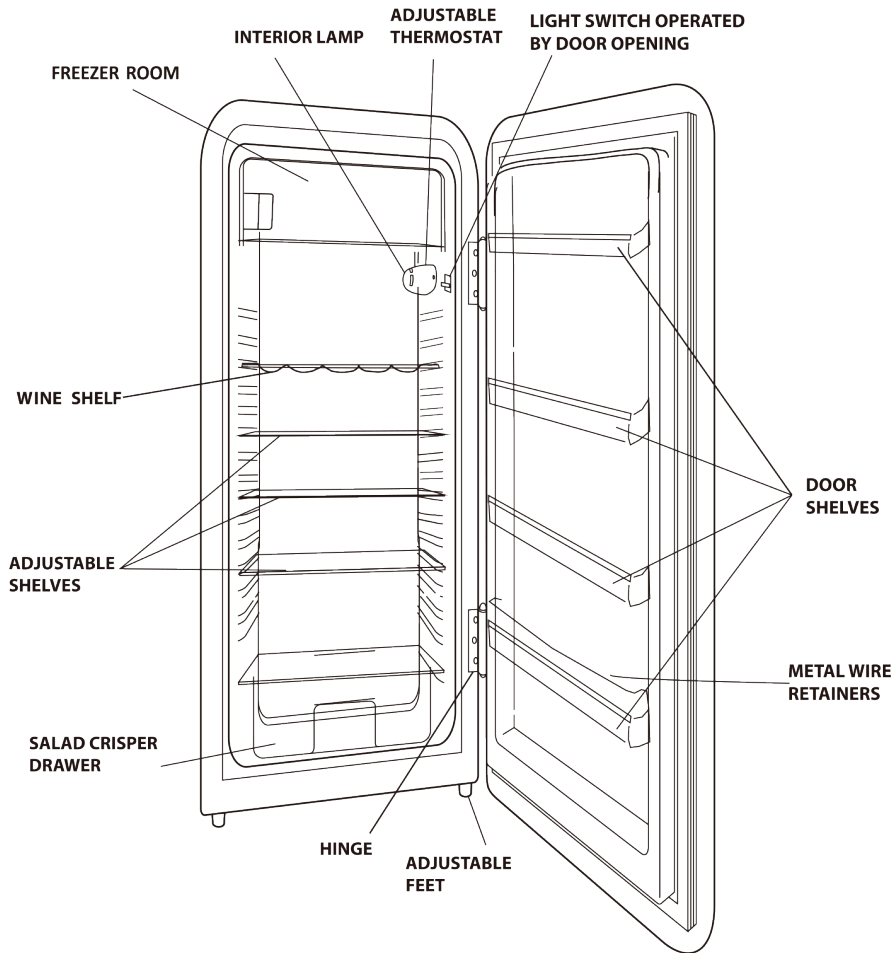

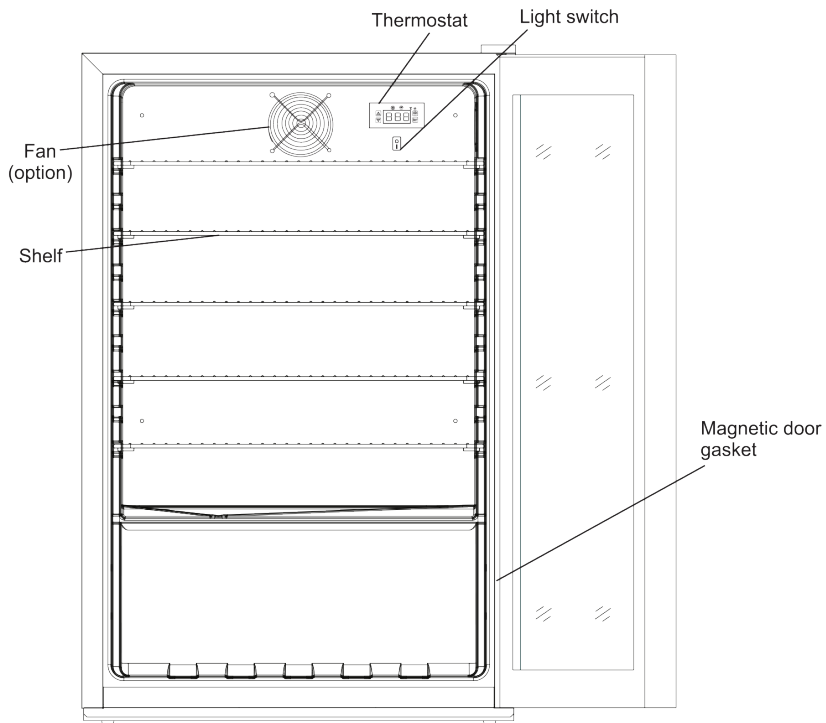
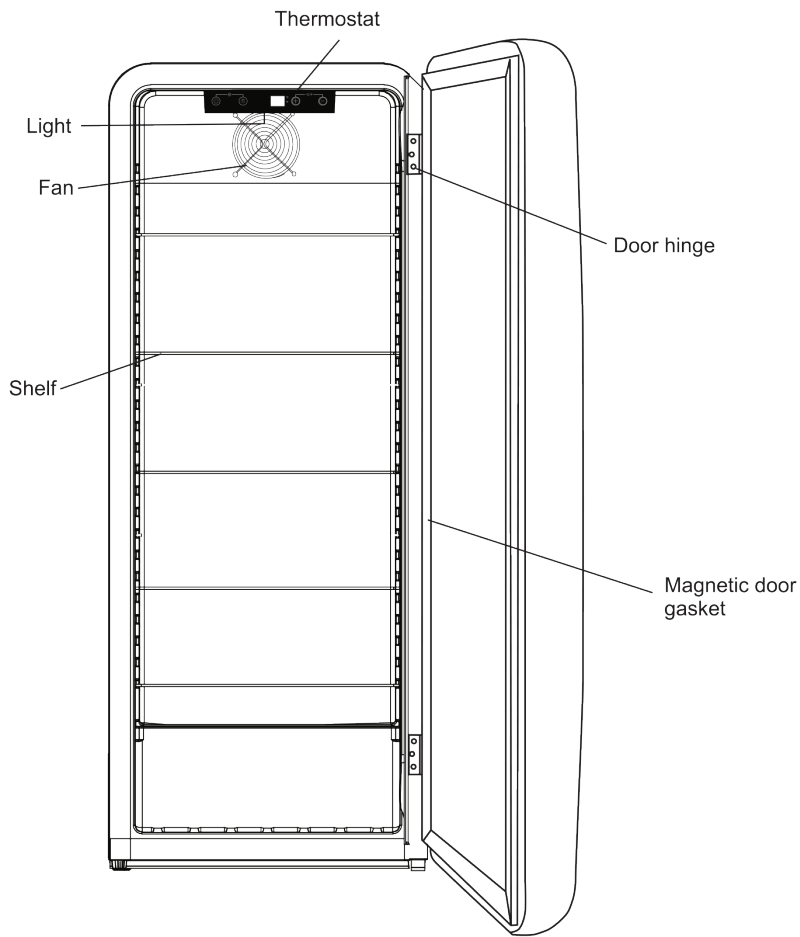

Getting Started

Unpacking

- This product has been packaged to protect it against transportation damage. Remove all packaging materials from around and inside the appliance, **but do not remove any foam insulation surrounding the pipes at the back.** Keep the original packaging carton and materials in a safe place; it will help prevent any damage if the product needs to be transported in the future, and you can use it to store the appliance when it is not in use. In the event that the carton is to be disposed of, please recycle all packaging materials where possible.
- Plastic wrapping can be a suffocation hazard for babies and young children, so ensure all packaging materials are out of their reach and disposed of safely.
- Parts: Check to ensure you have all the parts pictured on the previous page spread.
- Unwind the power cord to its full length and inspect it for damage. Do not use the appliance if the appliance or its cord have been damaged or are not working properly. **In case of damage, contact our after sales support line for advice on examination, repair or return of the damaged product.**
- Make sure the refrigerator is disconnected from the power supply before cleaning the interior surfaces and all internal accessories with lukewarm water, a soft cloth and a neutral/mild soap/detergent. This will remove any dust from transit and storage and help remove the typical smell of a brand new product. Then dry thoroughly. **Important:** do not use harsh or abrasive detergents or powders as these will damage the finish.

Door handle installation

There are several types of handles for different models. Please check which type of handle on your unit.

Type I :

- The door handle comes unattached due to packaging restrictions. It is easily attached following the instructions below.
- Align the screw holes in the handle with the mounting points on the screw base pre-fitted to the fridge door.
- Attach the handle with the supplied screws using a Phillips head screwdriver.
- Ensure the handle is secured firmly into position on the handle base, as illustrated.



#1 Door Plate
Qty. 1



#2 Screw
Qty. 4



#3 Door Handle
Qty. 1



#4 Screw
Qty. 2

ATTACHING DOOR HANDLE

1. Fasten the #1 Door Plate to the refrigerator door by using four #2 Screws.
2. Place the #3 Door Handle onto the #1 Door Plate, then secure with two #4 Screws.



Type II :

The door handle comes unattached due to packaging restrictions. It is easily attached following the instructions below.

- Align the screw holes on the handle base with the holes in the fridge door, then affix the handle base with the supplied four screws using a Phillips head screwdriver.

Slide the handle firmly into position on the handle base, as illustrated, until it clicks securely into place.

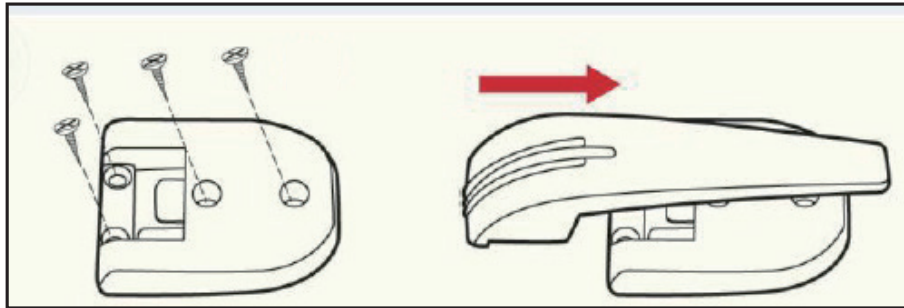

Type III:

The door handle comes unattached due to packaging restrictions. It is easily attached following the instructions below.

- Fix the two screws(1) on the door.
- Put the metal handle(2) into the two fixed screws, match the two holes on the handle.
- Fasten the lower two screws(3) on the handle lower.

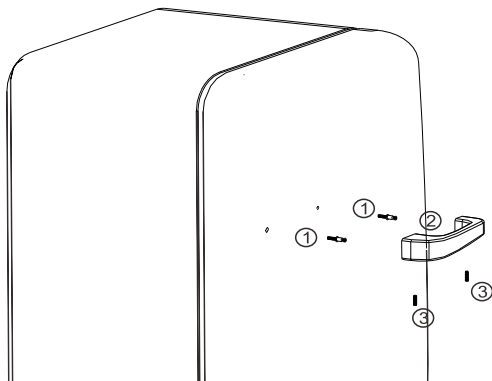

Installing the refrigerator

- Before installing your new fridge, read all safety instructions in this manual, then follow the instructions below:
- Place the fridge on a sturdy, level floor for quieter operation. Ensure that the floor is strong enough to support the fridge when it is fully loaded.
- If the refrigerator is to be placed on carpet, support it with a wooden board underneath. **Be aware that placing the refrigerator on carpet may mean that heat from the compressor may cause the carpet to fade.**
- **This appliance is designed to be freestanding only and should not be recessed or built in.**
- Do not tilt the fridge more than 45° from upright when moving it.
- Avoid areas where the appliance would be exposed to direct sunlight, sources of heat (stove, heater, radiator, etc.), extreme cold ambient temperatures or excessive moisture and high humidity. Installing it in the coolest area of the room will save energy consumption and running costs.

⚠ WARNING!

- **Handle with care!** Do not apply force to any part such as the condenser or door. The metal rails on the bottom underneath of this refrigerator may have sharp edges, so always unpack and handle with care. Do not drag the unit: place it carefully in position to avoid scratching the floor.

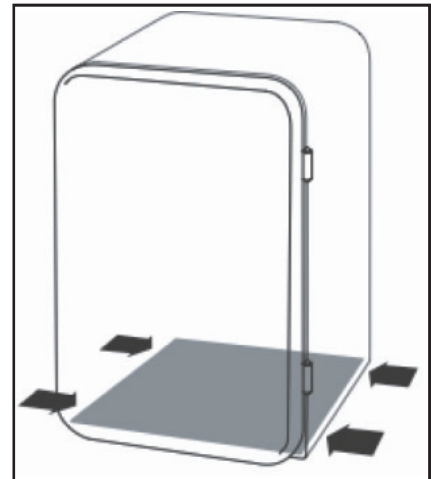

Space requirements

- Place the unit so there is enough space for the door to open.
- Ensure that air can circulate freely around the back of the cabinet, which is necessary to cool the compressor and condenser. Allow at least 100mm clear space at the back and 50mm at the sides of the unit.

Levelling

- The appliance must be installed level in order to work properly. If the unit is not level, the doors and magnetic seal alignments will not be covered properly.
- To level the unit, adjust one or both levelling feet at the base of the unit.

There are several types of controller/thermostat for different models. Please check which type of controller on your unit.

Mechanical Controller

- The mechanical thermostat temperature control and the LIGHT on/off switch is located at below places:

Type I :

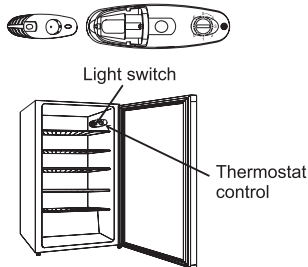

Type II :

Back of unit

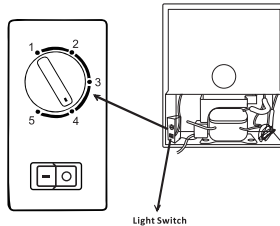

Type III:

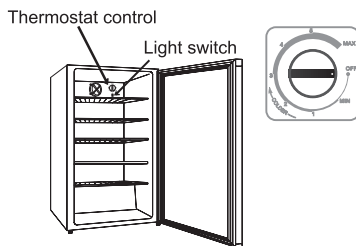

Type IV :

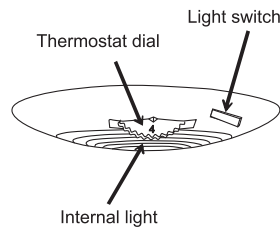

Setting The Temperature Control:

- To start the refrigerator, turn the temperature control to the position corresponding to the desired cooling.
The temperature of the refrigerator is controlled by adjusting/setting the thermostat control knob, located on the top in the cabinet.

For Type II Temperature Setting

- Setting 1(MIN) = lowest setting (warmest internal temperature)
Setting 5(MAX) = highest setting (coldest internal temperature)

For Type III Temperature Setting

- The settings 0(OFF) - 5(MAX) regulate the interior temperature of the refrigerator.
Setting 0(OFF) = not operating (Please press the knob and turn to get the "0" position)
Setting 1(MIN) = lowest setting (warmest internal temperature)
Setting 5(MAX) = highest setting (coldest internal temperature)

For Type I, Type IV Temperature Setting

- The settings 0(OFF) - 7(MAX) regulate the interior temperature of the refrigerator.
Setting 0(OFF) = not operating (Please press the knob and turn to get the "0" position)
Setting 1(MIN) = lowest setting (warmest internal temperature)
Setting 7(MAX) = highest setting (coldest internal temperature)

⚠ NOTE: The refrigerator temperature will vary depending on the quantity of cans/ bottles stored and on the frequency with which the door is opened. The internal temperature varies in different parts of the refrigerator. The back of the refrigerators is coldest. Please keep the cans/bottles away from the rear wall to avoid freezing the bottles and to allow circulation of cold air.

⚠ NOTE: Thermostat 0(OFF) position indicates the refrigerator is turned off although power is still being supplied. By turning the thermostat dial to the left, the refrigerator will turn on automatically. When the refrigerator is not to be used for a long period of time, disconnect the plug and leave the door partially open.

DEFROSTING

The surface of the evaporator ices up when the Refrigerator is working. This is an entirely normal part of operation. If the frost layer is more than 3mm / 1/8" thick, the Refrigerator must be defrosted and cleaned to avoid unnecessary energy consumption and inefficient operation.

- Remove all items inside and unplug the Refrigerator.
- After defrosting, clean the Refrigerator and allow it to dry.
- Reconnect to the mains supply and run the refrigerator.

Electronic Controller

The electronic controller is located on the evaporator fan fix plate inside of the unit.

It looks like this:

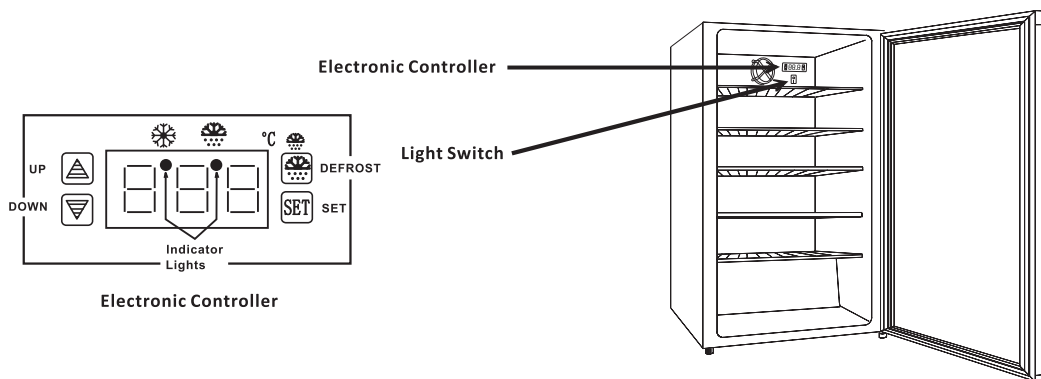

During normal operation the controller display  will show the temperature inside the refrigerator.





A small indicator light  will illuminate under the 'Cooling' symbol to confirm the fridge is in its normal cooling mode, and compressor is running.

When temperature is reached and the compressor is in its 'off' cycle, no indicator

light will illuminate in the controller: 

Operation of the controller:

- To set the desired temperature of the fridge:

- Press the  button once. A 'beep' will sound, and the display will start to flash.
- Use the   buttons to set to the desired temperature.
- Press  again to complete the operation, or just leave it for 5-10 sec, and the display will revert back to showing internal temperature, while new settings saved.



NOTE:

The fridge is built to automatically defrost and prevent any ice forming on the Evaporator.

When in a 'Defrost' cycle, the indicator light

will illuminate under the 'Defrost' symbol: 

- To manually activate 'Defrost' cycle:

- Press the  button, and hold it for 6 seconds, until a 'beep' is heard.
- The indicator light will now illuminate under the 'Defrost' symbol

and the fridge is into a 'Defrost' cycle. 

- 'Defrost' will run for 20mins, and then automatically revert to normal operation.

- To manually change back to normal operating mode from the 'Defrost' mode:

- Press the  button again, hold the button for 6 seconds, until a 'beep' is heard.

- Both indicator lights under the 'Defrost' symbol and under the 'Cooling' symbol

will flash  while the fridge is gearing up to switch back to normal operation.

- After 5-20 minutes, only the indicator light  will illuminate under the

'Cooling' symbol to confirm the fridge is back in its normal cooling mode.

Touch panel temperature setting:

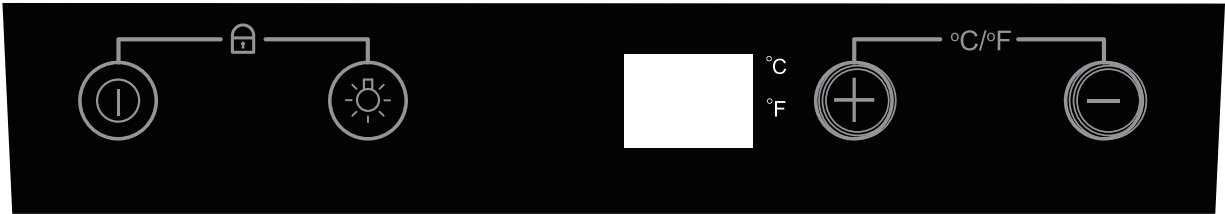

1. Press and hold to turn the Power ON and OFF
2. Press and hold (1) and (3) simultaneously to Unlock and Lock the Control Panel
3. Turns the Interior Light ON and OFF
4. Displays the Temperature
5. Increases Set Temperature 1°C/1°F with Each Push
6. Decreases Set Temperature 1°C/1°F with Each Push
7. Press and hold (5) and (6) simultaneously to Alter the Temperature Display to Fahrenheit or Celsius.

Food storage

- The refrigerator compartment is suitable for short-term storage of fresh food. The temperature inside varies depending on the amount of food stored, the ambient temperature and the frequency of door opening. Adjust the thermostat accordingly.
- In order to maintain good cooling efficiency and save energy, we recommend you do not open the door for too long or too often. Do not overload the fridge, and keep enough space around items for cold air flow. Do not block ventilation openings.
- The walls of the fridge are equipped with a series of runners so that the shelves can be positioned to suit individual storage requirements.
- In order to keep fruit and vegetables fresh in the salad drawer, make sure they are properly packaged and the cover sits firmly on top of the salad drawer (applicable model).
- Two wine bottles can be stored conveniently in the shelf-hanging wine rack. If you do not require this wine rack, or to remove it for cleaning, pull the shelf that holds the rack completely out of the fridge, then slide the wine rack off the side of the shelf (applicable model).

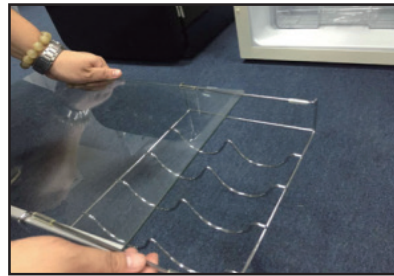
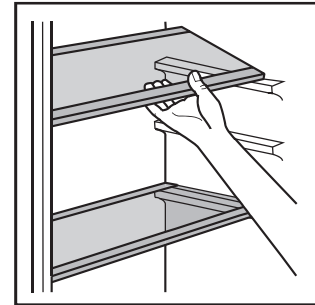

Energy saving tips

- Place the fridge in the coolest area of the room, away from heat-producing appliances and out of direct sunlight.
- Let heated food and beverages cool to room temperature before placing them into the fridge.
- Do not overload the fridge as it forces the compressor to run longer.
- Wrap foods properly and wipe containers dry before placing them in the fridge. This cuts down on frost build-up inside the fridge.
- Do not line any fridge storage bin with aluminum foil, wax paper or paper towels. Liners interfere with cold air circulation, reducing cooling efficiency.
- Position food so that air can circulate freely around it.
- Do not leave the fridge door open for longer than required.
- Make sure no food touches the back of the compartment.
- Don't set the thermostat on exceeding cold temperatures.

Maintenance & Cleaning

Disconnect the appliance from the power supply before cleaning.

Internal Cleaning

- Do not pour water over the appliance.
- The cavity should be cleaned periodically using a solution of bicarbonate of soda and lukewarm water (5ml to 0.5 litre of water)
- Clean the accessories separately with soap and water. Do not put them in the dishwasher.
- Do not use abrasive products, detergents or soaps.
- After washing, rinse with clean water and dry carefully.
- When you have finished cleaning reconnect the plug with **dry hands**.

External Cleaning

- Wash the outer cabinet with warm soapy water. Do NOT use abrasive products.
- There are sharp edges on the underside of the product so care should be taken when cleaning.
- Once or twice a year dust the rear of the appliance and the compressor at the back of the appliance, with a brush or vacuum cleaner, as an accumulation of dust will affect the performance of the appliance and cause increased energy consumption.

WARNING!

- Never clean the unit with an abrasive, acid, oil or solvent based cleaning agent, or with abrasive pads or scourers. Never use flammable fluids or sprays for cleaning as the fumes from these substances can create a fire hazard or explosion.
- Never clean the appliance with a steam cleaner. Moisture could accumulate in the electrical components, danger of electric shock! Hot vapours can lead to the damage of plastic parts.
- The appliance must be completely dry before it is placed back into service.
- Ethereal oils and organic solvents can attack plastic parts, e.g. lemon juice or the juice from orange peel, or cleansers that contain acetic acid. Do not allow such substances to come into contact with the appliance parts.

Going away?

- **Short vacation:** Leave the fridge operating during vacations of less than a month.
- **Long vacation:** If you are not going to use the fridge for longer periods, remove all food and unplug the power cord. Clean and dry the interior thoroughly. To prevent odour and mould growth, leave the door open slightly, blocking it open, if necessary. (Restrict children's access to the room with the open fridge to avoid creating a child entrapment risk.)

Moving the fridge

- Unplug the fridge and remove all food from inside. Securely tape down the drawer and shelves and tape the door shut. Turn the levelling feet up to the base to avoid damage.
- **CAUTION:** Never pick up the refrigerator by the door.
- Protect the outside of the unit with a blanket or similar soft material and make sure the fridge stays secure in the upright position during transportation.

Disposal of Old Appliances

Be sure to make any locks unusable, remove any door(s) and discard separately. Warning - chemical hazard: do not allow children to play with the old appliance. Contact your local authority for disposal procedures.

- Before disposing of an old appliance, please make sure it is switched off and safe. Unplug the appliance and break any locks in order to avoid children becoming trapped.
- Please note: refrigeration system contains gas and refrigerants which require specialised waste disposal. Some vulnerable materials in a refrigerator are not damaged prior to disposal. You can contribute to environment awareness by insisting on an appropriate non-polluting method of disposal.

Disposal of Packaging

Do not allow children to play with the packaging, and dispose of plastic bags safely.

- The cardboard may be broken or cut into smaller pieces and recycled. Any wrapping cover is made of polyethylene. The polyethylene pads and padding contain no fluorochloric hydrocarbons, and as such are most suitable for adequate recycling.

⚠ WARNING!

- **Risk off child entrapment. Before you throw away your old appliance:**
- Take off the doors.
- Leave the shelves in place so that children may not easily climb inside. Cut the connection cable (as close to the appliance as you can).
- If this appliance you are replacing features a spring lock (latch) on the door or lid, be sure to make that spring lock unusable before you discard the old appliance. This will prevent it from becoming a death trap for a child.



Correct Disposal of this product:

This marking indicates that this appliance should not be disposed with other household wastes. To prevent possible harm to the environment or human health from uncontrolled waste disposal, recycle it responsibly to promote the sustainable reuse of material resources.

Troubleshooting

Problem	Solution
The fridge doesn't work	Check that the appliance is switched on.
	Check that there has not been a power cut.
	Check that the plug is not faulty.
	Check that the fuse has not blown.
	Check that the voltage is correct for the appliance.
	Are there any faults with the socket? For this purpose, try the plug of your appliance by connecting it to a socket which you are sure is working.
The temperature inside the appliance is not cold enough	Check that there is not too much food in the appliance.
	Check that the thermostat is set to a suitable temperature.
	Check that the appliance is not placed in direct sunlight, or too near to a heating source.
	Check that the ambient temperature is within the operation limits of the appliance.
	Are the doors of the appliance opened frequently? Once the door is opened, the humidity found in the air in the room enters the appliance, especially if the humidity levels in the room are very high. The more frequently the door is opened in humid conditions the more chance of the build up of moisture.
	The door is not closed completely.
	The door gasket does not seal properly.
The temperature within the appliance is too cold	Increase the working temperature by adjusting the thermostat to a lower setting.
	The highest setting should only be used as a rapid cool setting and should only be set 2 hours before a large amount of food is placed in the fridge. If this is not done the temperature in the fridge compartment could fall below 0°C as the compressor will run continuously.
Moisture forms on the inside or outside walls of the fridge	Hot and humid weather increases the internal rate of frost build-up. This is normal.
	Open the door less often and make sure it is always properly closed.
The outer surfaces of the appliance are wet	Condensation will form on the outside of the cooler if it operates in moist areas, simply wipe it dry.

Troubleshooting

Problem	Solution
Smell/odour	<p>Check all the food and drink that is in the fridge is in date and correctly packaged. If it isn't then it should be removed immediately or repackaged.</p> <p>Check for spillages on each shelf, rack and drawer. You may need to remove the drawers to check that no spillages have settled underneath them. Spillages that have not been cleaned and have been left can cause smells and unwanted odours.</p>
The doors do not close properly	Ensure there are no obstructions preventing door closure.
	Check the door compartments and shelves are correctly in place.
	Check the door seal is not warped or torn.
	Check the appliance is level.
Unusual noises	Check that the appliance is on a flat, level surface and is stable.
	Check the spacing's around the appliance and ensure it is not touching other items.
	Bubbling and gurgling sound: This noise is emitted as the coolant fluid flows through the pipes within the system. This is normal.
	Water flowing sound: This is the normal sound of water flowing into the drain trough during the defrosting process.
	If the appliance is operating noisily (compressor noise): This is normal. This noise indicates that the compressor is operating normally. As the compressor is being energized, it might run a bit more noisily for a short period of time.
Contraction and expansion of the inside walls may cause popping and cracking noises.	
The fridge door will not open.	If the door has just been opened, leave it for a few minutes to allow the air pressure to equalise before trying again.
The compressor runs continuously.	The temperature is set too cold: select a lower(warmer) setting.
	The door is open, or something is obstructing proper door closure.
	The door gaskets are worn, dirty or damaged.
	Large quantities of food have been added to the fridge.
	The room temperature is hotter than usual.
The external fridge surface is warm.	The exterior walls can be warmer than room temperature. This is normal while the compressor works to transfer heat from inside the fridge cabinet.



TERMS & CONDITIONS

Cancellation or Fees Terms:

Shipping/Delivery fees are the responsibility of the Purchaser. Seller is not responsible for the carrier's missed/Non delivery for any reason. Delivery is curbside. Optional upgrades in delivery service is an additional fee. If upgraded delivery service cannot be performed properly, Purchaser agrees to accept delivery curbside and the difference in upgraded cost will not be refunded. If item with free shipping/freight is canceled in transit, a charge of 25% of the price of the unit/s plus freight costs both ways will be charged. All damages must be noted at time of delivery on BOL and Seller to be notified within 48 hours of delivery of such damage. Purchaser acknowledges if cancellation is authorized by Seller, a 35% restocking fee and freight both ways will be charged. No cancellation or refund on made-to-order products. If an order has been placed and production has not started, cancellation fee of 15% of total amount will be charged. Cancelled orders paid by Credit Card will have an additional fee of 3% deducted from the total refund. Once your order has shipped, the shipping address cannot be changed. Refurbished units are sold as is. Purchaser assumes risks to the quality and performance of goods and assumes the costs of all necessary service or repair not covered herein.

Defective Return and Exchanges: Prior diagnosis and troubleshooting by Vinotemp Technical Service Team is required for a defective product exchange to occur, should all other repair remedies fail. All defective return exchanges require a Return Authorization Number (RA) assigned by Vinotemp. Any unauthorized defective return to Vinotemp will be rejected at the time of attempted delivery. Return freight costs for defective product is covered by Vinotemp within the first 90 days from date of sale. For defective Return Authorizations issued after the 90th day from date of sale, the purchaser assumes responsibility for any related freight costs within the product warranty term. Purchaser responsible for any/all boxes, packaging materials, etc., to ensure return product is packaged correctly and fit for transit. Vinotemp is not liable for damages resulting from improper packaging or shipper mishandling. Vinotemp is authorized to reject any authorized defective returned product that arrives damaged.

(Box here for check mark) Accept Terms & Conditions

Vinotemp International Corp. ("Seller") and the person or entity that acquires these goods from Seller ("Purchaser") hereby fully agrees to the following terms and conditions of the sale: Shipping/Delivery fees are the responsibility of the Purchaser whether freight prepaid or freight collect. Seller assumes responsibility for the goods sold to the Purchaser until the goods have reached Purchaser's delivery address (FOB Destination) and the delivery receipt is signed clear. Seller is not responsible for the carrier's late delivery, missed delivery, unpaved roads, remote locations, stairs, elevators, narrow door openings and other such issues in attempting to fit or deliver the goods into the Purchaser's location. Delivery to remote locations may require additional fees. Remote location may be defined at the discretion of the carrier as more or less than 50 miles from the nearest major city. Purchaser assumes all responsibility for additional costs related to freight such as access, measurement, installation, hookup, wiring, moving and storage of the goods,

flight of stairs, carrier's inability to safely and/or adequately deliver, inability to use the building elevator to lift the goods, narrow openings, along with any additional costs to deliver or redeliver the product properly. Make sure to review access to the property and size of the product ordered. The transportation of all goods is subject to the terms and conditions which the carrier imposes on Purchaser. Installation is the responsibility of the Purchaser. If white glove delivery was ordered and cannot be performed properly, or access is hindered in any way, Purchaser agrees to accept delivery curbside (delivery service cannot be refunded). If Purchaser will-calls or pays for their own freight responsibility transfers to the Purchaser when the Purchaser or Purchasers freight company picks up the unit from Seller. Freight quoted are either curbside, threshold or white glove. Standard white glove delivery is main floor, easy access and NO STAIRS, Doors, aligned feet attached (if necessary) and removal of packaging, additional fees for additional requests. Each service has a different rate and will require additional fees. If freight is not charged (Free Shipping or Freight Included) and the order is cancelled after shipping, a freight charge of 25% of the cost of the unit, each direction will be charged. Item swap outs are arranged as curbside delivery and pickup unless noted otherwise. There is no white glove service for returns. Approved returns must have original and/or proper packaging. Swap-outs (Delivery and Pick up are at the same time) Original unit must be packed and ready for carrier pick up at time of delivery of new unit. Packaging of old unit must be adequate for shipping, not oversized or on a pallet if unit was not originally delivered on a pallet. Carrier will not drop off new unit if the original unit is not ready. If the carrier has to make a second attempt, customer will be subject to additional charges for the attempted delivery and for any packaging issues. Deliveries include ONE attempt by the shipping company to deliver the product to the consumer. If for any reason the customer is unavailable to accept the order and the product is undeliverable under any circumstances, the customer will be responsible for any extra shipping and handling charges. We are a manufacturer not a shipping company, deliveries are done by a 3rd party service. Email us at info@vinotemp.com for a quote or any additional information. Freight discussed is Continental USA (excluding Alaska, Puerto Rico, Hawaii), cost is additional please email info@vinotemp.com for a quote.

If you use a service repair company without approval or parts not supplied by Vinotemp and your unit under warranty fails to work, we will repair your item provided you ship your unit prepaid to and from our facility in Henderson. Vinotemp is not responsible for install or removal costs or unauthorized repairs. If the repair or unauthorized part damaged the unit, we will provide customer a cost to repair that damage.

California Proposition 65 Warning: The products sold on this ecommerce website and to the public may contain chemicals and other substances known to the State of California to cause cancer and birth defects and other reproductive harm.

Totes made of vinyl, imitation leather, and/or leather material contain lead and/or other substances that are known to the State of California to cause cancer, birth defects and other reproductive harm.

Microfiber "Plastic microfiber" means a small synthetic particle that is fibrous in shape, less than 5 millimeters in length, and is released into water through the regular washing of textiles made from synthetic material.

Composite wood: May contain formaldehyde.



Galvanized metal and some of its constituents contain lead and/or other substances that are known to the State of California to cause cancer, birth defects and other reproductive harm.

Products made of vinyl contain lead, Diethyl Hexyl Phthalate (DEHP), and/or other substances that are known to the State of California to cause cancer, birth defects and other reproductive harm.

Acrylic may contain Acrylic Acid and/or other substances that are known to the State of California to cause cancer, birth defects, and other reproductive harm.

Appliances may contain tin or lead in either the paint or the controllers, and/or other substances that are known to the State of California to cause cancer, birth defects, and other reproductive harm.

Our barware items may contain plastic, acrylic, enamel, crystal, metal and/or other substances that are known to the State of California to cause cancer, birth defects, and other reproductive harm.

Appliances may contain Tin, Lead or Nickel.

Damage: All damages must be noted at time of delivery. If a bill is signed that there is no damage, buyer accepts delivery as free and clear. Any claim for damages of the goods, when FOB Destination, that incurred during shipment by the carrier are insured and handled directly with the carrier by the Seller if noted on the receipt and notified within 48 hours of delivery. OPEN AND INSPECT YOUR DELIVERY. When FOB Destination, if the item is damaged by the freight company, and Purchaser cancels rather than accepts a replacement, the order can be cancelled by paying for freight costs both ways and a 35% restocking fee for stocked items. No cancellation or refunds on custom/made or made to order products. When shipped 3rd Party (FOB Warehouse), Purchaser assumes all responsibility for delivery, payment of freight and freight claims for damages during shipment. Manufacture defects will be handled directly with Seller, subject to the limited warranty below.

Fees: All sales are final. Unless authorized in writing by the Seller, Purchaser may not return the goods under any circumstance. If Seller agrees in writing to take back stocked goods, there will be a restocking/service fee that is 35% of the purchase price of the goods and freight both ways (product must be new, unused, and in original packaging). If Purchaser returns goods claiming that the goods are defective and goods are found to be in working condition by the Seller, Purchaser is liable for the cost of freight both ways plus and a service fee that is 35% of the purchase price of the goods. Built to Order and Custom products are nonreturnable, nonrefundable. Purchaser must notify Seller of nonconforming goods within 48 hours of receipt, after which time all goods are deemed accepted by the Purchaser. If an order has been placed and production has not started, cancellation of your order will be a 15% charge. If Purchaser tenders payment with a check that has insufficient funds (NSF), a collection fee plus NSF fee of \$50 will be added to the invoice, which Purchaser agrees to pay promptly. If Purchaser puts a stop payment on a check or credit card for any reason, Purchaser agrees to pay for all costs associated with the Seller's collection or litigation of such a claim, including, without limitation, general and special damages, court costs and attorneys' fees. Finance charges begin the date of invoice. Title to the goods reverts back to the Seller in the case of nonpayment of goods or services. All fees and costs to retrieve the product, cost of freight, legal costs, collection fees and court fees, credit card fees and interest rate of 18% (annual rate) will be the responsibility of the Purchaser. In a credit card dispute, Purchaser assumes and must immediately pay any "credit card arbitration" fees and chargeback fees which the credit card companies charge at the time of the chargeback. Cancelled orders using a Credit Card will have an additional fee of 3% deducted from the refund.

Any disputes not resolved within 30 days from the invoice date will be reported to credit reporting agencies.

LIMITED WARRANTY: Seller warrants that the goods will be free of defects in materials and workmanship as follows:

Furniture style (wood) wine cabinets made in the U.S.: all cooling unit parts only for a period of 1 (year) year; cabinetry and labor (uninstalled) for a period of 12 (twelve) Months (Model numbers "Vino" and "Custom").

Metal cabinet units (appliances) (compressor) (made in China and Denmark)(Model numbers start with EL, VT, IL, or EP: parts and labor for cooling system and cabinetry for a period of 12 (twelve) months.

Thermoelectric Units: 90 (ninety) days (including Wine and Beverage Coolers, Beer Dispensers, Humidor, Portofino Wood Cellars, and Refrigerators). (Models start with EL, VT, IL or EP). WineMate and Cellar Tec (WM, Wine Mate or CT)(Wine Cooling Units) Split and Ducted Systems and other installed cooling units are parts only for 1 year, no labor. Self Contained WineMate Cooling Systems are 1 year parts, 1 year labor. Removal and reinstallation of cooling units is not included.

Wine Accessories, Racking Systems, Parts and Other miscellaneous items is a 30 day warranty.

Il Romanzo units: Warranty 90 (ninety) days. Replacement part 12 (twelve) months from the date of sale.

Brama: 1 year warranty from date of purchase.

Non-New Units (Scratch & Dent/Refurbished/Floor Models), warranty for compressor units is 90 days from your dated invoice and 30 days for thermoelectric units (parts for function only, not cosmetic defects). These units are refurbished and sold as is; Purchaser assumes risks to the quality and performance of goods and assumes the costs of all necessary service or repair not covered herein. Extended warranties via New Leaf may not be purchased on Non-New Units. Delivery is curbside. Upgrades in delivery will require an additional fee.

Element Grills (via Element Products LLC), grills have a thirty day limited parts warranty on grill accessories.

If a model is not listed here will have 90 day warranty on parts only if it's a new item.

Parts and Repairs: Warranty on in-house repairs: 90 days parts and labor for compressor; 30 days parts and labor for Thermoelectric; Customer is required to put down a labor deposit of \$75 for Thermoelectric units; \$150 for compressor based Wine Coolers and \$195 for WineMate units which will be kept if a unit is found to be in good working condition. Customer is responsible for freight costs to us.

Warranty on parts purchased: 30 days; if part fails within 30 days of purchase, customer is to ship us back the part; upon inspection, if defective, VT will send replacement part at no charge.

If a purchaser claims a product is "defective" with regards to refrigeration, Purchaser must obtain a letter from a qualified refrigeration technician at the Purchaser's cost to verify that the unit was installed properly, with proper ventilation and the unit is truly malfunctioning due to a manufacturing defect.



Removal or reinstallation of a unit is not included in warranted costs. Purchaser's exclusive remedy is limited at Seller's option to repair or replace defective part[s] with either new or reconditioned part[s]. Purchaser is responsible for shipping the unit prepaid to a designated facility and Seller will pay return shipping charges in the continental United States for items repaired under warranty within 12 (twelve) months from date of sale. The returned unit must be packaged correctly, with enough protection to ensure the unit is not further damaged. Oversized or lack of packaging is not permitted and will be refused. Replacement or exchanged units will be returned to Purchaser through curbside delivery only. Any redelivery fees are the Purchasers responsibility. Since the natural variation in texture, density, grain, color, tone, and shade of wood is unavoidable; Seller does not guarantee the texture, color, tone, or shade of the wood: nor does seller guarantee the colorfastness of wood or against peeling, chipping, cracking, or scratching. Note: Unfinished wood is subject to warping; all wood surfaces must be sealed before placing cellar into service. Make sure doors are aligned by reviewing the owner's manual. Improper repair or placement of the unit will void the warranty. Any third party repair facility must be preapproved in writing by Seller, before providing replacement parts under warranty. Change Orders: Custom units already in production that require a change will be subject to a change order fee.

Storage Fees: When having an item serviced by a Vinotemp service technician at the Vinotemp facility, Purchaser agrees to pick up their repaired item or make arrangements for return shipping within a 30 day period once they have been notified by Vinotemp through phone call, email, or letter that their unit is ready for pick up. If the item remains in the Vinotemp warehouse after 30 days but no longer than 60 days, the Purchaser will incur additional storage fees of 2%. After 60 days in storage, the item will become property of Vinotemp. For custom units with deposits: If product is not picked up or shipped within 60 days of completion, Purchaser deposit is forfeited and product becomes the property of Vinotemp. Warranty period is from the date of sale (not from shipping, delivery, nor installation). All completed cabinetry, racking, or other custom work must be picked up or shipped within a period of 14 days after Vinotemp has notified the Purchaser by phone call, email, or letter. Any completed cabinetry, racking, or other custom work stored longer than 14 days will incur an additional monthly storage fee. After 60 days, the product will become property of Vinotemp.

This Limited Warranty does not cover damage due to such things as accident, misuse, abuse, mishandling, neglect, acts of God, fires, earthquakes, floods, high winds, government, war, riot or labor trouble, strikes, lockouts, delay of carrier, unauthorized repair, or any other cause beyond the control of the Seller, whether similar or dissimilar to the foregoing. Seller is not responsible for any damages caused to Purchaser's property resulting from the goods. This limited warranty applies only inside the Continental US (Alaska, Puerto Rico, Hawaii and other territories/countries are not warranted). Purchaser understands and acknowledges that the goods sold here are wine cellars, cigar humidors, and/or other similar units which house wine or cigars or other items. Purchaser assumes all risk of using these units, including risk of spoilage, humidity variations, temperature variations, leaks, fire, water damage, mold, mildew, dryness and similar and any other perils that might occur. Seller is not responsible for incidental or consequential damages, and there are no warranties, expressed or implied, which extend beyond the Limited Warranty described above. Warranty and liability are nontransferable. The implied warranties of merchantability and of fitness for a particular purpose are hereby expressly disclaimed. Some states do not allow the exclusion of incidental or consequential damages, or a waiver of the implied warranties of fitness and/or

merchantability, so the above limitations may not apply to you. This warranty gives you specific legal rights and you may also have other rights which vary from state to state. Seller disclaims any indemnification for claims of infringement of any intellectual property of protectable nature. In the event of any dispute between Seller and Purchaser arising out of or relating to these terms and conditions or to the goods sold generally, Purchaser must first file a written claim with Seller within ten days of the occurrence giving rise to the claim and wait an additional thirty days for a response before initiating any legal action. The sale and all terms are subject to Nevada law. Any legal proceeding arising out of or relating to these terms and conditions or to the goods sold Purchaser shall bring, solely and exclusively in Clark County. In no event may Purchaser initiate any legal proceeding more than six months after the occurrence of the event giving rise to the dispute. Seller may make nonpayment claims until debt is paid in full. Any dispute or claim relating in any way to these to the Terms and Conditions, the Website, or any products or services sold or distributed by or through this Website, store, or catalog will be resolved by binding arbitration, rather than in court, except that you may assert claims in small claims court if your claims qualify. The Federal Arbitration Act and federal arbitration law apply to the Terms and Conditions. We each agree that any dispute resolution proceedings will be conducted only on an individual basis and not in a class, consolidated or representative action. If for any reason a claim proceeds in court rather than in arbitration we each waive any right to a jury trial. Both parties agree to bring suit in court to enjoin infringement or other misuse of intellectual property rights.

The above terms and conditions are the only ones governing this transaction and Seller makes no oral representations of any kind. These Terms and Conditions can only be modified in writing, signed by both Purchaser and Seller.

SPECIFIC WARRANTY BELOW for SCRATCH & DENT/OPEN BOX/ REFURBISHED/FLOOR MODELS/ CLOSEOUTS, OVERSTOCK: TERMS AND CONDITIONS OF SALE

Vinotemp (and its brands Element, Wine Mate, Cellar Tec, Apex Wine Racks, Epicureanist II Romanzo, Brama("Seller") and the person of the entity that acquires these goods from Seller ("Purchaser") hereby fully agree to the following terms and conditions of the sale:

1. Freight: Vinotemp is not a freight, moving or installation company, if Freight is arranged for the Buyer, the Seller assumes no responsibility for the goods sold to the Purchaser once the goods have left the Seller's premises, including, but not limited to, late delivery by the moving carrier, or for events caused by any difficulty carrier incurs in attempting to fit the goods into the Purchaser's place of business or residence due to the size of the goods or otherwise, such as the disassembly and reassembly of the goods. Purchaser assumes all responsibility for delivery, payment of freight, extra fees, access, measurement, installation, hook-up, moving and storage of the goods. The transportation of all goods is subject to the terms and conditions which the moving carrier imposes on Purchaser including, but not limited to, additional charges imposed per flight of stairs, and/or additional charges resulting from the carrier's inability to safely and/or adequately use the building elevator to lift the goods to an upper floor. Any claim for damages incurred during shipment by the carrier of the goods are insured and handled directly with the carrier and must be noted at time of delivery.



2. All sales are final, and unless authorized in writing by the Seller, Purchaser is not entitled to return goods, under any circumstances. If Purchaser refuses to accept goods, the Purchaser is liable for the return and cost of freight both directions and a restocking/service fee that is 35% of the purchase price of the goods. Purchaser must notify Seller of non-conforming goods within four days of delivery, after which time all goods are deemed accepted.

3. If Purchaser tenders payment with a check that has insufficient funds (NSF), or stops payment on a check or credit card for any reason, Purchaser agrees to pay for all costs associated with the Seller's connection or litigation of such a claim, including without limitation extra damages, court costs, collection fees and attorney's fees. Finance charges begin the date of invoice. Collection fees plus NSF fee of \$50 will be added to your invoice, which you agree to promptly pay. Title to the goods does not pass until payment is received in full by Seller and Seller retains a security interest in the goods until they are paid for in full. If the credit card dispute goes to arbitration, Buyer agrees to pay for credit card arbitration fees.

4. LIMITED WARRANTY on Non-New Units (Scratch & Dent/Refurbished and Floor Models): warranty for compressor units is 90 days from your dated invoice and 30 days for thermoelectric units (parts for function only, not cosmetic defects). These units are refurbished and sold as is; Purchaser assumes risks to the quality and performance of goods and assumes the costs of all necessary service or repair not covered herein. Wine Accessories, Racking Systems and other items not mentioned are not warranted. There is no warranty on parts purchased separately. Removal and re-installation of unit is not included in warranted labor. Purchaser's exclusive remedy is limited, at Seller's option; to repair or replace defective part[s] with either new or factory reconditioned part[s]. Purchaser is responsible for shipping the unit pre-paid to designated facility and Seller will pay return shipping charges in the continental United States for items repaired under warranty. Since the natural variation in texture, density, grain, color, tone and shade of wood is unavoidable; Seller does not guarantee the texture, color, tone or shade of the wood: nor does seller guarantee the colorfastness of wood or against peeling, chipping, cracking or scratching. Note: Unfinished wood is subject to warping; all wood surfaces must be sealed before placing cellar into service. Improper placement of the unit will void the warranty. By Vinotemp in writing, any 3rd party repair facility must be pre-approved before providing parts free of charge.

5. Freight: If As-Is unit is shipped including freight and delivery is denied, customer is responsible for freight to and from buyer. Other costs Buyer is responsible for is storage, repackaging, and attempted delivery fees.

6. Vinotemp does not cover damage due to such things as accident, misuse, abuse, mishandling, neglect, acts of God, fires, earthquakes, floods, high winds, government, war, riot or labor trouble, strikes, lockouts, delay of carrier, unauthorized repair, or any other cause beyond the control of the Seller, whether similar or dissimilar to the foregoing. Seller is not responsible for any damages caused to Purchaser's property resulting from the good. This limited warranty applies only inside the Continental US. (Alaska, Puerto Rico and Hawaii are not warranted.)

7. Purchaser understands and acknowledges that the goods sold here are wine coolers, appliances, cigar humidors, and/or other similar units which may house wine or cigars or other consumables.

Purchaser assumes all risk of using these units, including risk of spoilage, humidity variations, temperature variations, leaks, fire, water damage, mold, mildew, dryness and similar perils that might occur.

8. UNLESS OTHERWISE PROVIDED BY APPLICABLE LAW, SELLER IS NOT RESPONSIBLE FOR INCIDENTAL OR CONSEQUENTIAL DAMAGES, AND THERE ARE NO WARRANTIES, EXPRESS OR IMPLIED, WHICH EXTEND BEYOND THE DESCRIPTION ON THE FACE HEREOF; WARRANTY AND LIABILITY ARE NON-TRANSFERABLE. THE IMPLIED WARRANTIES OF MERCHANTABILITY AND OF FITNESS FOR A PARTICULAR PURPOSE ARE HEREBY EXPRESSLY DISCLAIMED. SELLER DISCLAIMS ANY INDEMNIFICATION FOR CLAIMS OF INFRINGEMENT OF ANY INTELLECTUAL PROPERTY OF PROTECTABLE NATURE.

9. In the event of any dispute between Seller and Purchaser arising out of or relating to these terms and conditions or to the goods sold generally, Purchaser must first file a written claim with Seller within thirty days of the occurrence giving rise to the claim and wait an additional thirty days for a response before initiating any legal action. Any legal proceeding arising out of or relating to these terms and conditions or to the goods sold generally shall be brought solely in Clark County. The prevailing party in any such proceeding is entitled to its attorney's fees and costs. In no event may Purchaser initiate any legal proceeding more than six months after the occurrence of the event giving rise to the dispute.

10. Delivery is curbside. Upgrades in delivery will require an additional fee.

The above terms and conditions are the only ones governing this transaction and Seller makes no oral representations of any kind. These Terms and Conditions can only be modified in writing, signed by both Purchaser and Seller. 03/18/2021





SERVICE & IMPORTANT NOTICE

Upon receipt and inspection of unit, the supply cord must be replaced if it is damaged. Contact our customer service at 1-800-777-8466 or info@vinotemp.com.

The manufacturer has a policy of continuous improvement on its products and reserves the right to change materials and specifications without notice.

WARNING:

**Please do not place the unit within reach of children.
For adult use only**

Contact info@vinotemp.com with any questions or visit

www.vinotemp.com



Add a New Leaf extended warranty to your order, and have the security of knowing that if there should be a problem, even years in the future, New Leaf will be there to assist! Usable for any Wine Cellar or other electronic device manufactured by Vinotemp. Add this warranty to purchases made from vinotemp.com or other qualified vendors. Warranty must be registered within the first 10 days from original purchase.

Visit www.Vinotemp.com to purchase.



732 S. Racetrack Road
Henderson, NV 89015
www.vinotemp.com

Brama is a registered trademark of Vinotemp International. All products, features, and services are subject to change without notice. We cannot guarantee the accuracy of the contents of this document. We disclaim liability for errors, omissions, or future changes.

© 2021 Vinotemp International. All rights reserved.