

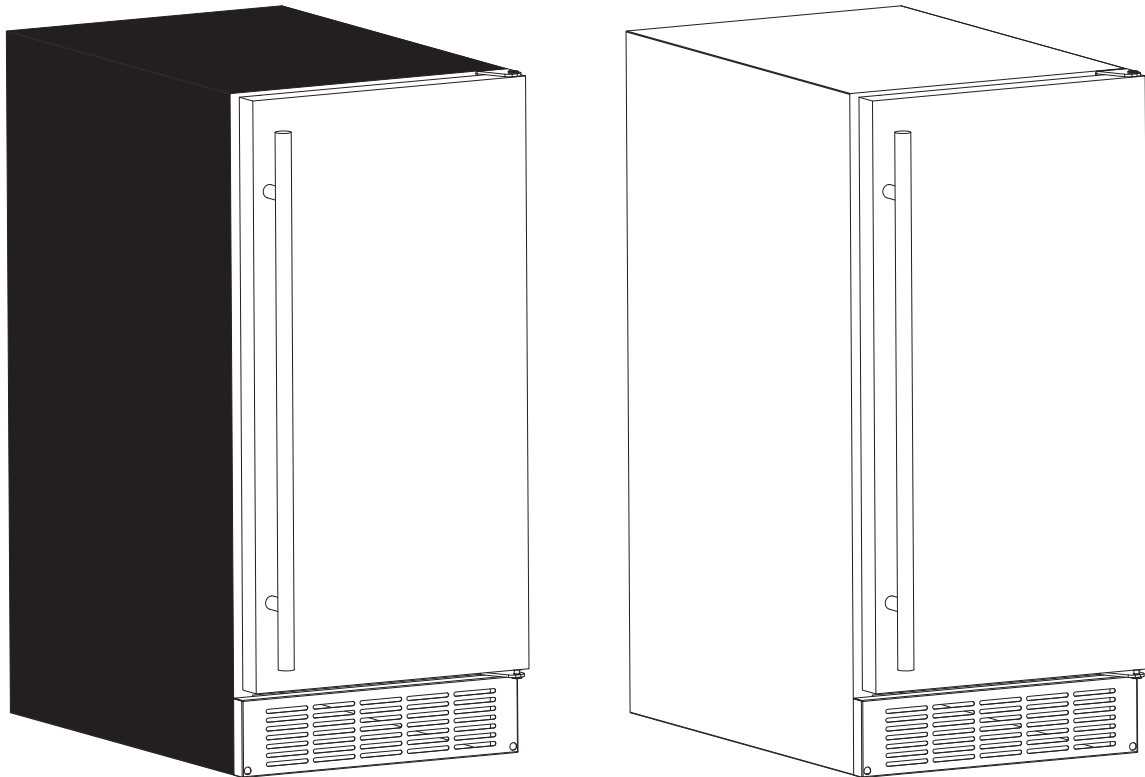

A PROUD HERITAGE OF EXPERIENCE & QUALITY



# AUTOMATIC ICE MAKER

BR-15INIM-B BR-15OUIM-SS

OWNER'S MANUAL



WWW.VINOTEMP.COM



**A Proud Heritage of Experience & Quality**

# **PRODUCT REGISTRATION**

## **Purchase Confirmation**

With the information you provide, we can confirm the date of purchase for your product. The confirmation is of benefit to you, especially if your original proof of purchase is lost.

## **Product Registration**

Completing this product registration is the only way to guarantee you will be notified of substantive issues that arise concerning your product.

## **Become a Member of the Vinotemp® Family**

Complete this product registration with your e-mail address and receive special offers and updates on new products via e-mail.

## **IMPORTANT:**

**Complete your product registration today!**

**Visit product and warranty registration at:**

**<https://www.vinotemp.com/extended-warranty/register-warranty>**

For more information on warranty service and repair, please refer to the appropriate section of your product literature.

For additional information about Vinotemp products, visit [www.vinotemp.com](http://www.vinotemp.com) or call toll-free 1-800-777-8466

**Please also fill out the Questionnaire below for a chance to receive a FREE GIFT.**

**<https://www.vinotemp.com/product-registration-form>**

For more information on Prop 65, go to:

**<https://www.vinotemp.com/prop65>**



# GENERAL OPERATING INSTRUCTIONS

Remove all external and internal packaging from your appliance. Be sure that all parts have been included before discarding any packaging materials. You may want to keep the box and packing materials for use at a later date.

Upon receipt and inspection of unit, the supply cord must be replaced if it is damaged. Contact our customer service at 1-800-777-8466 or [info@vinotemp.com](mailto:info@vinotemp.com).

**Let the unit rest UNPLUGGED for 24 hours once you have it placed in your home.**

**READ ALL INSTRUCTIONS BEFORE USING THIS APPLIANCE**

**-Save these instructions-**

**To register your product, visit:**

**<http://www.vinotemp.com>**

**Register your warranty within 10 days of receiving the unit.**

**Please be sure to retain your proof of purchase.**

**Protect Your Investment with an Extended Warranty!**



Add a New Leaf extended warranty to your order, and have the security of knowing that if there should be a problem, even years in the future, New Leaf will be there to assist! Usable for any Wine Cellar or other electronic device manufactured by Vinotemp. Add this warranty to purchases made from [vinotemp.com](http://vinotemp.com) or other qualified vendors. Warranty must be registered within the first 10 days from original purchase.

Visit [www.vinotemp.com](http://www.vinotemp.com) to purchase.

# TABLE OF CONTENTS

IMPORTANT SAFETY INSTRUCTIONS .....	5
PARTS AND SPECIFICATIONS .....	6
TECHNICAL DATA .....	7
ELECTRICAL CONNECTION .....	7
CORD INSTRUCTIONS .....	7
INSTALLATION INSTRUCTIONS.....	8
OPERATING YOUR ICE MAKER .....	11
CARE AND MAINTENANCE .....	15
PROBLEMS WITH YOUR ICE MAKER.....	17
TROUBLESHOOTING GUIDE .....	17
TERMS AND CONDITIONS .....	18
SERVICE & IMPORTANT NOTICE .....	26



# IMPORTANT SAFETY INSTRUCTIONS



To reduce the risk of fire, electrical shock or injury when using your appliance, follow these basic precautions:

- Do not operate this or any other appliance with a damaged cord.
- Always unplug the appliance or disconnect power and shut off the water line before cleaning or performing maintenance. Do not run cord over carpeting or other heat insulators and do not cover cord. Keep cord away from high traffic areas.
- Exercise caution and use reasonable supervision when appliance is used near children. Never allow children to operate, play with or crawl inside the appliance. Keep packing materials away from children.
- Do not clean appliance with flammable fluids. Do not store or use gasoline or other flammable vapors and liquids in the vicinity of this or any other appliance. The fumes can create a fire hazard or explosion.
- Do not operate with housing panels removed.
- Do not touch the evaporator with your hand while the appliance is operating.
- Do not touch the condenser fins, they are sharp and can be easily damaged.
- Exercise caution when moving and installing ice maker. The unit is heavy and may require two or more people when moving the unit to prevent strain or injury.
- When disposing of refrigerated appliances, special handling is often required. It is the consumer's responsibility to comply with federal and local regulations when disposing of this product.
- Do not attempt to repair or replace any part of your appliance unless it is specifically recommended in this manual. All other servicing should be referred to a qualified technician.
- Locate the unit away from direct sunlight and sources of heat (stove, heater, radiator, etc).
- To protect against electric shock, do not immerse appliance, plug or cord in water or other liquids. Avoid locating the unit in moist areas.
- Do not use this appliance for other than its intended purpose.
- Place the appliance on a solid, level surface. It is important that the ice maker be level for optimal performance.
- Ensure that all hoses are in good condition without any damage and check for leaks once the water line is connected.
- Turn on the water supply tap before switching on the ice maker. Never turn the water supply tap off when the ice maker is working.
- To avoid injury or death from electrical shock, do not operate the unit with wet hands, while standing on a wet surface or while standing in water.
- Never install or operate the unit in an enclosed area, such as a closed cabinet. To ensure proper ventilation for your ice maker, the front of the unit must be completely unobstructed. Choose a well-ventilated area with temperatures above 45°F and below 110°F.
- The ice maker must be installed with all plumbing, electrical and water connections in accordance with state and local codes.
- Do not use sharp instruments, rubbing alcohol, flammable fluids, or abrasive cleaners to remove tape or glue. These products can damage the surface of your ice maker.
- **WARNING:** Risk of child entrapment and suffocation. Before you throw away this or an old unit, remove the door. Leave the shelves in place, so that children may not easily climb inside.

# PARTS AND SPECIFICATIONS

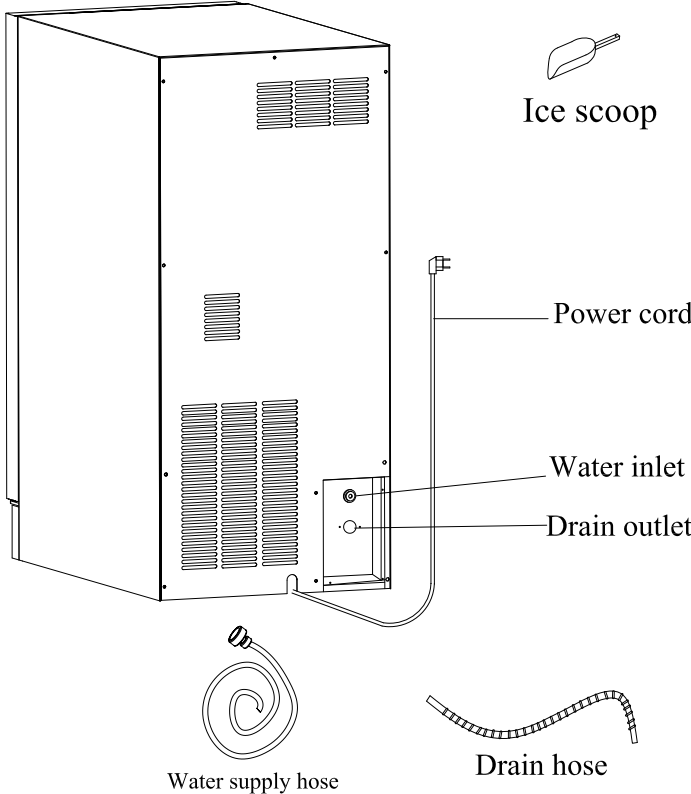
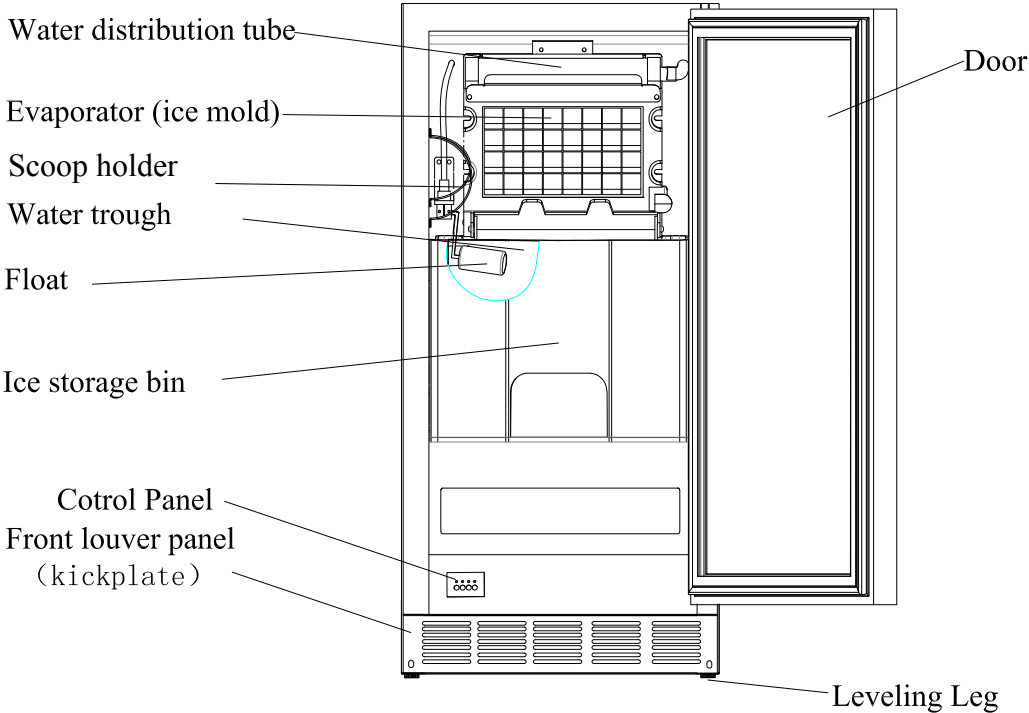

# TECHNICAL DATA

Model No.	BR-15INIM-B	BR-15OUIM-SS
Voltage	AC 115V	AC 115V
Frequency	60 Hz	60 Hz
Rated Current (Ice Making/Harvest)	3.0A/4.0A	3.0A/4.0A
Power Consumption (kWh/100lbs ice)	9.71	9.71
Refrigerant	R134a, 3.88oz	R134a, 3.88oz
Ambient Temperature Range	45° - 110° F	45° - 110° F
Operating Water Temperature Range	41° - 90° F	41° - 90° F
Maximum Ice Storage	25 lbs	25 lbs
Ice Making Capacity (24 hours)	Approx. 50 lbs	Approx. 50 lbs
Ice Cube Dimensions	7/8" x 7/8" x 7/8"	7/8" x 7/8" x 7/8"
Approx. Net Weight	82 lbs	84 lbs
Approx. Dimensions with feet (W x D x H)	14.625" x 24.875" x 32.677"	14.625" x 24.875" x 32.677"
Boxed Dimensions (W x D x H)	16.14" x 26.1" x 34.65"	16.14" x 26.1" x 34.65"

## ELECTRICAL CONNECTION

- Do not under any circumstances cut or remove the third ground prong from the power cord supplied. For personal safety, this appliance must be properly grounded.
- The cord should be secured behind the unit and not left exposed or dangling to prevent accidental injury.
- Never unplug the unit by pulling the power cord. To disconnect the appliance, always grip the plug firmly and pull straight out from the wall outlet. When moving the unit, be careful not to damage the power cord.
- The ice maker should always be plugged into its own individual electrical outlet with a voltage rating that matches the rating label on the unit.
- A standard electrical supply (115V AC only, 60Hz, 15A), properly grounded in accordance with the National Electrical Code and local codes and ordinances, is required.

**IMPORTANT:** Improper use of the grounded plug can result in the risk of electrical shock. If the power cord is damaged, frayed or shows cracks or abrasions across its length, have it replaced at an authorized service center.

## CORD INSTRUCTIONS

For your protection, this unit should be properly grounded. Unit is equipped with a 3-conductor cord set that has a molded 3-prong grounding-type plug, and should be used in combination with a properly connected grounding-type outlet as shown in figure A.

It is not recommended to use this unit with an extension cord or power board. Please ensure that the appliance is plugged directly into the electrical outlet.

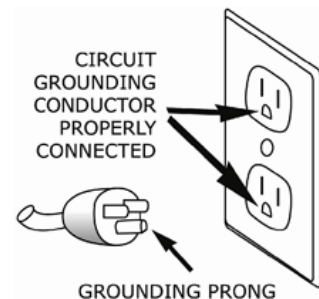

# INSTALLATION INSTRUCTIONS

## Before Using Your Ice Maker

- Remove all exterior and interior packing material.
- Check to be sure that the appliance is in good condition and that the following parts are included:
  - 1 Ice scoop
  - 1 Ice storage bin
  - 5 ft. Drain hose
  - 9 ft. Water supply hose with female adapter & 1 Locking Clip
  - 1 Instruction manual
- Before connecting the ice maker to the power source, let the unit stand upright for 24 hours. This will reduce the possibility of malfunction in the cooling system from transportation.
- Clean the interior surface and ice bucket with lukewarm water using a soft cloth.

**IMPORTANT:** This ice maker should be installed by qualified personnel.

## Positioning Your Ice Maker

- Position the unit in a dry and well-ventilated place. Avoid placing the ice maker near any source of heat or moisture, or in direct sunlight. The recommended ambient temperature should be between 45° and 110°F.
- To allow for proper circulation, the ice maker requires at least a 4" clearance at the back, 1" clearance at the sides and 1" clearance at the top. The front should be unobstructed. The installation should allow the unit to be pulled forward for servicing if necessary.
- Place unit on a flat surface that is strong enough to support the unit when fully loaded.
- The ice maker is designed to be freestanding, recessed (under a cabinet) or built-in.

## Leveling the Ice Maker

- The ice maker must be level to ensure optimal flow through the evaporator. A unit that is not level may result in reduced ice production and noise. A carpenter's level is recommended to ensure level placement.
- The unit can be raised or lowered by adjusting the leveling legs at the bottom of the ice maker.
  - To lower a side of the ice maker, turn the leveling legs to the right.
  - To raise a side of the ice maker, turn the leveling legs to the left.

**IMPORTANT:** When installing in a cabinet or on the floor, you must adjust the feet to level the ice maker and lock the rollers. If the floor is level, adjust the two front feet to touch the floor.





## ***Location requirements***

### ***INSTALLATION CLEARANCES:***

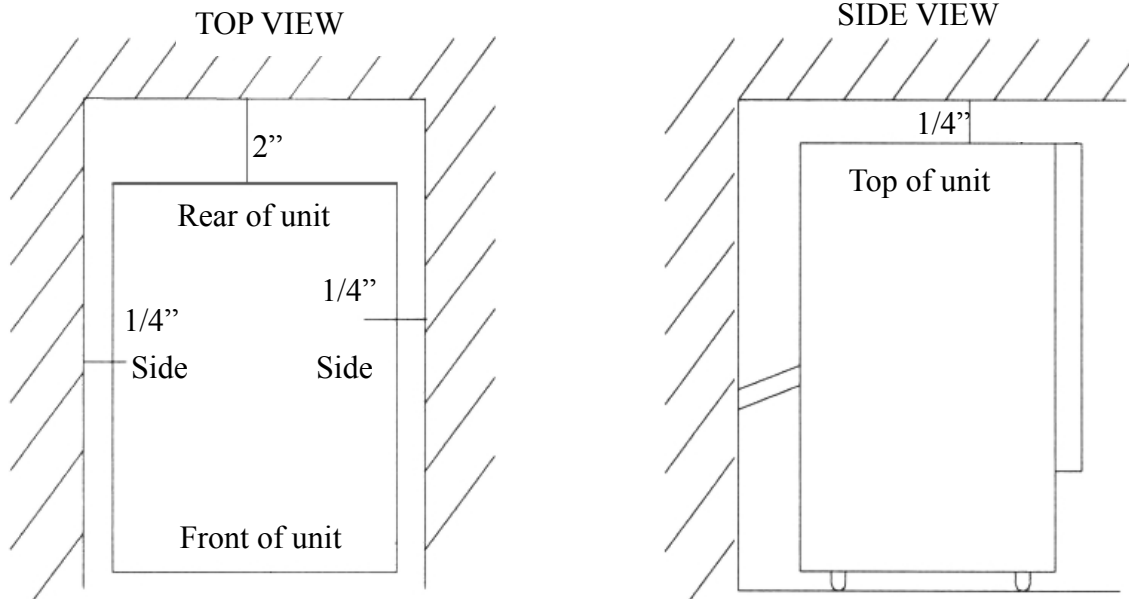

- This ice maker should be properly installed by qualified personnel.
- To ensure proper ventilation for your ice maker, the front of the unit must be completely unobstructed.
- When installing the ice maker under a counter, follow the recommended spacing dimensions shown. Allow at least 2" (50.8 mm) of clearance at rear, and 1/4" (6.35 mm) at sides for proper air circulation. The installation should allow the ice maker to be pulled forward for servicing if necessary.
- Choose a well ventilated area with temperatures above 50°F (10°C) and below 100°F (38°C). This unit **MUST** be installed in an area protected from the elements, such as wind, rain, water spray or drips.
- The unit should not be located next to ovens, grills or other high heat sources.
- The ice maker requires a continuous water supply with a minimum pressure of 15 psig and a static pressure not to exceed 80 psig. The temperature of the water feeding into the ice maker should be between 41°F (5°C) and 90°F (32°C) for proper operation.

## Connecting the water supply

**IMPORTANT:** Improper water line connection may result in flooding. Professional installation is recommended. Review state and local plumbing codes before installation.

- The ice maker requires a continuous water supply with a minimum pressure of 15 psig and a static pressure not to exceed 80 psig.
- The temperature of the water feeding into the ice maker should be between 41°F and 90°F for proper operation.
- Deionized water is not recommended for use with this unit.
- Ensure that hoses are not damaged during installation and check for leaks after connecting the water line.

## Connecting the water line

Step 1 , Press the O-ring collect and Pull out the plug;

Step 2 , Insert the 1/4" tube to the quick fitting;

Step 3 , Insert the locking clip to the quick fitting;

Step 4 , Connect the female adapter to faucet, open up and CHECK FOR LEAKS.

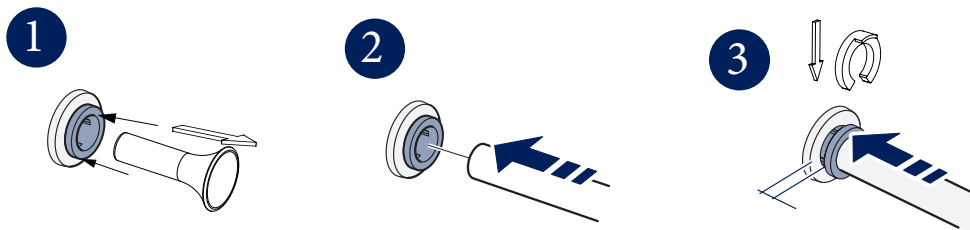

## Connecting the drain line

The drain line must be connected before using the ice maker. If there is a drain line near the ice maker or if the unit is to be used outside, it is best to drain water to the drain line through the drain hose provided with the ice maker.

1. Locate the floor drain near the ice maker. The length of the drain hose provided is 5 feet. Remove the rear drainage plug from the drain outlet at the rear of the ice maker. Connect the nut of the drain outlet to the water draining hose, and insert the other side of the hose into the drain line. Never allow the drain hose to hang or loop higher than the bottom of the ice storage bin.
2. All horizontal runs of drain lines must have a fall of ¼ inch per foot. An air gap will likely be required between the ice maker drain tube and the drain/waste receptacle. A standpipe with a trap below it or a floor drain is acceptable for the drain/waste receptacle.
3. Pour 1 gallon of water into the ice storage bin to check for leaks in the drainage system. Tighten any connections that leak.

**IMPORTANT:** This ice maker is not a freezer. Infrequent drainage will cause a high rate of melting in the ice storage bin.

# OPERATING YOUR ICE MAKER

**IMPORTANT:** Although the unit has been tested and cleaned at the factory, due to long-term transit and storage, the first batch of cubes must be discarded.

## CONTROL PANEL

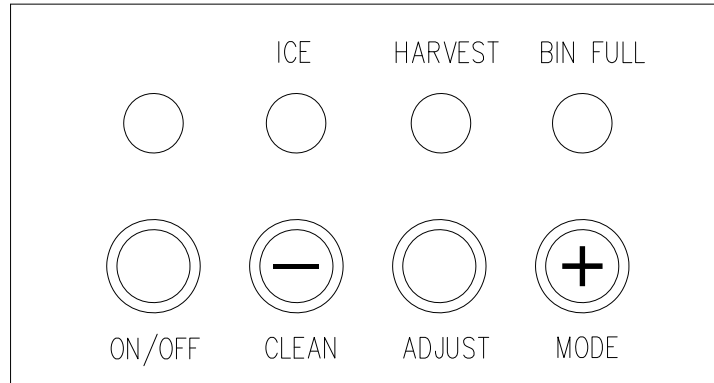

### Control Panel Buttons and LEDS

1. **Bin Full (Red) LED:** Bin full indicator light

When this is lit, the ice storage bin is full of ice or there is something blocking the bin-full probe. The unit will stop working. When ice cubes are removed from the ice storage bin, freeing the bin-full probe, the red LED will remain flashing for 3 minutes, then the unit will restart and return to the ice making mode.

2. **Ice Making(Green) LED:** Ice making indicator light

When this is lit, the unit is working in the ice making mode controlled by a temperature probe on the evaporator. When the green LED flashes, the unit is working in the ice making mode controlled by a fixed timer.

3. **Ice Harvest (Yellow) LED:** Ice harvest indicator light

When this is lit, the unit is working in the ice harvest mode controlled by the ice-full probe.

4. **Mode button:** Mainly for service. When this is pressed, the ice making mode changes to the ice harvest mode or vice versa. The mode can be judged from the status of the green and yellow LEDs.

5. **Adjust button:** Mainly for service. When it is pressed over 3 seconds, the unit will enter the Ice Size Adjustment mode. The mode can be judged from the status of the yellow LED.

### Ice Size Adjustment

1. Press and hold the “Adjust” button for at least 3 seconds. The unit will enter the Ice Size Adjustment mode. The “HARVEST” LED (yellow) will be blinking continuously during the ice size adjustment. Release the button when the LED blinks continuously to adjust the ice size.

2. While in the Ice Size Adjustment mode, press the “Clean” (-) button or the “Mode” (+) button for the desired ice size.

## ***Reversing the door swing***

**Tools needed:** flathead screwdriver, Phillips screwdriver

**IMPORTANT:** *Before you begin, unplug the ice maker or disconnect power.*

**To remove door from hinges:**

1. Using a flathead screwdriver, separate the axis from Hinge 1. Set aside.
2. Open the door about 20° around the axis of Bottom Hinge 2, then lift the door off Bottom Hinge 2 and set door aside.

**To replace door on hinges:**

1. Using a flathead screwdriver, remove the plug buttons from the screw holes opposite the door hinges, top and bottom. Set aside.
2. Replace the axis on the Hinge 1 and tighten it firmly. Remove Hinge 1 and place it on the opposite bottom side.
3. Remove Hinge 2 and place it on the opposite top side. Separate the axis from Hinge 2 and set it aside.
4. Align the door on Bottom Hinge 1 and replace axis on Hinge 2. Tighten it firmly.

Place the handle on the side of the door away from the hinge side.

5. Push the plug buttons into the original screw holes. See Figure below.

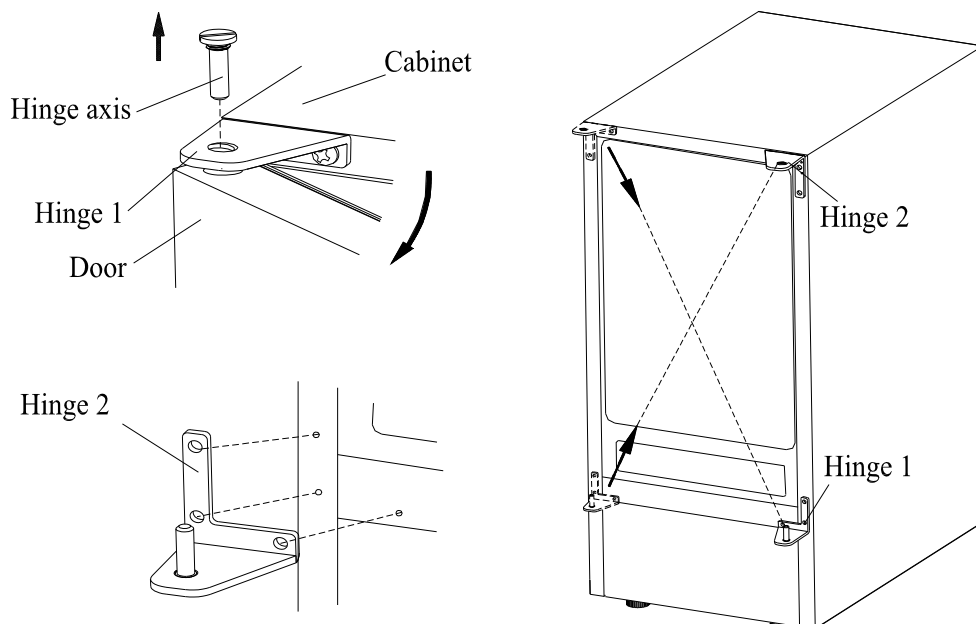

- **Smaller ice setting:** By pressing the “Clean” (-) button, you can decrease the size of the ice cubes. The “ICE” LED (green) will flash as you lower the ice size and will finally be blinking at the setting of smallest ice size.
- **Larger ice setting:** By pressing the “Mode” (+) button, you can increase the size of the ice cubes. The “BIN FULL” LED (red) will flash as the larger size is set and will blink when the setting of largest ice size has been reached.

*After 10 seconds without any operation, the unit will return to the previous mode.*

- **NOTE:** If during the ice size adjustment mode the “BIN FULL”, “ICE” and “HARVEST” LEDs blink all at once, this indicates that the unit is in the regular (middle) setting of the ice size.

When the machine is in the cleaning stage or ice full stage, the ice size adjustment mode cannot be accessed

## Making Ice

Once the ice maker has been properly installed, it is ready for operation.

- Turn on the water tap, let the water trough fill, then set the ON/OFF button to the ON position on the front panel. The ice maker will start working automatically.
- After 3 minutes, the machine will automatically switch to the freeze cycle, and the sound of water flowing will be heard.
- When the batch of ice has been fully formed, ice will automatically be harvested to the ice storage bin.
- When the ice storage bin is full, the sheet of cubes will not fall completely and will hold the ice-full probe open. The machine stops making ice automatically.
- The unit will start making ice again after the ice cubes are removed and the ice-full probe swings back to operating position.

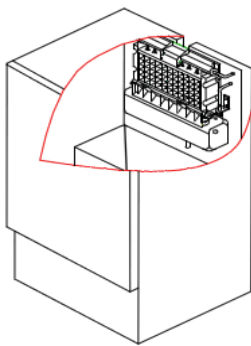

Freeze Cycle

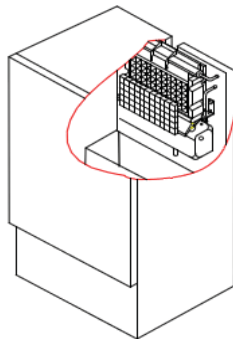

Harvest Cycle

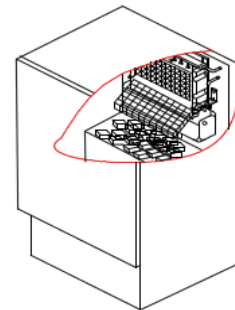

Bin Full Stage

### IMPORTANT:

- Never turn the water supply tap off when the ice maker is working.
- Never touch evaporator when unit is running.
- To promote proper ice formation and reduce melting, keep the ice maker door properly closed except when taking ice from the unit.

## Ice Maker Cycles

Your Ice Maker has two distinct cycles it will run.

- **Freeze:** During the freeze cycle, the compressor is pumping refrigerant, the fan motor is blowing air, and the water pump is circulating water. When the batch of ice has been fully formed, the ice maker stops and begins the Harvest cycle.

- **Harvest:** During the harvest cycle, the compressor is still operating, but the water pump has stopped. The ice cubes will slide off the evaporator into the storage bin, and the freeze cycle will restart when all the cubes have been harvested.

**NOTE:** A complete cycle of the two stages takes between 15 and 40 minutes, depending on temperature and operating conditions.

## How Your Ice Maker Uses Water

The ice maker begins with a fixed amount of water that is contained in the water trough. As the water flows to the freezing evaporator surface, the portion of water that does not contain mineral impurities freezes and sticks to the ice cube molds. The water containing impurities falls back into the water trough. During the ice making process, fresh water enters the water trough while the water in the trough freezes continuously in the evaporator.

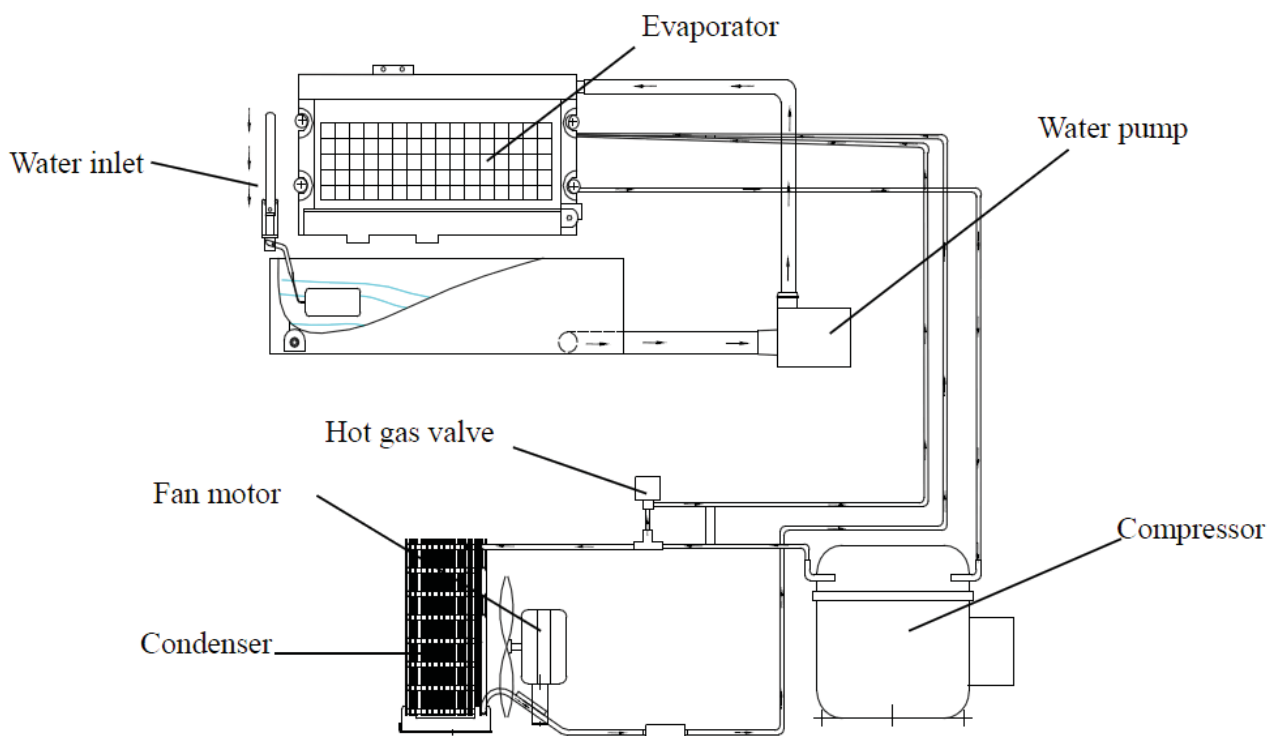

## Sounds

Your new ice maker may make sounds that are not familiar to you. Most of the new sounds are normal. Hard surfaces like the floor and walls can amplify the sound. Sounds may be caused by:

- Rattling noises coming from the flow of the refrigerant or the water line. Items stored on top of the ice maker can also make noises.
- The high-efficiency compressor may make a pulsating or high-pitched sound.
- Water running may make a splashing sound.
- You may hear air being forced over the condenser by the condenser fan.
- During the harvest cycle, you may hear the sound of ice cubes falling into the ice storage bin.

## CARE AND MAINTENANCE

Periodic cleaning and proper maintenance will ensure efficiency, top performance, and a long life for your ice maker. The maintenance intervals listed are based on normal conditions.

**NOTE:** Never keep anything in the ice storage bin that is not ice: objects like wine and beer bottles are unsanitary and labels may slip off and plug up the drain.

### Cleaning

Never use solvent based cleaning agents or abrasives on the interior of the unit. These cleaners may transmit taste to the ice cubes and damage or discolor the interior.

**Exterior:** The door and cabinet of the ice maker can be cleaned with a mild detergent and warm water solution. Use a soft sponge and rinse with clean water. Dry with a soft clean towel.

- **Interior:** The ice storage bin should be sanitized occasionally. The ice water trough should be cleaned before the ice maker is used for the first time and after an extended period of inactivity.
  - Unplug or disconnect the power supply to the unit.
  - Open the door and remove the removable ice storage bin. With a clean cloth, wipe the interior of unit and ice bin with a sanitizing solution made of 1 ounce of household bleach or chlorine and 2 gallons of hot (95°F–115°F) water.
  - Rinse thoroughly with clean water
  - Connect a hose to the drain outlet at the rear of the unit to drain water completely.
  - Replace the ice storage bin in the ice maker and then reconnect the power to the unit.
- **Condenser**

The condenser should be cleaned at least once every six months. A dirty or clogged condenser prevents proper airflow, reduces ice making capacity, and causes higher than recommended operating temperatures that may lead to component failure.

  - Unplug or disconnect the power supply to the unit.
  - Remove the two screws on the front cover and gently pull the cover off. Locate the condenser filter. This can be lifted out and cleaned with a brush or running water. Remove dirt and lint from the condenser fins and the unit compartment with the brush attachment of a vacuum cleaner. Do not touch the fins by hand as they are sharp.
  - Replace the filter and front cover, and then reconnect the ice maker to the power supply.
- **Water Distribution Tube**

When ice cubes are incompletely formed or the output of ice cubes is low, the water distribution tube may be blocked. Set the power switch to the OFF position, rotate the water distribution tube, locate the holes in the distribution tube and use a pointed object such as a toothpick to dredge the holes. Rotate the water distribution tube back to its original position. If the tube is badly blocked, clean it as follows:

  - Shut off the water supply and disconnect the water hose from the distribution tube.
  - Lift the right side up and then remove the distribution tube.
  - With a brush, clean the tube with a dilute solution of warm water and a mild detergent such as dishwashing liquid. After removing the dirt and lint from the surface, rinse the tube with clean water.
  - Replace the distribution tube and then reconnect the water supply.

- **Ice-making system**

Minerals removed from water during the freezing cycle will eventually form a hard, scaly deposit in the water system. Cleaning the system regularly helps remove the mineral scale build up. Hard water and a less effective filter may require the cleaning system to be cleaned more regularly, up to once every 6 months.

- Ensure that there is no ice on the evaporator. If ice is being formed, wait for the cycle to complete before turning the ice maker OFF.
- Remove all ice from the ice storage bin.
- Keep the ice maker connected to the water supply. Pour 8 oz. of Ice Maker Cleaning Solution (nickel-safe) into the water trough. Wait 5 minutes, then press the ON and Clean buttons at the same time. The Cleaning cycle will initiate and the unit will run the Automatic Clean Mode.
- The unit will complete the Cleaning cycle after 30 minutes, or the cycle can be stopped by pressing the Clean button again, after which the unit will progress to the freeze stage. Allow at least 20 minutes in Automatic Clean Mode for proper cleaning. After cleaning, press the ON/OFF switch again. Use a drain hose on the front of the water trough to drain off the waste water to a convenient container. Do not drain the waste water to the inside of the cabinet.
- Repeat steps 3 and 4 three times (without the Ice Maker Cleaning Solution) to rinse the ice making system thoroughly.
- Prepare a sanitizing solution made of 1 ounce of household bleach and 2 gallons of hot water (95° to 115°F). Wipe the entire bin inside and outside, covering the entire surface of the walls.
- Fill a spray bottle with the sanitizing solution and spray all corners and edges, making sure to cover all surfaces with the solution. Allow the solution to rest for 3 minutes, then wipe dry.
- Repeat step 3 and 4 once more to rinse the ice making system again.
- Set the Power switch to the ON position. The machine will return to the regular ice making mode. Discard the first batch of ice.

**IMPORTANT:** The Ice Maker Cleaning Solution contains acids. Do NOT use or mix with any other solvent-based cleaner products. Use rubber gloves to protect hands. Carefully read the material safety instructions on the container of the ice machine cleaner. Discard the first batch of ice produced after cleaning.

### **Long Term Storage or Relocation**

If you are intending to not use the ice maker for a long period of time, or want to relocate the ice maker, follow the steps below.

1. Shut off the water supply at the main source.
2. Disconnect the water supply line from the water inlet.
3. Shut off the electric supply at the main electrical power source.
4. Take out the ice storage bin to remove any remaining ice and water. Dry the bin.
5. Connect the drain hose to drain out any water, and then plug the drain outlet once complete.
6. Pull off the drainage tube of the water trough to drain off all water.
7. Leave the door open to allow for circulation and to prevent mold and mildew.
8. Leave water supply line and power cord disconnected until ready to reuse.





## PROBLEMS WITH YOUR ICE MAKER

Most common problems can be solved easily, saving you the cost of a possible service call. Try the following suggestions to see if you can solve the problem before contacting Vinotemp at [info@vinotemp.com](mailto:info@vinotemp.com).

### TROUBLESHOOTING GUIDE

PROBLEM	POSSIBLE CAUSE
Ice Maker does not operate	<ul style="list-style-type: none"> <li>• Ensure ice maker is plugged in to electrical outlet.</li> <li>• Check for a blown fuse and replace if necessary.</li> <li>• Check if the power button is on.</li> <li>• Remove any ice cubes and ensure ice-full probe is free of ice.</li> </ul>
Water does not feed in after Ice Maker starts	<ul style="list-style-type: none"> <li>• Turn on the water supply tap.</li> <li>• Reconnect the water supply line.</li> </ul>
Ice Maker makes ice but bin does not fill completely	<ul style="list-style-type: none"> <li>• Clean the condenser if dirty.</li> <li>• Check for proper air flow and ventilation.</li> <li>• Ensure that the ice maker is not near any heat source.</li> <li>• Ensure that the ambient temperature and water temperature is within the acceptable range.</li> </ul>
Water is leaking from the Ice Maker	<ul style="list-style-type: none"> <li>• Normal condensation or water may fall during ice removal.</li> <li>• Tighten the water supply connection to ensure no leakage.</li> <li>• Ensure drain pipe is not higher than drain outlet.</li> </ul>
Ice cubes are partially formed or white at the bottom	<ul style="list-style-type: none"> <li>• Check for proper water supply pressure.</li> <li>• Check if water supply or filter is restricted.</li> <li>• Check for a water leak at the water trough.</li> </ul>
Ice Maker makes noise during operation	<ul style="list-style-type: none"> <li>• Sounds may be normal, refer to “Sounds” (pg. 12).</li> <li>• Level and lock the feet to ensure level standing.</li> </ul>
Ice Maker stops suddenly while making ice	<ul style="list-style-type: none"> <li>• Check the power supply line.</li> <li>• Ambient temperature may be high. Disconnect the ice maker until the ambient temperature is within allowed range.</li> <li>• The ice storage bin may be full. Remove some ice cubes and ensure the ice-full probe is free of ice.</li> </ul>
Scaling occurs frequently	<ul style="list-style-type: none"> <li>• The hardness level of the water may be too high. Install a water-softening device in front of the water inlet.</li> </ul>
Water leaks from the ice storage bin	<ul style="list-style-type: none"> <li>• The drain hole below the ice storage bin may be blocked. Remove the ice storage bin and clean the drain hole.</li> <li>• The drain hose may be improperly placed higher than the floor of the ice storage bin. Check the hose to make sure water can drain without hindrance.</li> </ul>

## TERMS & CONDITIONS

Shipping/Delivery fees are the responsibility of the Purchaser. Seller is not responsible for the carrier's missed/Non delivery for any reason. Delivery is curbside. Optional upgrades in delivery service is an additional fee. If upgraded delivery service cannot be performed properly, Purchaser agrees to accept delivery curbside and the difference in upgraded cost will not be refunded. If item with free shipping/freight is canceled in transit, a charge of 25% of the price of the unit/s plus freight costs both ways will be charged. All damages must be noted at time of delivery on BOL and Seller to be notified within 48 hours of delivery of such damage. Purchaser acknowledges if cancelation is authorized by Seller, a 35% restocking fee and freight both ways will be charged. No cancelation or refund on made-to-order products. If an order has been placed and production has not started, cancellation fee of 15% of total amount will be charged. Cancelled orders paid by Credit Card will have an additional fee of 3% deducted from the total refund. Refurbished units are sold as is. Purchaser assumes risks to the quality and performance of goods and assumes the costs of all necessary service or repair not covered herein.

(Box here for check mark) Accept Terms & Conditions

Vinotemp International Corp. ("Seller") and the person or entity that acquires these goods from Seller ("Purchaser") hereby fully agrees to the following terms and conditions of the sale: **Shipping/Delivery** fees are the responsibility of the Purchaser whether freight prepaid or freight collect. Seller assumes responsibility for the goods sold to the Purchaser until the goods have reached Purchaser's delivery address (FOB Destination) and the delivery receipt is signed clear. Seller is not responsible for the carrier's late delivery, missed delivery, unpaved roads, remote locations, stairs, elevators, narrow door openings and other such issues in attempting to fit or deliver the goods into the Purchaser's location. Delivery to remote locations may require additional fees. Remote location may be defined at the discretion of the carrier as more or less than 50 miles from the nearest major city. Purchaser assumes all responsibility for additional costs related to freight such as access, measurement, installation, hookup, wiring, moving and storage of the goods, flight of stairs, carrier's inability to safely and/or adequately deliver, inability to use the building elevator to lift the goods, narrow openings, along with any additional costs to deliver or redeliver the product properly. Make sure to review access to the property and size of the product ordered. The transportation of all goods is subject to the terms and conditions which the carrier imposes on Purchaser. Installation is the responsibility of the Purchaser. If white glove delivery was ordered and cannot be performed properly, or access is hindered in any way, Purchaser agrees to accept delivery curbside (delivery service cannot be refunded). If Purchaser will-calls or pays for their own freight responsibility transfers to the Purchaser when the Purchaser or Purchasers freight company picks up the unit from Seller. Freight quoted are either curbside, threshold or white glove. Standard white glove delivery is main floor, easy access and NO STAIRS, Doors, aligned feet attached (if necessary) and removal of packaging, additional fees for additional requests. Each service has a different rate and will require additional fees. If freight is not charged (Free Shipping or Freight Included) and the order is cancelled after shipping, a freight charge of 25% of the cost of the unit, each direction will be charged. Item swap outs are arranged as curbside delivery and pickup unless noted otherwise. There is no white glove service for returns. Approved returns must



have original and/or proper packaging. Swap-outs (Delivery and Pick up are at the same time) Original unit must be packed and ready for carrier pick up at time of delivery of new unit. Packaging of old unit must be adequate for shipping, not oversized or on a pallet if unit was not originally delivered on a pallet. Carrier will not drop off new unit if the original unit is not ready. If the carrier has to make a second attempt, customer will be subject to additional charges for the attempted delivery and for any packaging issues. Deliveries include ONE attempt by the shipping company to deliver the product to the consumer. If for any reason the customer is unavailable to accept the order and the product is undeliverable under any circumstances, the customer will be responsible for any extra shipping and handling charges.

We are a manufacturer not a shipping company, deliveries are done by a 3rd party service. Email us at [info@vinotemp.com](mailto:info@vinotemp.com) for a quote or any additional information. Freight discussed is Continental USA (excluding Alaska, Puerto Rico, Hawaii), cost is additional please email [info@vinotemp.com](mailto:info@vinotemp.com) for a quote.

California **Proposition 65** Warning: The products sold on this ecommerce website and to the public may contain chemicals and other substances known to the State of California to cause cancer and birth defects and other reproductive harm.

Totes made of vinyl, imitation leather, and/or leather material contain lead and/or other substances that are known to the State of California to cause cancer, birth defects and other reproductive harm.

Microfiber "Plastic microfiber" means a small synthetic particle that is fibrous in shape, less than 5 millimeters in length, and is released into water through the regular washing of textiles made from synthetic material.

Composite wood: May contain formaldehyde.

Galvanized metal and some of its constituents contain lead and/or other substances that are known to the State of California to cause cancer, birth defects and other reproductive harm. Products made of vinyl contain lead, Diethyl Hexyl Phthalate (DEHP), and/or other substances that are known to the State of California to cause cancer, birth defects and other reproductive harm.

Acrylic may contain Acrylic Acid and/or other substances that are known to the State of California to cause cancer, birth defects, and other reproductive harm.

Appliances may contain tin or lead in either the paint or the controllers, and/or other substances that are known to the State of California to cause cancer, birth defects, and other reproductive harm.

Our barware items may contain plastic, acrylic, enamel, crystal, metal and/or other substances that are known to the State of California to cause cancer, birth defects, and other reproductive harm.

Appliances may contain Tin, Lead or Nickel

**Damage:** All damages must be noted at time of delivery. If a bill is signed that there is no damage, buyer accepts delivery as free and clear. Any claim for damages of the goods, when FOB Destination, that incurred during shipment by the carrier are insured and handled directly with the carrier by the Seller if noted on the receipt and notified within 48 hours of delivery. OPEN AND INSPECT YOUR DELIVERY. When FOB Destination, if the item is

damaged by the freight company, and Purchaser cancels rather than accepts a replacement, the order can be cancelled by paying for freight costs both ways and a 35% restocking fee for stocked items. No cancellation or refunds on custom/made or made to order products. When shipped 3rd Party (FOB Warehouse), Purchaser assumes all responsibility for delivery, payment of freight and freight claims for damages during shipment. Manufacture defects will be handled directly with Seller, subject to the limited warranty below.

**Fees:** All sales are final. Unless authorized in writing by the Seller, Purchaser may not return the goods under any circumstance. If Seller agrees in writing to take back stocked goods, there will be a restocking/service fee that is 35% of the purchase price of the goods and freight both ways (product must be new, unused, and in original packaging). If Purchaser returns goods claiming that the goods are defective and goods are found to be in working condition by the Seller, Purchaser is liable for the cost of freight both ways plus and a service fee that is 35% of the purchase price of the goods. Built to Order and Custom products are nonreturnable, nonrefundable. Purchaser must notify Seller of nonconforming goods within 48 hours of receipt, after which time all goods are deemed accepted by the Purchaser. If an order has been placed and production has not started, cancellation of your order will be a 15% charge. If Purchaser tenders payment with a check that has insufficient funds (NSF), a collection fee plus NSF fee of \$50 will be added to the invoice, which Purchaser agrees to pay promptly. If Purchaser puts a stop payment on a check or credit card for any reason, Purchaser agrees to pay for all costs associated with the Seller's collection or litigation of such a claim, including, without limitation, general and special damages, court costs and attorneys' fees. Finance charges begin the date of invoice. Title to the goods reverts back to the Seller in the case of nonpayment of goods or services. All fees and costs to retrieve the product, cost of freight, legal costs, collection fees and court fees, credit card fees and interest rate of 18% (annual rate) will be the responsibility of the Purchaser. In a credit card dispute, Purchaser assumes and must immediately pay any "credit card arbitration" fees and chargeback fees which the credit card companies charge at the time of the chargeback. Cancelled orders using a Credit Card will have an additional fee of 3% deducted from the refund. Any disputes not resolved within 30 days from the invoice date will be reported to credit reporting agencies.

**LIMITED WARRANTY:** Seller warrants that the goods will be free of defects in materials and workmanship as follows:

Furniture style (wood) wine cabinets made in the U.S.: all cooling unit parts only for a period of 1 (year) year; cabinetry and labor (uninstalled) for a period of 12 (twelve) Months (Model numbers "Vino" and "Custom").

Metal cabinet units (appliances) (compressor) (made in China and Denmark)(Model numbers start with EL, VT, IL, or EP: parts and labor for cooling system and cabinetry for a period of 12 (twelve) months.

Thermoelectric Units: 90 (ninety) days (including Wine and Beverage Coolers, Beer Dispensers, Humidor, Portofino Wood Cellars, and Refrigerators). (Models start with EL, VT, IL or EP). WineMate and Cellar Tec (WM, Wine Mate or CT)(Wine Cooling Units) Split and Ducted Systems and other installed cooling units are parts only for 1 year, no labor. Self Contained WineMate Cooling Systems are 1 year parts, 1 year labor. Removal and reinstallation of cooling units is not included.



Wine Accessories, Racking Systems, Parts and Other miscellaneous items is a 30 day warranty.

Il Romanzo units: Warranty 90 (ninety) days. Replacement part 12 (twelve) months from the date of sale.

Brama: 1 year warranty from date of purchase.

Non-New Units (Scratch & Dent/Refurbished/Floor Models), warranty for compressor units is 90 days from your dated invoice and 30 days for thermoelectric units (parts for function only, not cosmetic defects). These units are refurbished and sold as is; Purchaser assumes risks to the quality and performance of goods and assumes the costs of all necessary service or repair not covered herein. Extended warranties via New Leaf may not be purchased on Non-New Units. Delivery is curbside. Upgrades in delivery will require an additional fee.

Element Grills (via Element Products LLC), grills have a thirty day limited parts warranty on grill accessories.

If a model is not listed here will have 90 day warranty on parts only if it's a new item.

Parts and Repairs: Warranty on in-house repairs: 90 days parts and labor for compressor; 30 days parts and labor for Thermoelectric; Customer is required to put down a labor deposit of \$75 for Thermoelectric units; \$150 for compressor based Wine Coolers and \$195 for WineMate units which will be kept if a unit is found to be in good working condition. Customer is responsible for freight costs to us.

Warranty on parts purchased: 30 days; if part fails within 30 days of purchase, customer is to ship us back the part; upon inspection, if defective, VT will send replacement part at no charge.

If a purchaser claims a product is "defective" with regards to refrigeration, Purchaser must obtain a letter from a qualified refrigeration technician at the Purchaser's cost to verify that the unit was installed properly, with proper ventilation and the unit is truly malfunctioning due to a manufacturing defect.

Removal or reinstallation of a unit is not included in warranted costs. Purchaser's exclusive remedy is limited at Seller's option to repair or replace defective part[s] with either new or reconditioned part[s]. Purchaser is responsible for shipping the unit prepaid to a designated facility and Seller will pay return shipping charges in the continental United States for items repaired under warranty within 12 (twelve) months from date of sale. The returned unit must be packaged correctly, with enough protection to ensure the unit is not further damaged. Oversized or lack of packaging is not permitted and will be refused. Replacement or exchanged units will be returned to Purchaser through curbside delivery only. Any redelivery fees are the Purchasers responsibility. Since the natural variation in texture, density, grain, color, tone, and shade of wood is unavoidable; Seller does not guarantee the texture, color, tone, or shade of the wood: nor does seller guarantee the colorfastness of wood or against peeling, chipping, cracking, or scratching. Note: Unfinished wood is subject to warping; all wood surfaces must be sealed before placing cellar into service. Make sure doors are aligned by reviewing the owner's manual. Improper repair or placement of the unit will void the warranty. Any third party repair facility must be preapproved in writing by Seller, before providing replacement parts under warranty. Change Orders: Custom units already in production that require a change will be subject to a change order fee.

**Storage Fees:** When having an item serviced by a Vinotemp service technician at the Vinotemp facility, Purchaser agrees to pick up their repaired item or make arrangements for return shipping within a 30 day period once they have been notified by Vinotemp through phone call, email, or letter that their unit is ready for pick up. If the item remains in the Vinotemp warehouse after 30 days but no longer than 60 days, the Purchaser will incur additional storage fees of 2%. After 60 days in storage, the item will become property of Vinotemp. For custom units with deposits: If product is not picked up or shipped within 60 days of completion, Purchaser deposit is forfeited and product becomes the property of Vinotemp. Warranty period is from the date of sale (not from shipping, delivery, nor installation). All completed cabinetry, racking, or other custom work must be picked up or shipped within a period of 14 days after Vinotemp has notified the Purchaser by phone call, email, or letter. Any completed cabinetry, racking, or other custom work stored longer than 14 days will incur an additional monthly storage fee. After 60 days, the product will become property of Vinotemp.

This Limited Warranty does not cover damage due to such things as accident, misuse, abuse, mishandling, neglect, acts of God, fires, earthquakes, floods, high winds, government, war, riot or labor trouble, strikes, lockouts, delay of carrier, unauthorized repair, or any other cause beyond the control of the Seller, whether similar or dissimilar to the foregoing. Seller is not responsible for any damages caused to Purchaser's property resulting from the goods. This limited warranty applies only inside the Continental US (Alaska, Puerto Rico, Hawaii and other territories/countries are not warranted). Purchaser understands and acknowledges that the goods sold here are wine cellars, cigar humidors, and/or other similar units which house wine or cigars or other items. Purchaser assumes all risk of using these units, including risk of spoilage, humidity variations, temperature variations, leaks, fire, water damage, mold, mildew, dryness and similar and any other perils that might occur. Seller is not responsible for incidental or consequential damages, and there are no warranties, expressed or implied, which extend beyond the Limited Warranty described above. Warranty and liability are nontransferable. The implied warranties of merchantability and of fitness for a particular purpose are hereby expressly disclaimed. Some states do not allow the exclusion of incidental or consequential damages, or a waiver of the implied warranties of fitness and/or merchantability, so the above limitations may not apply to you. This warranty gives you specific legal rights and you may also have other rights which vary from state to state. Seller disclaims any indemnification for claims of infringement of any intellectual property of protectable nature. In the event of any dispute between Seller and Purchaser arising out of or relating to these terms and conditions or to the goods sold generally, Purchaser must first file a written claim with Seller within ten days of the occurrence giving rise to the claim and wait an additional thirty days for a response before initiating any legal action. The sale and all terms are subject to Nevada law. Any legal proceeding arising out of or relating to these terms and conditions or to the goods sold Purchaser shall bring, solely and exclusively in Clark County. In no event may Purchaser initiate any legal proceeding more than six months after the occurrence of the event giving rise to the dispute. Seller may make nonpayment claims until debt is paid in full. Any dispute or claim relating in any way to these to the Terms and Conditions, the Website, or any products or services sold or distributed by or through this Website, store, or catalog will be resolved by binding arbitration, rather than in court, except that you may assert claims in small claims court if your claims qualify. The



Federal Arbitration Act and federal arbitration law apply to the Terms and Conditions. We each agree that any dispute resolution proceedings will be conducted only on an individual basis and not in a class, consolidated or representative action. If for any reason a claim proceeds in court rather than in arbitration we each waive any right to a jury trial. Both parties agree to bring suit in court to enjoin infringement or other misuse of intellectual property rights.

The above terms and conditions are the only ones governing this transaction and Seller makes no oral representations of any kind. These Terms and Conditions can only be modified in writing, signed by both Purchaser and Seller.

**SPECIFIC WARRANTY BELOW for SCRATCH & DENT/OPEN BOX/ REFURBISHED/FLOOR MODELS/ CLOSEOUTS, OVERSTOCK: TERMS AND CONDITIONS OF SALE**

Vinotemp (and its brands Element, Wine Mate, Cellar Tec, Apex Wine Racks, Epicureanist II Romanzo, Brama("Seller") and the person of the entity that acquires these goods from Seller ("Purchaser") hereby fully agree to the following terms and conditions of the sale:

1. Freight: Vinotemp is not a freight, moving or installation company, if Freight is arranged for the Buyer, the Seller assumes no responsibility for the goods sold to the Purchaser once the goods have left the Seller's premises, including, but not limited to, late delivery by the moving carrier, or for events caused by any difficulty carrier incurs in attempting to fit the goods into the Purchaser's place of business or residence due to the size of the goods or otherwise, such as the disassembly and reassembly of the goods. Purchaser assumes all responsibility for delivery, payment of freight, extra fees, access, measurement, installation, hook-up, moving and storage of the goods. The transportation of all goods is subject to the terms and conditions which the moving carrier imposes on Purchaser including, but not limited to, additional charges imposed per flight of stairs, and/or additional charges resulting from the carrier's inability to safely and/or adequately use the building elevator to lift the goods to an upper floor. Any claim for damages incurred during shipment by the carrier of the goods are insured and handled directly with the carrier and must be noted at time of delivery.

2. All sales are final, and unless authorized in writing by the Seller, Purchaser is not entitled to return goods, under any circumstances. If Purchaser refuses to accept goods, the Purchaser is liable for the return and cost of freight both directions and a restocking/service fee that is 35% of the purchase price of the goods. Purchaser must notify Seller of non-conforming goods within four days of delivery, after which time all goods are deemed accepted.

3. If Purchaser tenders payment with a check that has insufficient funds (NSF), or stops payment on a check or credit card for any reason, Purchaser agrees to pay for all costs associated with the Seller's connection or litigation of such a claim, including without limitation extra damages, court costs, collection fees and attorney's fees. Finance charges begin the date of invoice. Collection fees plus NSF fee of \$50 will be added to your invoice, which you agree to promptly pay. Title to the goods does not pass until payment is received

in full by Seller and Seller retains a security interest in the goods until they are paid for in full. If the credit card dispute goes to arbitration, Buyer agrees to pay for credit card arbitration fees.

4. LIMITED WARRANTY on Non-New Units (Scratch & Dent/Refurbished and Floor Models): warranty for compressor units is 90 days from your dated invoice and 30 days for thermoelectric units (parts for function only, not cosmetic defects). These units are refurbished and sold as is; Purchaser assumes risks to the quality and performance of goods and assumes the costs of all necessary service or repair not covered herein. Wine Accessories, Racking Systems and other items not mentioned are not warranted. There is no warranty on parts purchased separately. Removal and re-installation of unit is not included in warranted labor. Purchaser's exclusive remedy is limited, at Seller's option; to repair or replace defective part[s] with either new or factory reconditioned part[s]. Purchaser is responsible for shipping the unit pre-paid to designated facility and Seller will pay return shipping charges in the continental United States for items repaired under warranty. Since the natural variation in texture, density, grain, color, tone and shade of wood is unavoidable; Seller does not guarantee the texture, color, tone or shade of the wood: nor does seller guarantee the colorfastness of wood or against peeling, chipping, cracking or scratching. Note: Unfinished wood is subject to warping; all wood surfaces must be sealed before placing cellar into service. Improper placement of the unit will void the warranty. By Vinotemp in writing, any 3rd party repair facility must be pre-approved before providing parts free of charge.

5. Freight: If As-Is unit is shipped including freight and delivery is denied, customer is responsible for freight to and from buyer. Other costs Buyer is responsible for is storage, repackaging, and attempted delivery fees.

6. Vinotemp does not cover damage due to such things as accident, misuse, abuse, mishandling, neglect, acts of God, fires, earthquakes, floods, high winds, government, war, riot or labor trouble, strikes, lockouts, delay of carrier, unauthorized repair, or any other cause beyond the control of the Seller, whether similar or dissimilar to the foregoing. Seller is not responsible for any damages caused to Purchaser's property resulting from the good. This limited warranty applies only inside the Continental US. (Alaska, Puerto Rico and Hawaii are not warranted.)

7. Purchaser understands and acknowledges that the goods sold here are wine coolers, appliances, cigar humidors, and/or other similar units which may house wine or cigars or other consumables. Purchaser assumes all risk of using these units, including risk of spoilage, humidity variations, temperature variations, leaks, fire, water damage, mold, mildew, dryness and similar perils that might occur.

8. UNLESS OTHERWISE PROVIDED BY APPLICABLE LAW, SELLER IS NOT RESPONSIBLE FOR INCIDENTAL OR CONSEQUENTIAL DAMAGES, AND THERE ARE NO WARRANTIES, EXPRESS OR IMPLIED, WHICH EXTEND BEYOND THE DESCRIPTION ON THE FACE HEREOF; WARRANTY AND LIABILITY ARE NON-TRANSFERABLE. THE IMPLIED WARRANTIES OF MERCHANTABILITY AND OF FITNESS FOR A PARTICULAR PURPOSE ARE HEREBY EXPRESSLY DISCLAIMED. SELLER DISCLAIMS ANY INDEMNIFICATION FOR CLAIMS OF INFRINGEMENT OF ANY INTELLECTUAL PROPERTY OF PROTECTABLE NATURE.





9. In the event of any dispute between Seller and Purchaser arising out of or relating to these terms and conditions or to the goods sold generally, Purchaser must first file a written claim with Seller within thirty days of the occurrence giving rise to the claim and wait an additional thirty days for a response before initiating any legal action. Any legal proceeding arising out of or relating to these terms and conditions or to the goods sold generally shall be brought solely in Clark County. The prevailing party in any such proceeding is entitled to its attorney's fees and costs. In no event may Purchaser initiate any legal proceeding more than six months after the occurrence of the event giving rise to the dispute.

**10. Delivery is curbside. Upgrades in delivery will require an additional fee.**

The above terms and conditions are the only ones governing this transaction and Seller makes no oral representations of any kind. These Terms and Conditions can only be modified in writing, signed by both Purchaser and Seller. 02/05/2019

## **SERVICE & IMPORTANT NOTICE**

Upon receipt and inspection of unit, the supply cord must be replaced if it is damaged. Contact our customer service at 1-800-777-8466 or [info@vinotemp.com](mailto:info@vinotemp.com).

The manufacturer has a policy of continuous improvement on its products and reserves the right to change materials and specifications without notice.

**WARNING:**  
**Please do not place the unit within reach of children.**  
**For adult use only.**

Contact **[info@vinotemp.com](mailto:info@vinotemp.com)** with any questions or visit  
**[www.vinotemp.com](http://www.vinotemp.com)**



732 S. Racetrack Road  
Henderson, HV 89015  
[www.vinotemp.com](http://www.vinotemp.com)

Vinotemp is a registered trademark of Vinotemp International. All products, features, and services are subject to change without notice. We cannot guarantee the accuracy of the contents of this document. We disclaim liability for errors, omissions, or future changes.

© 2020 Vinotemp International. All rights reserved.

PN:1866820003