

Use & Care MANUAL



5 SERIES Outdoor Gas Grills

VGBQ53024 / VGBQ53624 / VGBQ54224 / VGBQ55424 / VGIQ542241 / VGIQ554241
CVGBQ53024 / CVGBQ53624 / CVGBQ54224 / CVGBQ55424 / CVGIQ542241 / CVGIQ554241

Congratulations

We hope you will enjoy and appreciate the care and attention we have put into every detail of your new, state-of-the-art grill.

Your grill is designed to offer years of reliable service. This Use and Care Manual will provide you with the information you need to become familiar with the care and operation of your outdoor grill.

Your complete satisfaction is our ultimate goal. If you have any questions or comments about this product, please contact the dealer from whom you purchased it, or contact our Consumer Support Center at 1-888-845-4641.

We appreciate your choice of our outdoor grill and hope that you will again select our products for your other major appliance needs.

For more information about the complete and growing selection of products, visit us online at vikingrange.com. in the US or brigade.ca in Canada.

Table of Contents

Getting Started

Warnings & Safety	3
Features	6
Before Lighting Grill	7

Operation

Lighting Grill	8
Using Grill	9
Cooking Tips	10
Grilling Tips	11
Smoker Box	12
Rotisserie	12

Product Care

Cleaning and Maintenance	13
Troubleshooting	17
Service Information	18
Warranty	19

Warnings & Safety

Warning and Important Safety Instructions appearing in this manual are not meant to cover all possible conditions and situations that may occur. Common sense, caution, and care must be exercised when installing, maintaining, or operating the appliance.

ALWAYS contact the manufacturer about problems or conditions you do not understand.

Recognize Safety Symbols, Words, Labels

⚠ DANGER
Hazards or unsafe practices which WILL result in severe personal injury or death
⚠ WARNING
Hazards or unsafe practices which COULD result in death or severe personal injury
⚠ CAUTION
Hazards or unsafe practices which COULD result in minor personal injury. All safety messages will identify the hazard, tell you how to reduce the chance of injury, and tell you what can happen if the instructions are not followed.

Read and follow all instructions before using this appliance to prevent the potential risk of fire, electric shock, personal injury, or damage to the appliance as a result of improper usage of the appliance. Use appliance only for its intended purpose as described in this manual.

To ensure proper and safe operation: Appliance must be properly installed and grounded by a qualified technician. **DO NOT** attempt to adjust, repair, service, or replace any part of your appliance unless it is specifically recommended in this manual. All other servicing should be referred to a qualified servicer. Have the installer show you the location of the gas shutoff valve and how to shut it off in an emergency.

⚠ WARNING	
	EXPLOSION HAZARD
	Do not use the grill as storage area for flammable materials. Keep area clear and free from combustible materials, gasoline, and other flammable vapors and liquids. Failure to do so can result in death, explosion, or fire.

⚠ WARNING	
	ELECTRICAL SHOCK HAZARD
	This unit is equipped with a grounding plug for your protection against shock hazard and should be plugged directly into a properly grounded receptacle. Do not cut or remove the grounding prong from this plug. Keep all electric cords away from the heated surfaces of the grill.

⚠ WARNING
Before lighting the burners inspect the gas supply piping or hose. If there is evidence of cuts, wear, or abrasion, it must be replaced prior to use. Always keep your face and body as far away from the grill as possible when lighting.

⚠ WARNING
Do not use flammable cleaning materials. Use a flashlight to inspect the burner inlet to ensure it is not blocked. If obstructions can be seen, use a metal wire coat hanger that has been straightened out. Shake out any debris through the air shutter.

⚠ CAUTION
Handle the smoker box with care. The cover becomes extremely hot when being used. Use sturdy, properly insulated gloves or dry potholders.

Warnings & Safety

⚠ DANGER

If you smell gas

1. Shut off gas to the appliance.
2. Extinguish any open flames.
3. Open lid.
4. If odor continues, immediately call your gas supplier.

⚠ FOR YOUR SAFETY

1. Do not store or use gasoline or other flammable vapors and liquids in the vicinity of this or any other appliance.
2. Do not store any propane/butane cylinder (that is not connected for use) in the vicinity of this or any other appliance.

⚠ WARNING

TO PROTECT AGAINST ELECTRIC SHOCK

1. Do not immerse cord or plugs in water or other liquids.
2. Unplug from outlet when not in use and before cleaning.
3. Do not operate any outdoor appliance with a damaged cord, plug or after the appliance has malfunctioned. Contact the manufacturer for repair.
4. Do not let the cord hang over the edge or touch hot surfaces.
5. Use only extension cords with a 3-prong grounding plug; rated for the power of the equipment and approved for outdoor use with a W-A marking.

⚠ WARNING

To reduce the risk of fire, electric shock, or injury, read and follow these basic precautions before operating your gas grill.

- Your unit should be properly installed and connected to the gas for which it was designed. Do not use charcoal, wood chips, or other material in your grill. The smoker tray is the only area designed to hold wood chips or other smoke flavor enhancers.
- Have the technician show you the location of the gas shut-off valve so you can shut off the gas supply in an emergency. If you smell gas, the connections are not properly sealed or you may have a hole in the gas supply pipe or hose. Determining where the gas leak is should be left to a qualified technician. Warranty service must be performed by an authorized service agency.
- Children should not be left alone or unattended in an area where the gas grill is being used. Never allow children to sit, stand or play on or around the grill at any time. Do not store items of interest to children around the grill. Never allow children to crawl inside the cart or masonry enclosure.
- Use a covered hand when opening the hood and do so slowly to allow heat and steam to escape. To avoid burns when cooking, use long handled BBQ tools. Never lean over an open grill.
- Use sturdy, properly insulated gloves or potholders. Dish towels or other substitutes can become entangled, causing burns. Use dry potholders; wet potholders create steam and cause burns. Keep potholders away from open flames when lifting or moving utensils. Do not touch portions of the grill rack or burner grate with potholders until the hot surfaces have cooled.
- Only certain types of glass, heat-proof glass ceramic, earthenware, or other glazed utensils are suitable for grill use. These types of materials may break with sudden temperature changes. Use only on low or medium heat settings.
- Select the correct pan size for the burner. Be sure the pan is large enough to avoid boilovers or spillovers. This will save cleaning, and prevent accumulations of food, heavy splattering, or spillovers that can catch fire.
- **NEVER** leave the grill unattended. High flames and fatty meats will promote flare ups.
- When using the grill, do not touch the grill grates, open burner grates, or immediate surrounding areas. These surfaces become extremely hot and could cause burns. Be sure all controls are turned off and the unit has cooled before touching or cleaning any surfaces.
- **DO NOT** use aluminum foil to line drip pans or grill racks. This can upset combustion air flow or trap excessive heat in the control area, resulting in melted knobs.
- The handle of your cooking utensil should be positioned so that it does not extend over adjacent surface burners or interfere with closing the canopy. This will minimize burns, ignition of flammable materials, and possible spillage. Let hot pans cool in a safe place out of children's reach.
- **NEVER** grill without the drip tray in place. Make sure it is pushed all the way to the back—in proper position—to catch the drippings. Let the grease cool before attempting to remove for cleaning or disposal. Do not allow large amounts of grease to accumulate in the drip tray as it can catch on fire.
- Before storing, make sure the gas grill is cool. The gas must be turned off at the supply tank, removed, and stored outside in a well-ventilated area out of the reach of children.
- Keep all electric cords away from heated areas of the grill.
- When cooking in windy conditions, provide a wind break. Locate the unit with proper clearance from combustible surfaces.

Warnings & Safety

- Spiders and insects can nest in the burners of the grill and block the gas and air flow to the burner ports. This may cause a fire from behind the manifold cover. Inspect and clean the burners periodically.
- Keep the ventilation openings at the rear of the cart and cylinder enclosure free and clear to allow proper flow of air. Do not obstruct the flow of combustion and ventilation air.
- Clothing fires are potential hazards. Do not wear long flowing sleeves around the grill. They are easily caught on pan handles or ignited by burners and are generally in the way. Highly flammable clothing—especially synthetic fabrics—should not be worn while cooking.
- **DO NOT** heat any unopened glass or metal containers on the grill. Pressure may build up and cause the container to burst, resulting in serious personal harm or damage to the grill.
- **DO NOT** move the appliance during use.
- Be sure all controls are turned off and the grill is cool before using any type of aerosol cleaner on or around the grill. The chemical that produces the spraying action could, in the presence of heat, ignite or cause metal parts to corrode.
- If the following instructions are not followed exactly, a fire causing death or serious injury may occur.
 - Do not store a spare gas cylinder under or near this appliance.
 - Never fill the cylinder beyond 80 percent full.

CAUTION

This appliance is not intended for use by persons (including children) with reduced physical sensory or mental capabilities, or lack of experience and knowledge, unless they have been given supervision or instruction concerning use of the appliance by a person responsible for their safety. Children should be supervised to ensure that they do not play with the appliance.

WARNING

This unit is for outdoor use only! Do not operate in a building, garage or any other enclosed areas. This could result in carbon monoxide buildup which could result in injury or death.

Features

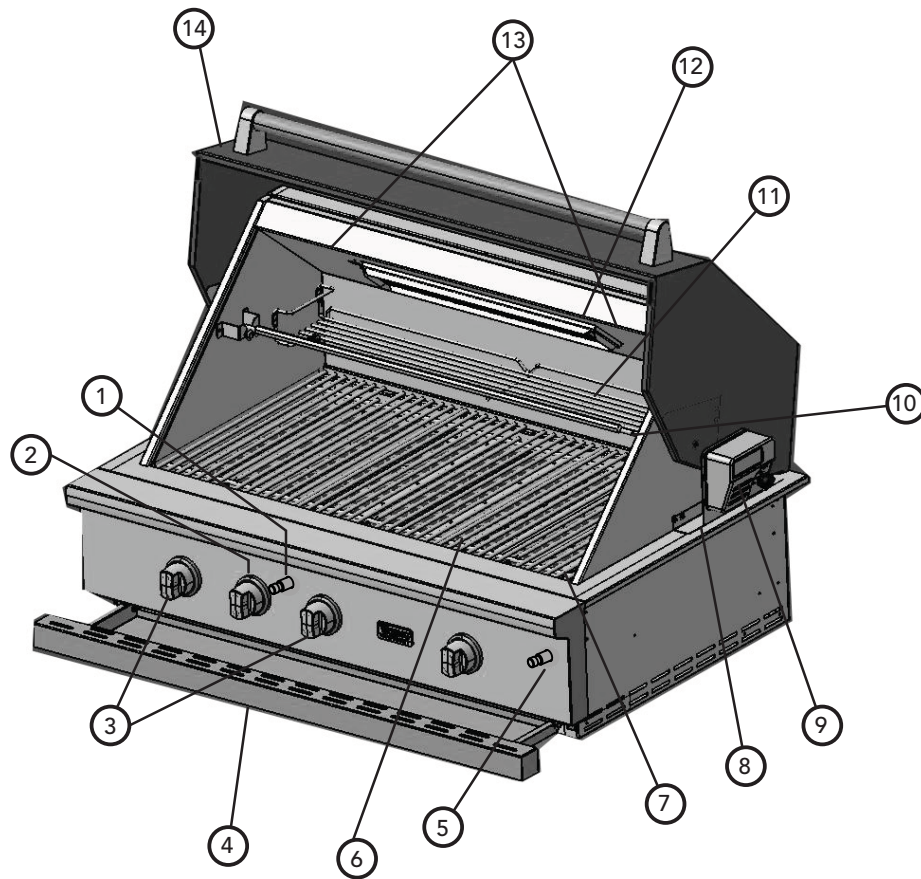

- | | |
|--|--------------------------------|
| 1. Electronic ignition | 10. Spit rod w/forks |
| 2. Rotisserie control knob | 11. Warming rack |
| 3. Grill burner control knobs | 12. Infrared rotisserie burner |
| 4. Pull out drip tray | 13. Interior lights |
| 5. Interior light switch | 14. Canopy |
| 6. Stainless steel grids w/ceramic
briquette trays underneath | |
| 7. Smoker box | |
| 8. Rotisserie bracket | |
| 9. Rotisserie motor | |

Note: Control locations will vary according to model.

Before Lighting Grill

Prior to turning on the gas, inspect the gas supply tubing or hose. Look for evidence of abrasion, cuts, wear and tear, or other damage which could require replacement prior to use. Make sure all burner control knobs are off. Do not attempt to light the burners if the smell of gas is present.

Check the connection with a soap and water solution after attaching the hose. Make sure there is gas in the tank and the tank is upright.

⚠ CAUTION

Wait at least five minutes before relighting a hot grill to allow any accumulated gas to dissipate. Keep a spray bottle of soapy water near the gas supply valve and check the connections for gas leaks before each use.

Briquette Trays Proper Installation

Note: The flash tube must be accessible through the plates. If the flash tube is not accessible, the trays are not properly installed.

Place center of briquette tray onto locating tab of the support brackets.

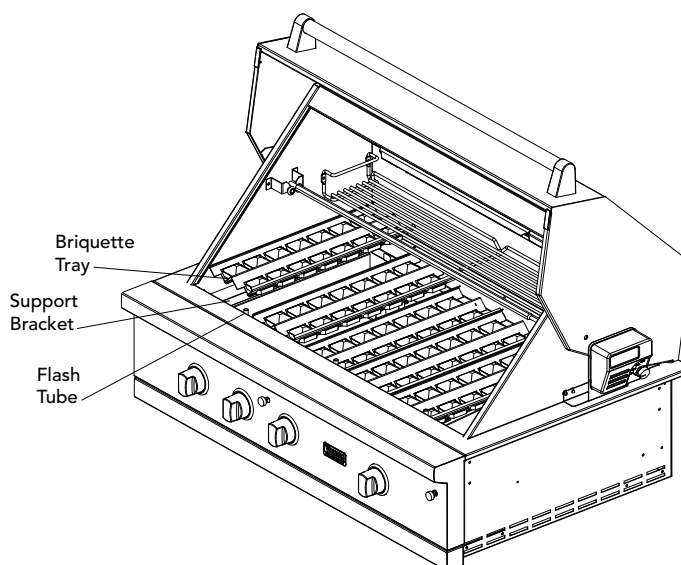

Using Grill with Outdoor Approved Hoods

- Outdoor approved hood models should be installed in a covered yet non-enclosed (well ventilated) area. Outdoor hoods aid greatly in smoke and odor removal, but should not be expected to eliminate entirely. They should also be protected from natural elements (such as rain) as much as possible.
- ALWAYS turn the outdoor hood to the "HIGH" position before lighting the grill.
- Keep the grill canopy closed as much as possible when cooking so smoke is exhausted out the back of the grill. This allows optimum performance of the hood.
- During breezy conditions, the performance of the outdoor hood may be compromised.

Lighting Grill

Lighting Grill Burners

Open the hood or remove covers. Push and turn the control knob until the "HIGH" position on the knob aligns with the indicator line on the control panel. **Press the electronic ignition button corresponding to the burner being lit.** You will hear a clicking sound. Turn the control knob to the desired setting. **If the burner does not light in 4 seconds, turn the knob to "OFF" and wait 5 minutes before trying again.** This will allow accumulated gas to dissipate. After several failed attempts the burner can be lit with a paper book match using the flash tubes. If you have just attempted to light the burner with the ignitor, allow 5 minutes for any accumulated gas to dissipate.

Lighting Grill Burners with Flash Tubes

Place the lit match through the grid next to the flash tube of the burner being lit. Keep your face as far away from the grill as possible. Make sure the match is adjacent to the flash tube. Push and turn the control knob until the "HIGH" position on the knob aligns with the indicator line on the control panel. Make sure you are turning the control knob that corresponds with the burner being lit. **If the burner does not light in 4 seconds, turn the knob to "OFF," wait five minutes, and try again.** If the burner will not light after several attempts, see the **Troubleshooting** section.

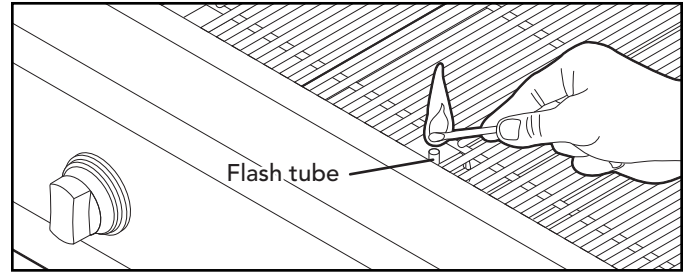

Lighting TruSear™ Infrared Burner (If Applicable)

Push in and turn the TruSear™ infrared control knob until the "HIGH" position on the knob aligns with the indicator line on the control panel. Once lit, turn the control knob to the desired setting. If the burner does not light within 4 seconds, release and turn the control knob to "OFF." Wait 5 minutes for any accumulated gas to dissipate and try again. After several failed attempts, the burner may be lit by turning the control knob to "HIGH" and dropping a match on the face of the burner. If the burner does not immediately ignite, turn the knob to "OFF", wait 5 minutes and try again.

Lighting the Grill Burners

Make sure the unit is plugged into a properly grounded receptacle. Turn the appropriate control knob counterclockwise to any position. This control is both a gas valve and an electric switch. Burners will ignite at any "ON" position with the automatic re-ignition system. If the flame goes out for any reason, the burners will automatically re-ignite if the gas is still flowing. When gas is permitted to flow to the burners, the electric igniters start sparking. On all surface igniters you should hear a clicking sound. If you do not, turn off the control and check that the unit is plugged in and that the fuse or circuit breaker is not blown or tripped.

Within a few moments, enough gas will have traveled to the burner to be able to light. When the burner lights, turn the burner control to any position to adjust the flame size. **If the burner does not light in four seconds, turn the knob to "OFF" and wait 5 minutes before trying again.** This will allow accumulated gas to dissipate. After several failed attempts the burner can be lit with a paper book match using the flash tubes.

Lighting Infrared Rotisserie Burner

The location of the infrared burner makes it more susceptible to strong wind conditions—more so than the protected grill burners. For this reason you should avoid using it during windy conditions.

Open the canopy. Push in and turn the rotisserie control knob until the "HIGH" position on the knob aligns with the indicator line on the control panel and continue to hold in the knob. Press the electronic ignition button which corresponds to the rotisserie control knob. You will hear a clicking sound. After the burner lights, hold the rotisserie control knob in about 5 seconds longer or until the burner remains lit. Once lit, turn the control knob to the desired setting. If the burner does not light within 4 seconds, release and turn the control knob to "OFF". **Wait 5 minutes for any accumulated gas to dissipate.** If the burner does not light after several attempts, then the burner can be lit by holding a lit match to the burner (with the control knob pushed in at the light position). Push and turn the control knob until the "HIGH" position on the knob aligns with the indicator line on the control panel. Make sure you are turning the control knob that corresponds with the burner being lit. If relighting a hot burner, wait 5 minutes. Never leave the rotisserie control knob at "ON" if rotisserie is not in use.

Using Grill

Before You Begin

- The first time you use the grill, turn the control knob to "HIGH" and preheat racks for an additional 15–20 minutes. This allows the grates to be "seasoned."
- Before each use, turn the control knob to "HIGH" and preheat for 5–7 minutes.
- Check to be certain the drip tray is in place.
- Light the grill burners using the lighting instructions.
- Place the food on the grill and cook to the desired doneness. Adjust heat setting, if necessary. The control knob may be set to any position between "HIGH" and "LOW."
- Allow grill to cool before cleaning. (Drip tray should be cleaned after each use.)

Canopy Thermometers

Your outdoor grill is equipped with a thermometer on the canopy. The thermometer is designed to aid in the preheating of the grill and closed canopy grilling.

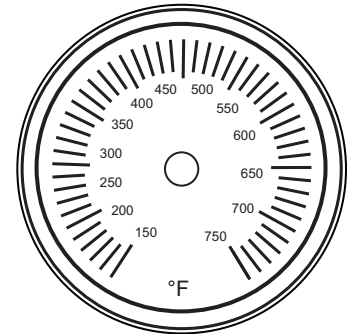

The estimated cooking temperatures with the canopy closed are:

WARM 150°F (65°C)
COLD SMOKE 150°F – 200°F (65°C – 93°C)
SMOKE 200°F – 300°F (93°C – 149°C)
GRILL 300°F – 750°F (149°C – 399°C)

Cooking Tips

Grilling can be either an open or closed canopy process. Open canopy grilling is excellent for foods requiring quick searing like steaks, burgers, chops, and hot dogs. Closed canopy grilling is similar to roasting in an oven. Food is cooked by heat reflection from the cover as well as heat from the burners below.

- When grilling chicken, roasts, well-done steaks or chops, and thick pieces of meat, sear on "HIGH." Then reduce the heat setting to prevent excessive flareup. This will allow the food to cook through without burning on the outside.
- When grilling large pieces of meat, use a meat thermometer to ensure that meats are either rare, medium or wellcooked.
- After steaks, chops, or hamburgers have been allowed to sear for approximately 1 minute, you might want to slide a spatula under the meat and turn it approximately 90° so that a waffle pattern will be seared onto the food.
- Use a metal spatula or tongs instead of a fork to turn the meat. A fork will puncture the meat, allowing juices to escape.
- Turn the meat over only once. Juices are lost when steaks, chops, or hamburgers are turned several times. The best time to turn the meat is after the juices have begun to bubble to the surface.
- To test for doneness, make a small slash in the center of the meat, not across the edge. This will prevent loss of juices.
- Occasionally there may be flare-ups or flames above the grill due to drops of fat falling onto the ceramic briquette trays. It is normal to have some flare-up during grilling. If necessary, use a long spatula to move food to another area until the flames subside.

Cooking Tips

Food	Weight or thickness	Control setting	Total suggested cooking time*	Special instructions and tips
BEEF				
Hamburgers	1/2" (1.3 cm) – 3/4" (1.9 cm)	Med	8 – 15 min.	Grill, turning once when juices rise to the surface. We suggest that ground chuck be used for hamburgers, as it will give you a juicier hamburger. Do not leave hamburgers unattended since a flare-up could occur quickly.
STEAKS				
Rib, club, sirloin, t-bone, porterhouse				Remove excess fat from edge. Slash remaining fat at 2" intervals to keep edges from curling. Grill, turning once
Rare 140°F/60°C	1" (2.5 cm) – 1-1/2" (3.8 cm)	High Med-High	8 – 12 min. 11 – 16 min.	Remove surface fat and fatty tissue. Fold over thin end to form uniformly thick piece. Bind with string. Grill, turning as needed to brown evenly. Brush often with melted margarine or oil.
Medium 160°F/71°C	1" (2.5 cm) – 1-1/2" (3.8 cm)	Med Med	10 – 12 min. 16 – 25 min.	
Well-done 170°F/77°C	1" (2.5 cm) – 1-1/2" (3.8 cm)	Med-High Med-High	20 – 30 min. 25 – 35 min.	
Tenderloin	5 lbs (0.3 kg)		30 – 40 min.	
POULTRY				
Chicken halves or quarters	2 lbs (0.9 kg) – 3 lbs (1.4 kg)	Med-High	1 – 1-1/2 hours 40 – 60 min.	Place skin side up. Grill, turning and brushing frequently with melted butter or oil.
PORK				
Chops	1/2" (1.3 cm) – 1" (2.5 cm)	Med Med	20 – 40 min. 35 – 60 min.	Remove excess fat from edge. Slash remaining fat at 2" intervals to keep edge from curling. Grill, turning once, and moving if necessary
Ribs		Med	45 – 60 min.	Grill, turning occasionally. During last few minutes brush with BBQ sauce, turn several times.
Ham steaks	1/2" (1.3 cm)	Med-High	12 – 15 min.	Remove excess fat from edge. Slash remaining fat at 2" intervals. Grill, turning once.
Hot dogs		Med	5 – 10 min.	Slit skin before cooking. Grill, turning once.
Fish				
Steaks Halibut Salmon Swordfish	3/4" – 1" (0.9 – 1.4 kg)	Med-High	5 – 10 min.	Grill, turning once. Brush with melted butter, oil, or marinade to keep fish moist.
Whole Catfish Trout	4 – 8 ounces (110 – 230 g)	Med-High	10 – 12 min.	Grill, turning once. Brush with melted butter, oil, or marinade to keep fish moist.
Vegetables				
Carrots	Whole	Med-Low	35 – 40 min.	Scrub, don't peel. Wrap in foil and lay directly on grill grate.
Onions	Whole	Low	20 min.	Butter, wrap in foil. Turn often.
Potatoes	Whole	Low	45 – 50 min.	Oil, wrap in foil. Turn often.
Zucchini, squash	Sliced (halves or quarters)	Med	30 min.	Butter lightly prevent sticking.

*These times are recommendations only. Variations in cuts of meats and personal taste may alter cooking times. Use your discretion when grilling.

Grilling Tips

TruSear™ Infrared Grilling Tips

Infrared grilling produces intense heat which quickly sears the meat. Searing locks in flavor and juices while allowing the outer surface to absorb smoke and food aroma that is produced as grease and drippings are vaporized by the burner. The result is a crisp, flavorful outside with a tender, juicy inside. As a general rule, foods will cook in about half the time they would take on an ordinary grill.

- Preheat the infrared burner for 2-3 minutes.
- Ensure that meat is fully thawed and that all excess fat is trimmed away prior to grilling.
- Leave the burner set on "HIGH" when placing food on the grill to sear.
- For thicker cuts of meats, adjust burner to a lower setting and continue cooking until desired doneness is reached.
- Allow burner to remain on "HIGH" 2-3 minutes after use to burn off any remaining food or drippings on the surface.

TruSear™ Infrared Cooking Chart

Food	Thickness	Control setting	Suggested cooking time*
Chicken breast, boneless	N/A	High Reduce to Med	2 – 3 mins. each side cook 8 – 10 mins. total Turn occasionally to prevent burning outside.
Hamburger	1/2 - 3/4" thick	High	2 mins. each side to sear. cook 6 – 8 mins. total. Turn occasionally to prevent burning.
Steaks, ribeye	1-1/2" thick	High	3 mins. each side for rare. 4 mins. each side for medium.
Steaks, filet	1" thick	High	3 mins. each side for rare to med. rare. 3-1/2 mins each side for medium.
Pork chops	3/4" thick	High	4 mins. each side.

**These times are recommendations only. Variations in cuts of meats and personal taste may alter cooking times. Use your discretion when grilling.*

Smoker Box

Using the smoker box feature intensifies the flavor by adding smoke to the grilling process. The additional smoke creates a “cloud” around the food which permeates meats and vegetables for added smoky flavor. In order to use the smoker box, remove the last set of stainless steel grids and briquette tray on the right hand side of the grill. Set the smoker box in the opening so that the front and rear tabs rest on the support brackets.

Wood Chip Use in Smoker Box

There are many wood chips available and selection is based on personal taste. The most common chips used are mesquite or hickory. Always soak the chips in water prior to putting them into the box. Use the “HIGH” position to start the chips smoking, then reduce the heat to a lower level to prevent them from drying out and flaming. If the wood chips do flame up, add a small amount of water to extinguish the flame. Use caution when adding water to a hot box to avoid steam burns. This tray may also be filled with water to produce steam. Whether smoking or steaming, the grill should remain closed as much as possible to maximize the effect.

During extended roasting periods, it is normal to add fresh wood chips and water to the box several times. Limit the amount of times the canopy is opened—each peek adds about 15 minutes to the cooking time.

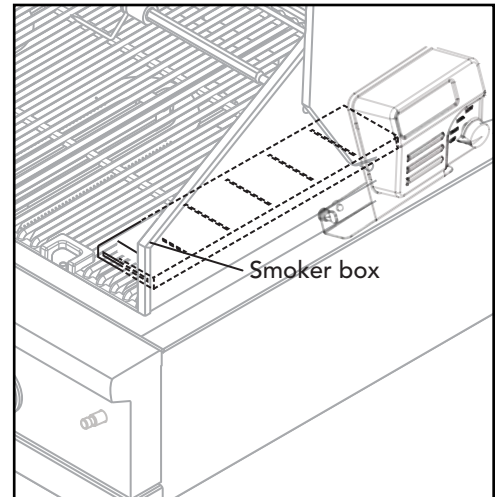

⚠ CAUTION

Handle the smoker box with care. The cover becomes extremely hot when being used. Use sturdy, properly insulated gloves or dry potholders.

Rotisserie

The rotisserie burner is an infrared burner which provides intense searing radiant heat. Preferred by professional chefs over other methods, this intense heat is great for searing in the natural juices and nutrients found in quality cuts of meat. Once lit, the rotisserie burner will reach cooking temperatures in about 1 minute. The red glow will even out in about 5 minutes.

To install the rotisserie motor, align the plate on the back of the motor with the mounting slot on the side of the grill. Tighten the thumb screw on the motor into the side of the grill. The skewer for the rotisserie is assembled by placing the pointed end into the rod socket inside the grill and resting the rounded end on the wheels on the left side of the grill.

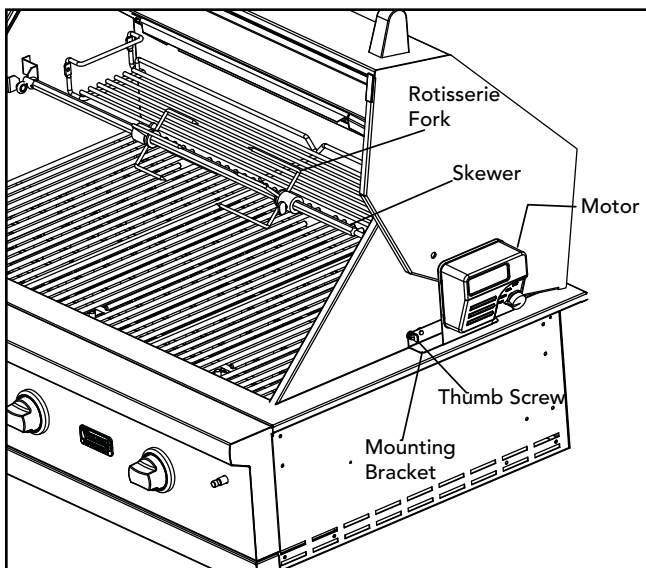

⚠ WARNING

ELECTRICAL SHOCK HAZARD

This unit is equipped with a grounding plug for your protection against shock hazard and should be plugged directly into a properly grounded receptacle. Do not cut or remove the grounding prong from this plug. **Keep the rotisserie motor electric cord away from the heated surfaces of the grill.**



Rotisserie

To load the skewer, slide one of the rotisserie forks (prongs facing away from the end) onto the skewer. Push the skewer through the center of the food, then slide the second rotisserie fork (prongs toward the food) onto the skewer. Center the product to be cooked on the skewer then push the forks firmly toward the food. Tighten the wing nuts with pliers. It may also be necessary to wrap the food with butcher's string to secure loose portions. Never use nylon or plastic string. Once the food is secure, insert the skewer into the motor. To turn on rotisserie motor, turn the knob to the desired speed.

If needed, remove the grill grates. Place the basting pan beneath the food. Keep canopy closed while using the rotisserie. Each peek adds about 15 minutes to the cooking time. A meat thermometer should be used when cooking large pieces of meat to ensure that the meats are rare, medium, and well cooked.

Rotisserie Cooking Chart

Food	Weight	Control setting	Suggested cooking time*	Internal temperature
Beef rib roast	4 – 6 lbs.	Med-High	Rare 14 – 16 min./lb.	145°F
			Medium 23 – 25 min./lb.	160°F
Bnls tip roast	4 – 6 lbs.	Med-High	Rare 14 – 16 min./lb.	145°F
			Medium 23 – 25 min./lb.	160°F
Bone-in pork butt	3 – 5 lbs	Med-Low	15 – 18 min./lb.	170°F
Bnls pork loin	3 – 5 lbs	Med	22 – 25 min./lb.	170°F
Smoked ham half	5 – 7 lbs	Med	22 – 25 min./lb.	170°F
Chicken Whole fryer Quarters	2 – 4 lbs	Med	25 – 30 min./lb.	180°F
		Med-High	20 – 22 min./lb.	180°F
Turkey Whole Breast	12 – 14 lbs	Med-High	16 – 18 min./lb.	180°F
	5 – 6 lbs	Med-High	22 – 25 min./lb.	170°F
Cornish hens	1-1/2 – 2 lbs.	Med	22 – 25 min./lb.	180°F

**The above information is given as a guide only. You may need to vary the heat settings and times due to factors such as weather, climate and/or personal requirements.*

Cleaning and Maintenance

Any piece of equipment works better and lasts longer when maintained properly and kept clean. Grilling equipment is no exception. Your grill must be kept clean and maintained properly. It is recommended to clean the grill after each use. A grill cover (sold separately) should also be strongly considered in order to protect your grill from the elements.

⚠ CAUTION

- **DO NOT** use a metal knife or any other metal tool to scrape stainless steel parts.
- **DO NOT** permit citrus or tomato juice to remain on stainless steel surfaces, as citric acid will permanently discolor stainless steel. Wipe up any spills immediately.
- **DO NOT** use abrasive cleaners, steel wool pads, or abrasive cloths on stainless steel, painted parts, or brass parts.

Stainless Steel Maintenance in Outdoor Environments

Viking outdoor grills are made of the finest grades of stainless steel. However, the stainless steel must be maintained properly over the life of the unit to preserve its elegant appearance and optimal performance. Below are some helpful tips:

- Wipe down any exterior grease spatters after each use of the grill.
- Regularly wipe down the exterior of the grill with a micro-fiber cloth.
- Use a designated stainless steel cleaner to clean and polish exterior surfaces. Some household cleaners are not suitable for stainless steel.
- Never place a cover on a damp grill. Make sure the grill is completely dry before covering.
- Under certain conditions, such as salty environments near a coastline, or around pools with high chlorine content, small amounts of surface rust may accumulate on stainless steel parts. Small amounts of surface rust can easily be removed by applying Soft Scrub® Gel to a damp sponge and wiping with the stainless steel grain. When dealing with hard to remove stains, use a non-metallic abrasive pad (A Scotch Brite pad for example) along with your stainless steel cleaner, and scrub in the grain direction of the stainless. It is important to wipe with the grain for the most efficient removal of staining.
- In extreme cases, it may be beneficial to apply a rust inhibitor coating to the exterior of the grill. Consult your local contractor before applying.

IMPORTANT: These tips will help you achieve the maximum life span of your grill. It is important to understand that stainless steel generally has a higher resistance to the effects of environmental exposure, but it will still be affected by the elements. Stainless steel has the potential to degrade just like all other architectural metals. The Limited Lifetime Warranty (page 33) covers rust through of stainless steel parts. It does not cover occasional surface rust and staining. It is important to follow the steps detailed above to guard against these natural occurrences and address them promptly should they arise.

Grill Grates

The grill grates are easily cleaned immediately after cooking is complete and before turning off the flame. Wearing a barbecue mitt to protect your hand from heat, use a stainless or brass bristle barbecue brush to scrub the grill grates. Dip the brush frequently in a bowl of water. Steam is created as the water contacts the hot grate. The steam assists the cleaning process by softening the food particles.

For thorough cleaning of the grates allow to cool, then soak 15 to 30 minutes in a hot water and detergent solution. After soaking, scrub with a teflon scouring pad.

Briquette Trays

IMPORTANT: It is critical that the briquette trays not be allowed to develop excess build-up of debris over an extended period. Otherwise flare-up may occur.

Flare-ups occur when meat is barbecued, and its fat and juices fall upon the hot surfaces. To control flare-ups, it is **ABSOLUTELY ESSENTIAL** to trim away excess fat from meat and poultry before grilling. Use cooking sauces and marinades sparingly, and try to avoid very cheap cuts of meat or meat products as these tend to have a high fat and water content. Also, the HI setting should primarily be used when lighting the grill and pre-heating it for grilling.

The briquettes normally burn clean during use, but it may be necessary to clean the briquette trays more thoroughly from time to time. After allowing the grill to cool, remove the grill grates, and then remove the briquette trays by lifting the front edge and pulling toward you. Set the trays upside-down on their mounting points, and operate the grill burners on high for 20-30 minutes. This will allow the trays to burn clean. If it becomes necessary to replace any or all of the briquette trays, replacement trays are available from your dealer.

Cleaning and Maintenance

Cleaning Your Grill Burners

Before removing the grates and burners, make sure the gas supply is off and the knobs are in the "OFF" position. To disassemble the grill for thorough cleaning, remove parts after they have cooled in the following order.

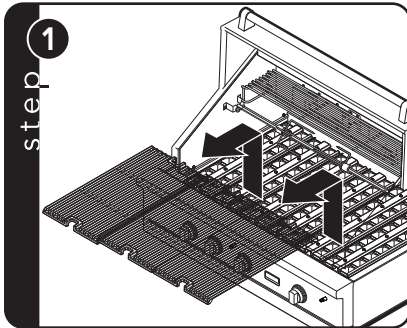

Remove grill grates.

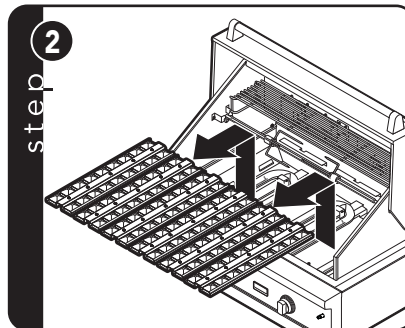

Remove ceramic briquette trays

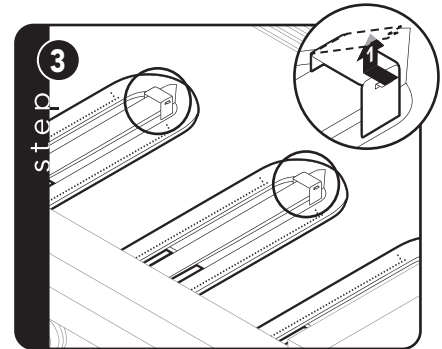

Unclip holding tab at the rear of each burner.

Note: Tabs may be sharp, wear gloves and use care when removing and reinstalling burner.

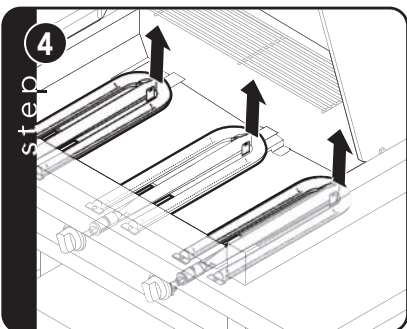

Remove burner from holding tab at rear of burner.

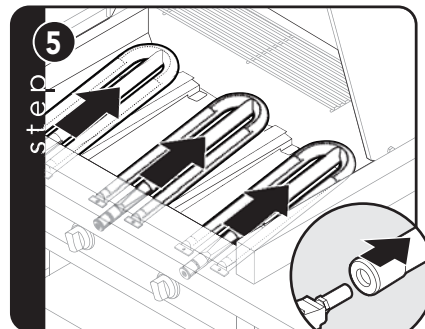

Remove burner from slots located in front mounting bracket.

Note: When reinstalling burner, verify that gas inlet opening of burner is over the gas orifice or injector.

Once the burners are removed, clean the exterior with a wire brush. Clear out any clogged ports with a straightened paper clip. **NEVER** use a toothpick or similar items as they may break off and clog the port. Shake out any debris through the air shutter. Use a flashlight to inspect the burner inlet to ensure it is not blocked. If obstructions can be seen, use a metal wire coat hanger that has been straightened out to clean. You also may use an air hose to blow out any debris that may remain.

WARNING

Do not use flammable cleaning materials. Use a flashlight to inspect the burner inlet to ensure it is not blocked. If obstructions can be seen, use a metal wire coat hanger that has been straightened out. Shake out any debris through the air shutter.

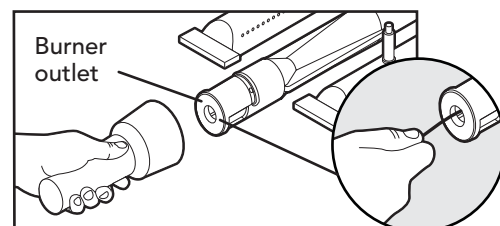

Cleaning and Maintenance

Spider Inspection

You should inspect the burners/venturi tubes at least once a year, or immediately if any of the following conditions occur.

- The smell of gas along with the burner flames appearing yellow.
- The grill does not reach the proper temperatures.
- The grill heats unevenly.
- The burners make a popping noise.

⚠ WARNING

SPIDER AND INSECT INFESTATION

Spiders and insects can nest in the burners/venturi tubes of this or any other grill, and cause the gas to flow from the front of the burner. This is a very dangerous condition that can cause a fire to occur behind the valve panel, thereby damaging the grill and making it unsafe to operate.

TruSear™ Infrared Grill Burner (If Applicable)

When finished cooking, turn the control knob to the "HIGH" setting and allow the burner to burn for 5 minutes. This helps eliminate any drippings or debris that would otherwise remain on the burner, degrading the performance and reducing burner life. After the 5 minute burn-off time, turn the grill "OFF" and allow to cool completely before attempting to clean or move. Wipe excess grease and food from grill surfaces.

Do Not use commercial oven cleaner on the TruSear burner. Only soap and water is recommended.

Drip Tray

The drip tray should be removed and cleaned after each use. Allow the drippings in the drip tray to cool completely before removing. To remove the drip tray, roll the tray all the way out. Lift up on the handle to fully remove the tray. Wash with hot, soapy water to clean. Dry and replace drip tray before next use.

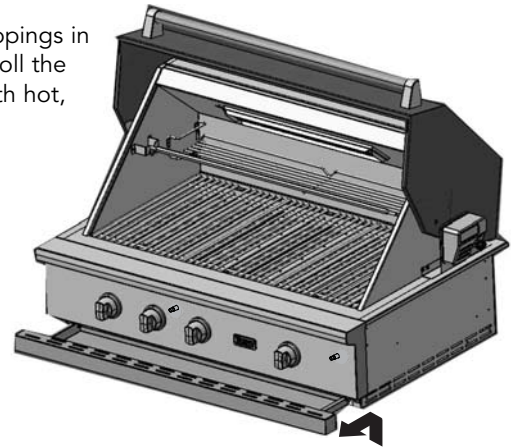

Infrared Rotisserie Burner

Special care is not required for the infrared rotisserie burner. It is designed as a self-contained unit. Do not attempt to clean it. Its own operation burns off any impurities which may condense on it.

Individual part cleaning chart

Part	What to use	How to clean
Stainless steel*	Mild detergent and warm water or stainless steel cleaner	Wipe with soft cloth or sponge. Use stainless steel cleaner to remove fingerprints and smudges. Rinse and dry thoroughly.
Grill Grates	Mild detergent and warm water or nonabrasive household cleaners.	Wipe with soft cloth or sponge. Rinse and dry thoroughly.
Briquette Trays	Mild detergent and warm water	Soak in warm water and mild detergent. For stubborn spots, scrub with stainless or brass bristle BBQ brush. Wipe down with heavy-duty cloth or sponge. Dry thoroughly.
Control knobs	Mild detergent and warm water or nonabrasive household cleaners. Do not soak.	Wipe with soft cloth or sponge. Rinse and dry thoroughly.

Cleaning and Maintenance

Replacing Interior Halogen Canopy Lights

⚠ CAUTION
DISCONNECT THE ELECTRIC POWER BEFORE REPLACING BULB.

DO NOT touch bulb with bare hands. Clean off any signs of oil from the bulb and handle with a soft cloth.

1. Unsnap glass light cover using a screwdriver in the access groove.
2. Firmly grasp light bulb and pull out.
3. Replace with halogen bulb using volt and wattage requirements listed on glass cover.
4. Replace the light cover by snapping glass cover onto metal box.
5. Reconnect power.

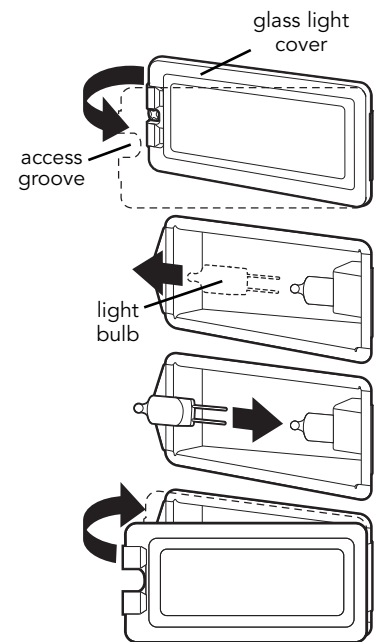

Troubleshooting

Problem	Possible cause and or remedy
Grill won't light when the ignitor is pressed	Make sure the control knob is off (no gas is on). Remove the grill rack and the ceramic briquette trays. Watch the ignitor tip. You should see a spark jump from the tip of the ignitor when the button is pressed. Do the other burners work? Make sure the ignitor tip is clean and free from debris.
Burner flame is yellow or orange and a gas odor is present	Check the burner inlet for obstructions. Check the air shutter for proper adjustment.
Low heat with knob on "HIGH"	Is the fuel hose bent or kinked? Is there adequate gas supply available? If only one burner appears low, does the orifice or burner need cleaning? Are any other gas appliances at the location below normal rate? Is the air shutter too far open or closed? Is the gas supply or gas pressure low?
Infrared burner will not light	Is there a spark at the thermocouple? Can you match light the burner?
Infrared burner lights, but will not hold flame once button is released	Is the thermocouple kinked or bent away from the burner? Readjust to lay flat against burner. Is the knob being depressed long enough? Hold button in until burner remains lit. Check for black spots on the infrared screen.
If your grill rotisserie should fail to operate	Is the electrical cord securely inserted in the electrical outlet? Is the circuit breaker open, or is a fuse blown?

Service Information

If service is required after checking the troubleshooting guide, call your authorized service agency.

When you make a service call, be sure to have the following information handy:

- Model Number
- Serial Number
- Date of Purchase
- Name of dealer from whom purchased

Be ready to clearly describe the problem that you are having with your grill.

If you are unable to obtain the name of an authorized service agency, or if you continue to have service problems, contact Viking Range, LLC at (888) 845-4641 or write to:

**VIKING RANGE, LLC
PREFERRED SERVICE
111 Front Street
Greenwood, Mississippi 38930 USA**

Record the following information indicated below. You will need it if service is ever required.

The serial number and model numbers for your grill is located underneath the pullout drip tray on the left hand side

Model No. _____ Serial No. _____

Date of Purchase _____ Date Installed _____

Dealer's Name _____

Address _____

If service requires installation of parts, use only authorized parts to insure protection under the warranty.

Keep this manual with your grill for future reference.

Warranty

PROFESSIONAL SERIES OUTDOOR GAS GRILL WARRANTY TWO YEAR FULL WARRANTY

Outdoor gas grills and all of their component parts, except as detailed below*, are warranted to be free from defective materials or workmanship in normal residential use for a period of two (2) years from the date of original retail purchase or closing date for new construction, whichever period is longer. Viking Range, LLC, warrantor, agrees to repair or replace, at its option, any part which fails or is found to be defective during the warranty period.

***FULL NINETY (90) DAY COSMETIC WARRANTY:** Decorative items (including ceramic briquettes) are warranted to be free from defective materials or workmanship (such as scratches on stainless steel, porcelain blemishes, etc.) for a period of ninety (90) days from the date of original retail purchase. ANY DEFECTS MUST BE REPORTED TO THE SELLING DEALER WITHIN NINETY (90) DAYS FROM DATE OF ORIGINAL RETAIL PURCHASE. Viking Range, LLC uses the most up-to-date processes and best materials available to produce all finishes. However, slight color variation may be noticed because of the inherent differences in porcelain parts as well as differences in lighting, product locations, and other factors. Therefore, this warranty does not apply to variations attributable to such factors.

***FULL NINETY (90) DAY WARRANTY IN "RESIDENTIAL PLUS" APPLICATIONS:** This full warranty applies to applications where use of the product extends beyond normal residential use, but the warranty period for products used in such applications is ninety (90) days. Examples of applications covered by this warranty are bed and breakfasts, fire stations, private clubs, churches, yachts, etc. Under this "Residential Plus" warranty, the product, its components and accessories are warranted to be free from defective material or workmanship for a period of ninety (90) days from the date of original retail purchase. This warranty excludes use of the product in all commercial locations such as restaurants, food service locations and institutional food service locations.

FIVE YEAR LIMITED WARRANTY

Any burner assemblies, TruSear™ infrared burner, infrared rotisserie burner, or porcelain grill grate which fails due to defective materials or workmanship in normal household use during the second through fifth year from the date of original retail purchase will be repaired or replaced, free of charge for the part itself, with the owner paying all other costs, including labor. Corrosion, scratching, and discoloration due to improper use and care of the outdoor product is excluded from this warranty.

TERMS AND CONDITIONS

This warranty extends to the original purchaser of the product warranted hereunder and to each transferee owner of the product during the term of the warranty and applies to products purchased and located in the United States, Canada, Mexico, and the Caribbean, (excluding Cuba, Dominican Republic, and Haiti). Products must be purchased in the country where service is requested. If the product or one of its component parts contains a defect or malfunction during the full warranty period after a reasonable number of attempts by the warrantor to remedy the defect or malfunction, the owner is entitled to either a refund or replacement of the product or its component part or parts. Replacement of a component part includes its free installation, except as specified under the limited warranty. Under the terms of this warranty, service must be performed by a factory authorized Viking Range, LLC service agent or representative. Service will be provided during normal business hours, and labor performed at overtime or premium rates shall not be covered by this warranty.

Owner shall be responsible for proper installation, providing reasonable and necessary maintenance, providing proof of purchase upon request, and making the appliance reasonably accessible for service. The return of the Owner Registration Card is not a condition of warranty coverage. You should, however, return the Owner Registration Card so that Viking Range, LLC can contact you should any question of safety arise which could affect you.

This warranty gives you specific legal rights, and you may also have other rights which may vary from jurisdiction to jurisdiction.

WHAT IS NOT COVERED BY THIS WARRANTY: This warranty shall not apply to damage resulting from abuse, failure to provide reasonable and necessary maintenance, accident, delivery, negligence, natural disaster, loss of electrical power to the product for any reason, alteration, outdoor use, improper installation, improper operation, or repair or service of the product by anyone other than an authorized Viking Range, LLC service agency or representative. This warranty does not apply to commercial usage.

LIMITATION OF REMEDIES AND DURATION OF IMPLIED WARRANTY

OWNER'S SOLE AND EXCLUSIVE REMEDY FOR A CLAIM OF ANY KIND WITH RESPECT TO THIS PRODUCT SHALL BE THE REMEDIES SET FORTH ABOVE. VIKING RANGE, LLC IS NOT RESPONSIBLE FOR CONSEQUENTIAL OR INCIDENTAL DAMAGE, INCLUDING BUT NOT LIMITED TO FOOD OR MEDICINE LOSS, DUE TO PRODUCT FAILURE, WHETHER ARISING OUT OF BREACH OF WARRANTY, BREACH OF CONTRACT OR OTHERWISE. Some jurisdictions do not allow the exclusion or limitation of incidental or consequential damages, so the above limitation or exclusions may not apply to you. **ANY IMPLIED WARRANTIES OF MERCHANTABILITY OR FITNESS FOR A PARTICULAR PURPOSE APPLICABLE TO THIS PRODUCT ARE LIMITED IN DURATION TO THE PERIOD OF COVERAGE OF THE APPLICABLE EXPRESS WRITTEN LIMITED WARRANTIES SET FORTH ABOVE.** Some states do not allow limitations on how long an implied warranty lasts, so the above limitation may not apply to you.

WARRANTY SERVICE

To obtain warranty service, contact an authorized Viking Range, LLC service agent, or Viking Range, LLC, 111 Front Street, Greenwood, Mississippi 38930, (888) 845-4641. Provide model and serial number and date of original purchase or closing date for a new construction. For the name of your nearest authorized Viking Range, LLC service agency, call Viking Range, LLC. **IMPORTANT:** Retain proof of original purchase to establish warranty period.

Specifications subject to change without notice.

Viking Range, LLC
111 Front Street
Greenwood, Mississippi 38930 USA
(662) 455-1200

For product information,
call 1-888-(845-4641)
or visit our web site at vikingrange.com in the US
or brigade.ca in Canada