

Installation Guide



5 Series
Professional Built-in Bottom-Freezer and
Side-By-Side Refrigerator/Freezer

Table of Contents

Warnings and Important Information _____	3
Professional Bottom-Freezer	
Dimensions _____	6
Specifications _____	7
Cutout Dimensions _____	8
Anti-Tip Dimensions (36") _____	9
Cabinet Information (Professional) _____	10
Cabinet Information (Professional with flush mount trim) _____	11
Custom Side Panel Dimensions (Professional) _____	12
Custom Side Panel Dimensions (Professional with flush mount trim) _____	13
General Information _____	14
Unpacking & Moving _____	16
Flush Mount Side Trim Installation _____	17
Installation _____	17
Hinge Adjustment _____	18
Kickplate Installation _____	21
Door Stop Adjustment _____	21
System Specifications and Data _____	22
Final Installation _____	23
Performance Checklist _____	24
Control Panels _____	25
Service & Registration _____	26

IMPORTANT – Please Read and Follow!

- Make sure that incoming voltage is the same as unit rating. An electric rating plate specifying voltage, frequency, wattage, amperage, and phase is attached to the product.
- To reduce the risk of fire, electrical shock, or injury to persons, installation work and electrical wiring must be done by a qualified technician in accordance with all applicable codes and standards, including fire-rated construction.
- The installer should leave these instructions with the consumer who should retain them for local inspector's use and for future reference.

Your safety and the safety of others is very important.

We have provided many important safety messages in this manual and on your appliance. **ALWAYS** read and obey all safety messages.



This is the safety alert symbol. This symbol alerts you to hazards that can kill or hurt you and others.

All safety messages will be preceded by the safety alert symbol and the word "DANGER" or "WARNING." These words mean:

DANGER

You will be killed or seriously injured if you don't follow instructions.

WARNING

You can be killed or seriously injured if you don't follow instructions.

All safety messages will identify the hazard, tell you how to reduce the chance of injury, and tell you what can happen if the instructions are not followed.

IMPORTANT – Please Read and Follow!

A GFI shall be used if required by NFPA-70 (National Electric Code), federal/state/local laws, or local ordinances.

- The required use of a GFI is normally related to the location of a receptacle with respect to any significant sources of water or moisture.
- Viking Range, LLC will **NOT** warranty any problems resulting from GFI outlets which are not installed properly or do not meet the requirements below.

If the use of a GFI is required, it should be:

- Of the receptacle type (breaker type or portable type **NOT** recommended)
- Used with permanent wiring only (temporary or portable wiring **NOT** recommended)
- On a dedicated circuit (no other receptacles, switches or loads in the circuit)
- Connected to a standard breaker of appropriate size (GFI breaker of the same size **NOT** recommended)
- Rated for Class A (5 mA +/- 1 mA trip current) as per UL 943 standard)
- In good condition and free from any loose-fitting gaskets (if applicable in outdoor situations)
- Protected from moisture (water, steam, high humidity) as much as reasonably possible

IMPORTANT – Please Read and Follow!

It is your responsibility to:

- comply with installation specifications and dimensions.
- properly install unit.
- remove any moldings or decorative panels that prevent the unit from being serviced.
- make sure that you have these materials (not provided with your unit), which are necessary for proper installation:
 - 1/4" (6 mm) copper tubing with shutoff valve
 - 6– #8 x 3" (7.6 cm) wood screws (longer screws may be required)
 - 1– Saddle valve (do not use self-piercing feature of the valve)
- assure that floor will support unit, door panels and contents (approximately 1200 pounds [540 kg]).
- provide a properly grounded electrical outlet.
- assure that location will permit appliance doors to open 90° minimum.

⚠ WARNING



ELECTRICAL SHOCK HAZARD
Disconnect power or turn power disconnect switch to OFF position before removing top grille. Failure to do so can result in death or electrical shock.

⚠ WARNING



TIP OVER HAZARD
Appliance is top heavy and tips easily when not completely installed. Keep doors closed until appliance is completely installed and secured per installation instructions.
Use two or more people to move and install appliance. Failure to do so can result in death or serious injury.

Most of the unit's weight is at the top. Extra care is needed when moving the unit to prevent tipping. Use cardboard shipping material or plywood under unit until it is installed in the operating position to protect floor surface.

Dimensions (Bottom-Freezer)

36" Bottom-Freezer

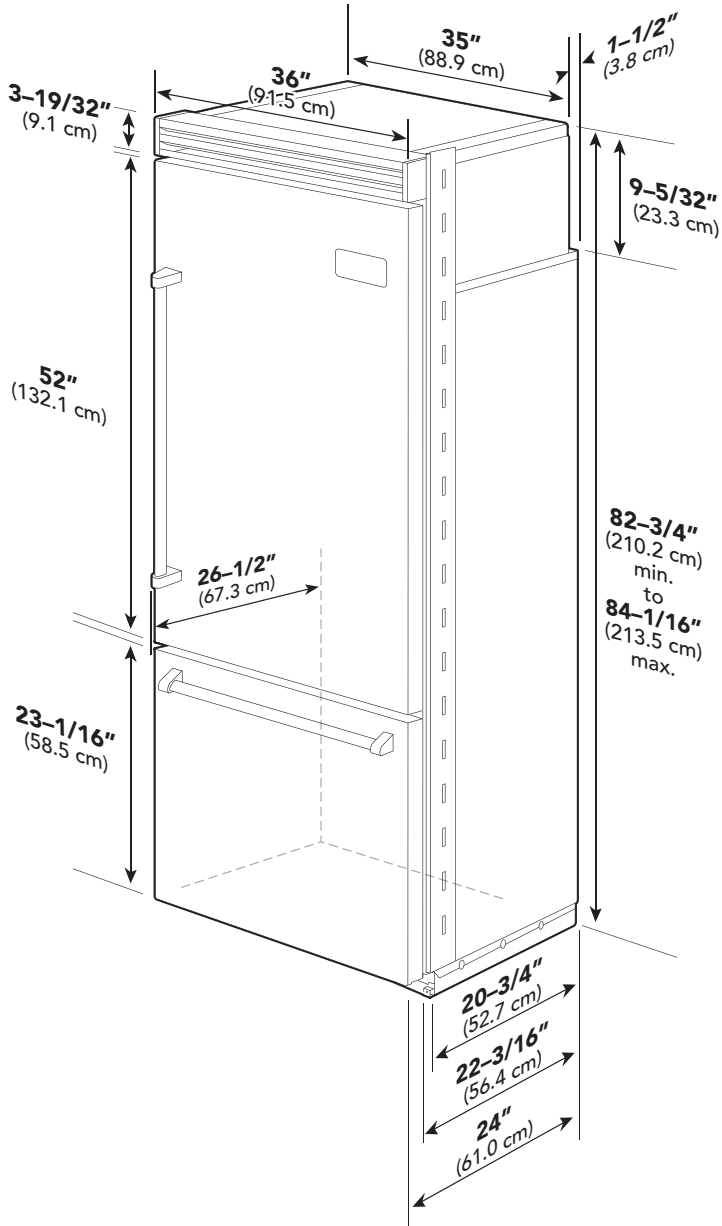

36" Bottom-Freezer with Flush Mount Trim

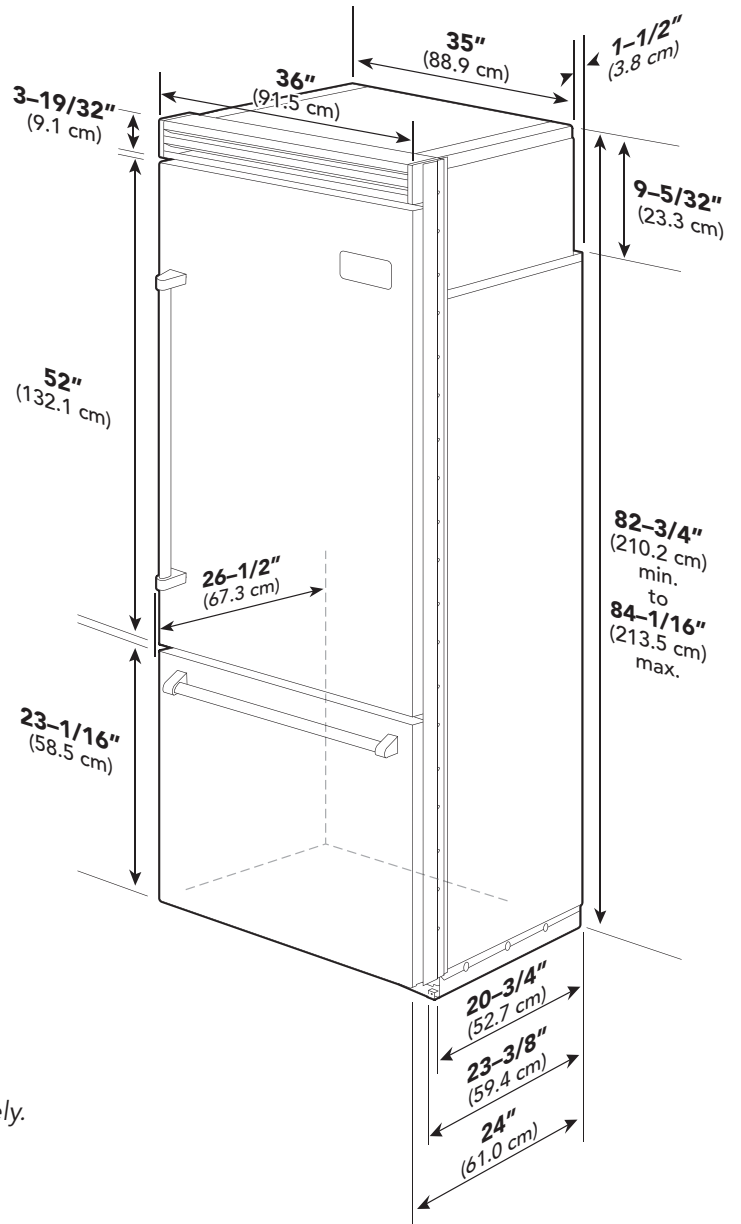

Note: Flush Mount Trim (PBIRFTKSS) purchased separately.

Specifications (Bottom-Freezer)

36" Bottom Freezer	
Description	VCBB/CVCBB
Overall width	36" (91.5 cm)
Overall height (from bottom)	82-3/4" (210.2 cm) min. to 84-1/16" (213.5 cm) max.
Overall depth from rear	To front edge of side trim: 22-3/16" (56.4 cm) To front of top grille: 24" (61.0 cm) To front of handle endcap: 26-1/2" (67.3 cm)
Cutout width	35-5/8" (90.5 cm) min. to 35-3/4" (90.8 cm) max.
Cutout height	82-7/8" (210.5 cm) min. to 84-1/16" (213.5 cm) max.
Cutout depth	24" (61.0 cm) min.
Electrical requirements	115 volt, 60 Hz, 15 amp dedicated circuit; 3-wire cord with grounded 3-prong plug attached to product
Maximum amp usage	9.9 amps
Inlet water requirements	1/4" copper tubing inlet waterline; minimum 20 psi; maximum 120 psi
Overall interior dimensions	
Refrigerator	15.3 cu. ft. (434 liters)
Freezer	5.1 cu. ft. (145 liters)
Total capacity	20.4 cu. ft. (579 liters)
Approximate shipping weight	565 lbs. (254.3 kg)

36" Bottom Freezer with Flush Mount Trim	
Description	VCBB/CVCBB Flush Mount
Overall width	36" (91.5 cm)
Overall height (from bottom)	82-3/4" (210.2 cm) min. to 84-1/16" (213.5 cm) max.
Overall depth from rear	To front edge of side trim: 23-3/8" (59.4 cm) To front of top grille: 24" (61.0 cm) To front of handle endcap: 26-1/2" (67.3 cm)
Cutout width	36" (91.5 cm)
Cutout height	82-7/8" (210.5 cm) min. to 84-1/16" (213.5 cm) max.
Cutout depth	24" (61.0 cm) min.
Electrical requirements	115 volt, 60 Hz, 15 amp dedicated circuit; 3-wire cord with grounded 3-prong plug attached to product
Maximum amp usage	9.9 amps
Inlet water requirements	1/4" copper tubing inlet waterline; minimum 20 psi; maximum 120 psi
Overall interior dimensions	
Refrigerator	15.3 cu. ft. (434 liters)
Freezer	5.1 cu. ft. (145 liters)
Total capacity	20.4 cu. ft. (579 liters)
Approximate shipping weight	565 lbs. (254.3 kg)

Cutout Dimensions (Bottom-Freezer)

36" Bottom-Freezer

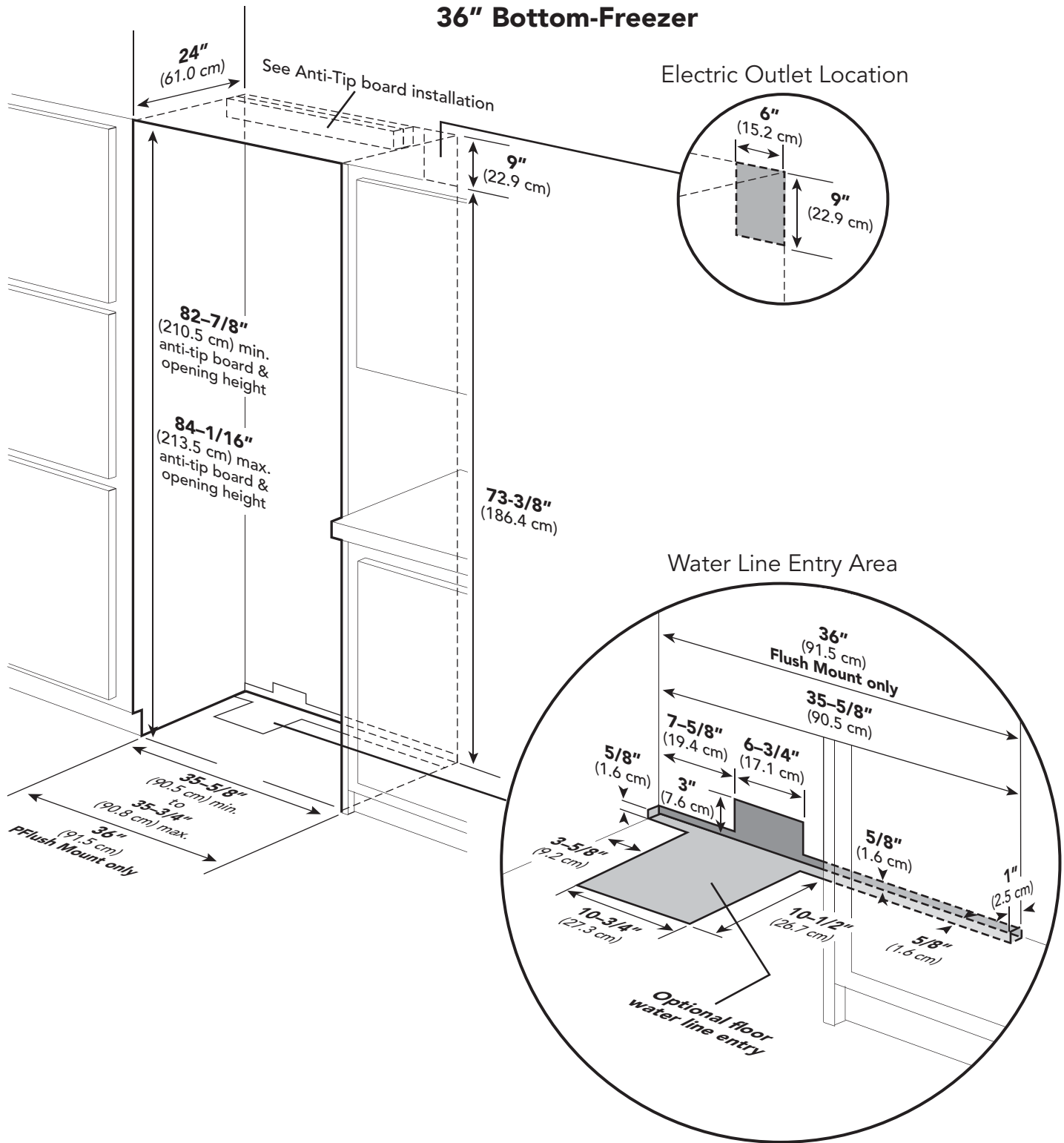

Anti-Tip Dimensions (Bottom-Freezer)

36" Bottom-Freezer

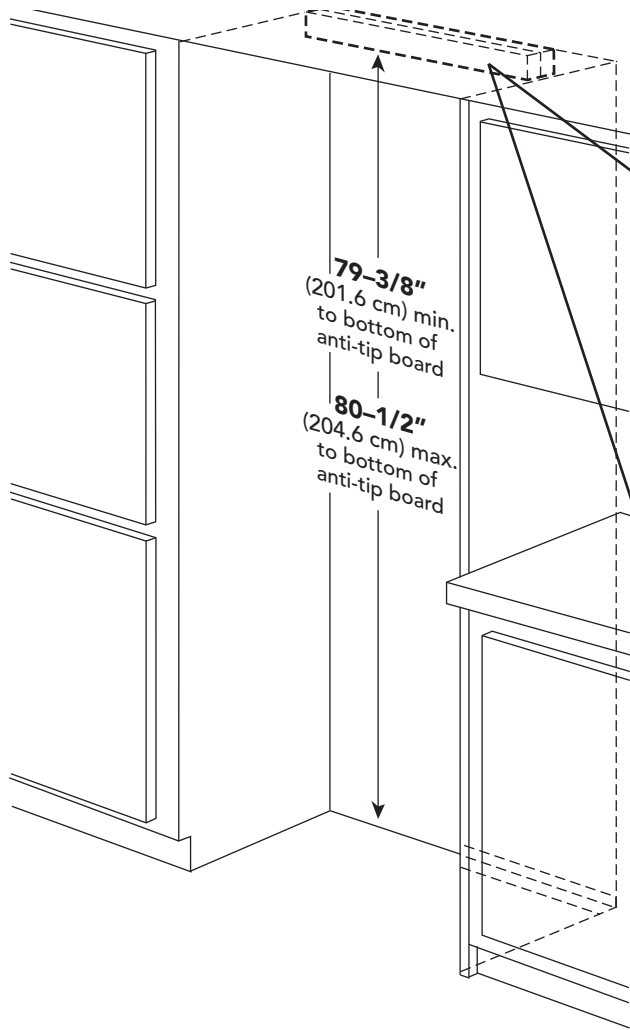

Anti-Tip Location

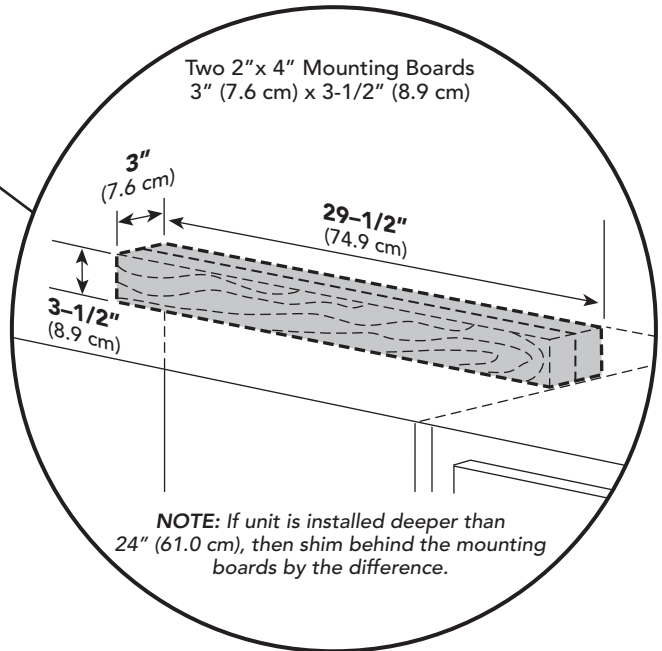

Flush Mount Anti-Tip Location

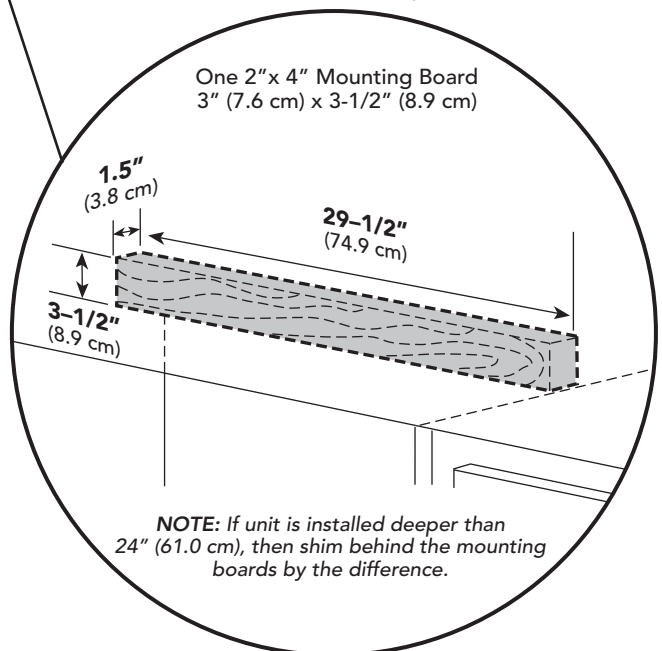

Bottom of anti-tip board is 3-7/8" (9.8 cm) below opening height.
NOTE: Top of unit must be placed firmly under anti-tip board.

Cabinet Information (Professional)

Professional models fit "semi-flush" in standard 24" (61.0 cm) deep cabinet openings. The door face protrudes 1-3/4" (4.4 cm) from the cabinet face. The handle protrudes an additional 2-1/2" (6.4 cm) into the room.

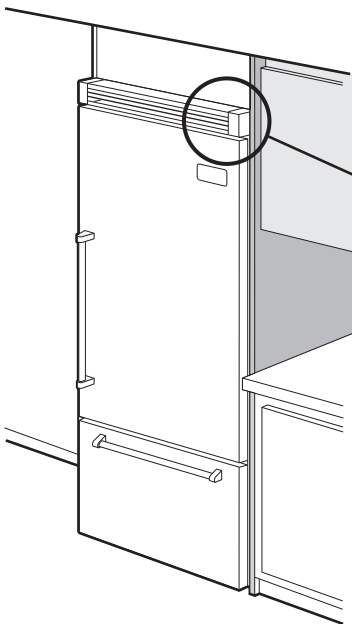
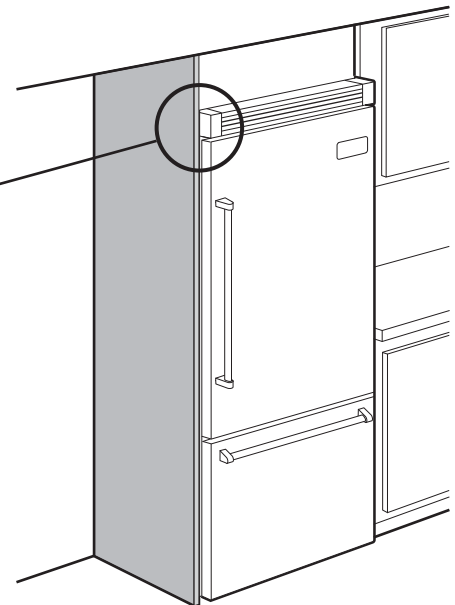
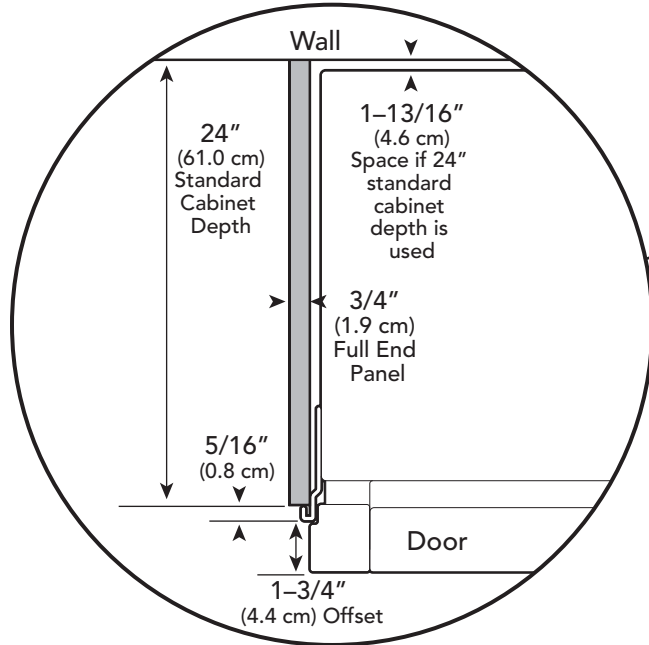

Top View

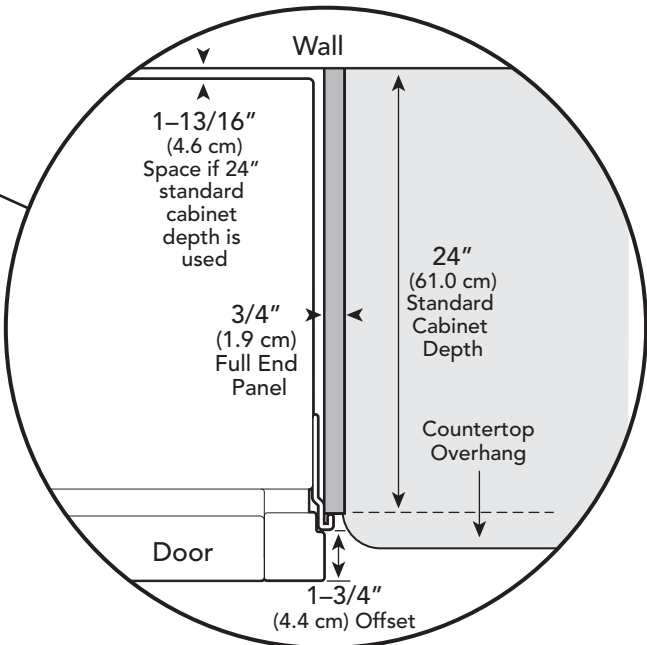

Cabinet Information (Professional with Flush Mount Trim)

Professional models with flush mount trim fit flush in standard 24" (61.0 cm) deep cabinet openings with no protrusion into the room except the handle protrudes 2-1/2" (6.4 cm) into the room.

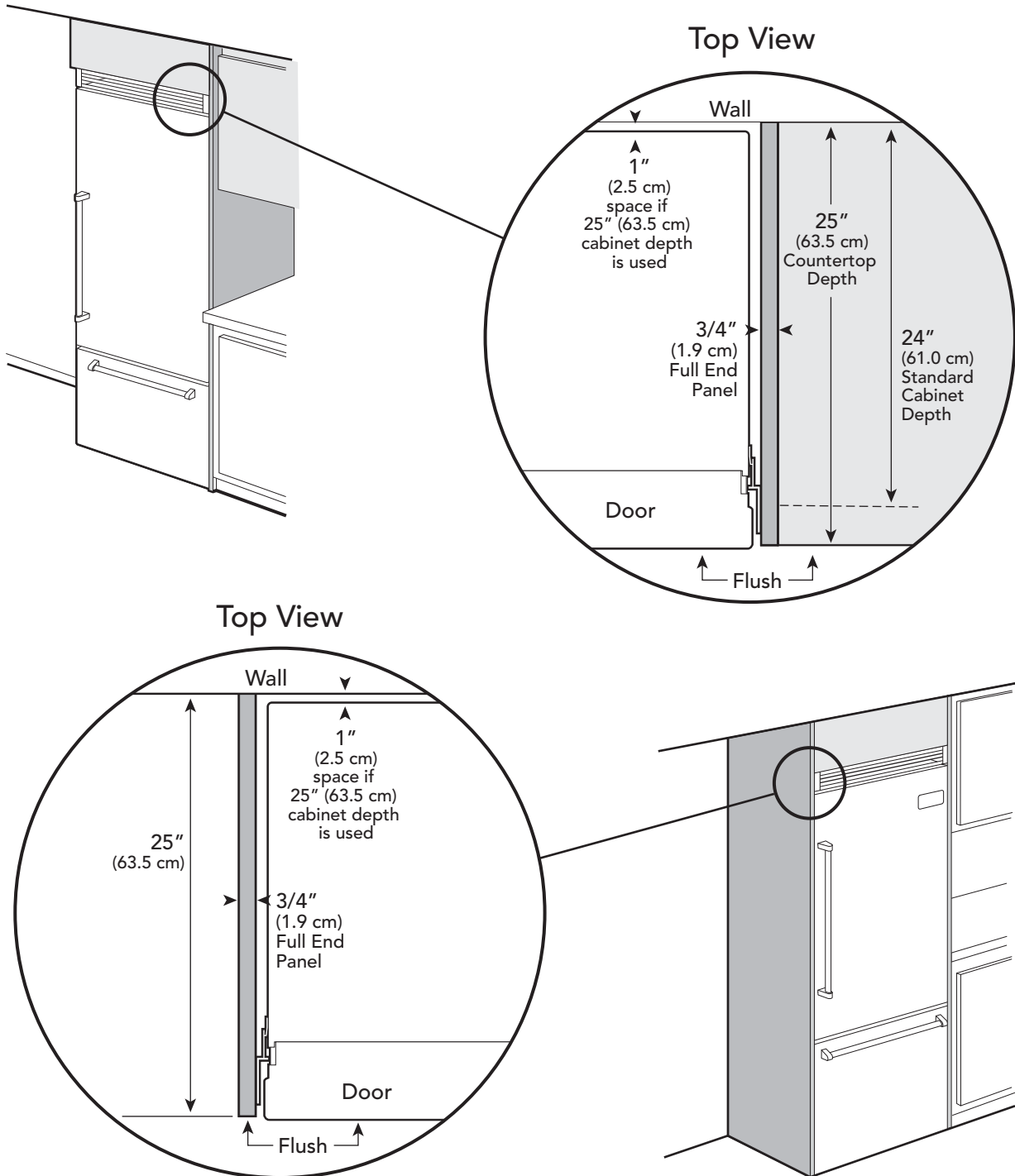

Custom Side Panel Dimensions (Professional)

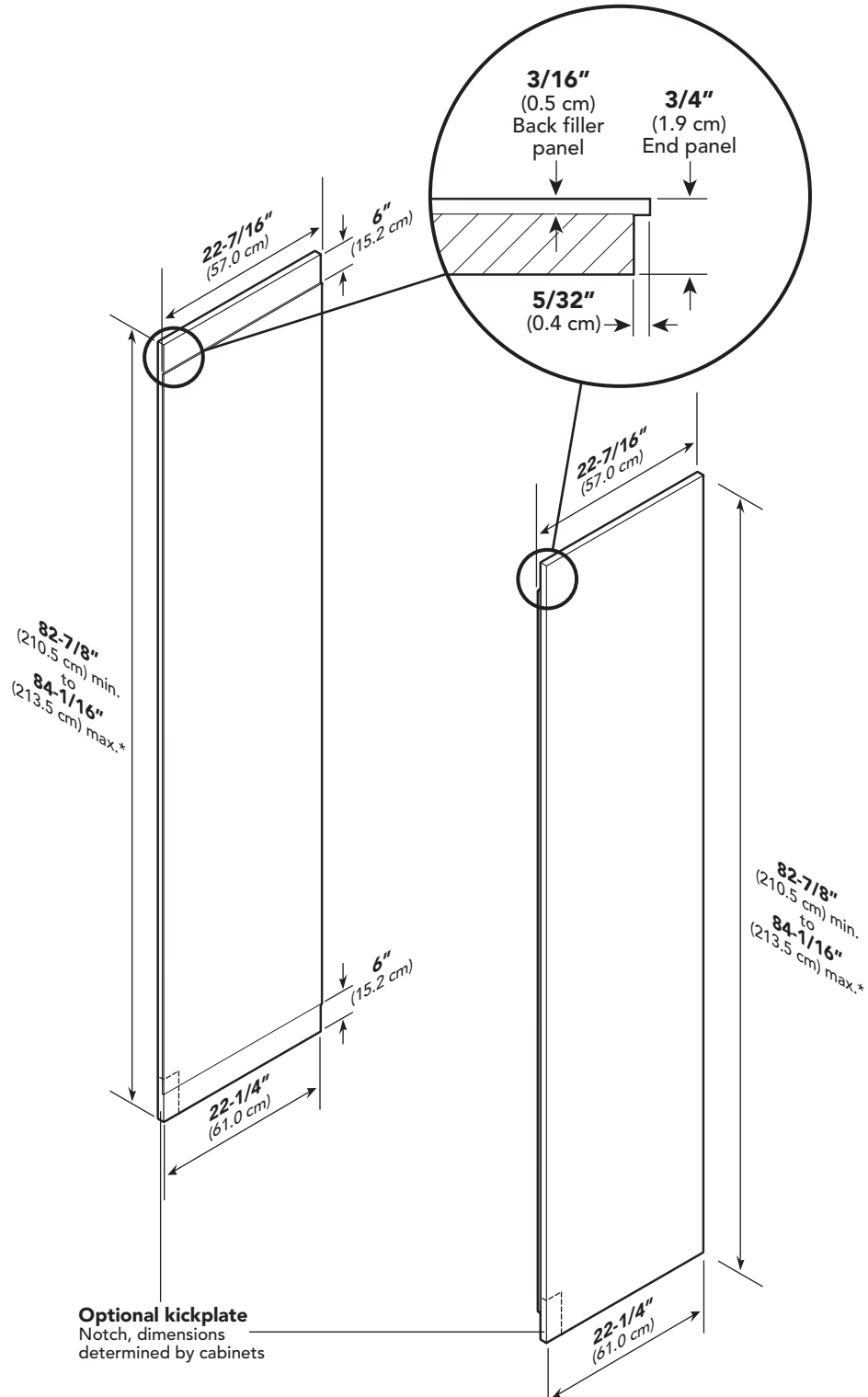

* Depending on how high leveling feet are raised, and cabinet enclosure height.

Custom Side Panel Dimensions

(Professional with Flush Mount Trim)

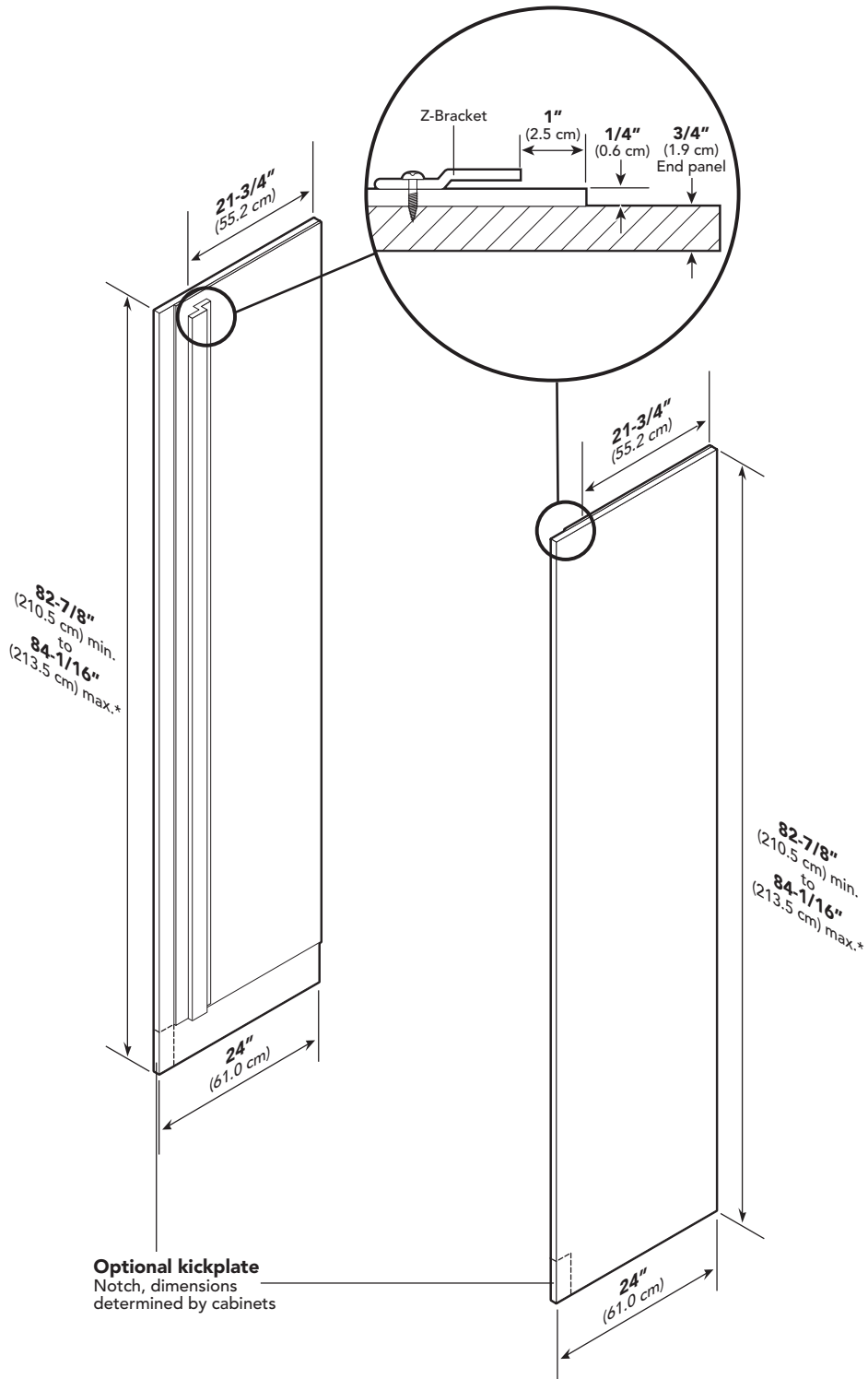

* Depending on how high leveling feet are raised, and cabinet enclosure height.

General Information

Area Requirements

Verify the following:

- Unit can fit into residence and can be moved around corners and through doorways.
- Floors can support unit's weight plus food weight (approximately 1200 pounds [540 kg] per unit).
- Floors underneath refrigerator are level with surrounding finished floor.
- Rear wall is solid and is able to support two horizontally mounted 2 x 4s (included) bolted to two wall studs. The 2 x 4 board bolt heads must be flush with 2 x 4 to prevent obstruction.
- Remove anything attached to rear or side walls that can obstruct unit installation.
- Cutout dimensions are accurate.
- Electrical outlet is in correct location.
- Water line is in correct location.
- **DO NOT** install a refrigeration unit near a heat source, nor in a location where the surrounding temperature will fall below 60° F (16° C).

Electrical Requirements

It is the customer's responsibility to:

- Contact a qualified electrical installer.
- Assure that the electrical installation is adequate and in conformance with the National Electrical Code, ANSI/NFPA 70-latest edition or Canadian Electrical Code C22.1-1998 and C22.2 No. 0-M91 (or latest edition), and all local codes and ordinances.

A 115 volt, 60-Hz, 15 amp, fused, electrical supply is required. It is required that a separate circuit serving only this appliance be provided. This appliance is equipped with a power supply cord having a 3-prong grounding plug. To minimize possible shock hazard, the cord must be plugged into a mating 3-prong, grounding-type wall receptacle. **DO NOT** use an extension cord.

If codes permit a separate grounding wire to be used, it is recommended that a qualified electrician determine that the grounding path is adequate.

DO NOT ground to a gas line. Check with a qualified electrician if you are not sure if the appliance is properly grounded. **DO NOT** have a fuse in the neutral or grounding circuit.

Anti-Tip Requirements

The anti-tip boards should be fastened into position prior to moving the unit into the opening.

Note: *Additional mounting boards may be required if the unit does not touch the back wall of the enclosure. To prevent unit from tipping forward, it must be secured in place with a solid soffit or wood block.*

General Information

Water Supply Requirements

WARNING

To avoid serious illness or death, **DO NOT** use unit where water is microbiologically unsafe or of unknown quality, without adequate disinfection before or after the system. Systems certified for cyst reduction may be used on disinfected water that may contain filterable cysts. The contaminants or other substances removed or reduced by this water treatment system are not necessarily in your water.

CAUTION

Be sure to have a replacement cartridge available when filter change is required.

- If water filtration system has been allowed to freeze, replace filter cartridge.
- If system has not been used in several months, and water has an unpleasant taste or odor, flush system by dispensing 2-3 glasses of water. If unpleasant taste or odor persists, change filter cartridge.

Use only 1/4" (6 mm) copper tubing for water line. DO NOT install copper tubing in area where temperatures drop below 35° F (1.7° C). Before attaching copper tubing to the unit, flush at least 2 quarts (1.9 L) of water through the copper tubing and into a bucket to remove any particles in the water line.

- **Viking Range, LLC is not responsible for property damage due to improper installation or water connection.**
- Connect 1/4" (6 mm) flexible copper tubing to household plumbing in compliance with local codes and ordinances.
- Length of copper tubing must reach from water supply connection to the unit connection with an additional length to facilitate moving the unit out of enclosure

for cleaning or service. Tubing should be soft instead of rigid and ends should be free of burrs.

- Copper tubing route must be above 35° F (1.7° C) to prevent water line from freezing.
- **DO NOT use plastic water lines from the household plumbing to the water inlet valve connection on the refrigeration unit.**
- **DO NOT use the self-piercing feature of a saddle valve.** The hole made by the piercing lance is too small for the water flow rate required by the ice maker.
- If saddle valve is not used, place a separate shut-off valve in an easily accessible location between water supply and the unit. **DO NOT** install shut-off valve behind the unit.
- The installation of Viking units with a reverse osmosis system is acceptable **as long as the water pressure remains within the allowable PSI as stated below.** It is important to note that with many reverse osmosis systems, the pressure starts off high, but then it decreases as the water level of the reverse osmosis storage area drops. This must be considered when checking the water pressure coming into the unit.
- Connect a vertical or horizontal 1/2" (1.3 cm) to 1-1/4" (3.2 cm) COLD water line near water area.
- Run water line through the floor, back, or side wall. Tubing should lay flat on floor underneath the unit. Clamp tubing to wall or floor.
- Water pressure must be greater than 20 psi and less than 120 psi on non-dispensers and greater than 35 psi and less than 120 psi on dispensers.

General Information

Area Requirements

- Most of the unit's weight is at the top. Extra care is needed when moving the unit to prevent tipping.
- **DO NOT** remove protective film until unit is in operating position.
- All four leveling legs must contact the floor to support and stabilize the full weight.
- **DO NOT** drop unit.
- Remove exterior shipping materials prior to moving unit into home, except door latching device.
- Use two or more people to move and install unit. Failure to follow this instruction can result in back or other injury.
- To avoid personal injury, wear gloves when performing any installation procedure and wear eye protection when cutting metal straps.

Tip Over Hazard

Appliance is top heavy and tips easily when not completely installed. Keep doors closed until appliance is completely installed and secured per installation instructions. Use two or more people to move and install appliance. Failure to do so can result in death or serious injury.

Unpacking Unit

1. Remove top and bottom strap.
2. Remove top cap.
3. Cut carton rear approximately 1/4" (0.6 cm) to 1" (2.5 cm) from right corner with a utility knife extended 1/4" (0.6 cm).
4. Remove carton and exterior packaging. Save cardboard shipping material to protect floor surface when installing unit. Remove anti-tip board and kickplate from rear of unit.

Moving Unit

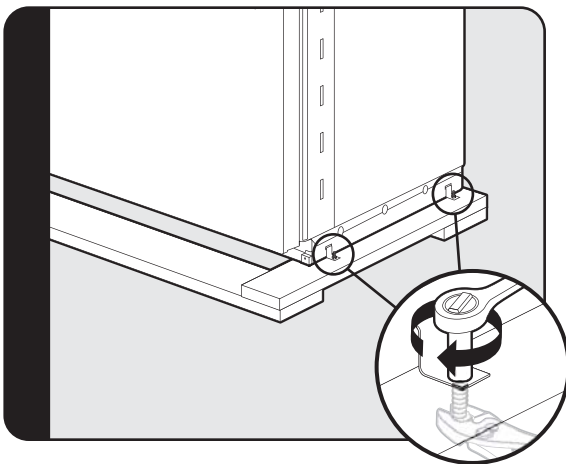

Remove shipping brackets from skid by removing four bolts (two on each side) with a 1/2" (1.3 cm) deep-well socket wrench and a pair of pliers. **Note:** Tilting unit is not required to remove shipping brackets.

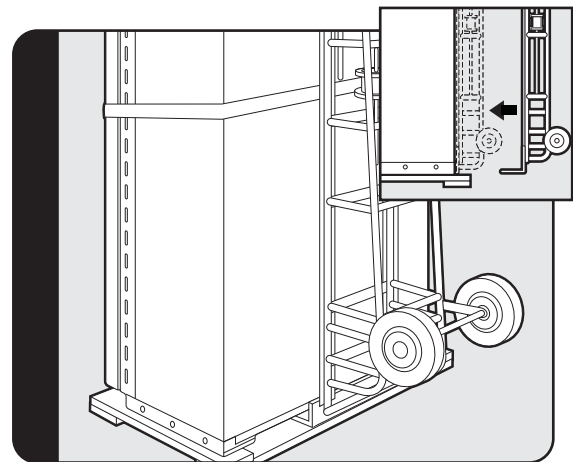

Slip appliance dolly between unit and skid. Remove unit from skid. **Note:** Use excess packaging to protect decorative trim; also, verify that leveling legs are up (0" adjustment).

Flush Mount Side Trim Installation

(Sold Separately)

Note: If the unit is to be installed flush with the cabinets, the flush mount side trim must be installed first. If not, skip to "Installation".

Step 1 - Locate the necessary parts: Two (2) flush mount trim pieces and a hardware kit with twenty-two (22) screws.

Step 2 - Remove the side trim on the refrigerator and discard the trim and screws.

Step 3 - Align the top of the flush mount side trim with the top of the unit's machine compartment. Using the screws included in the hardware kit, attach the side trim to the unit, only using the holes visible through the side trim. **Note: DO NOT** use the screw holes in the machine compartment.

Installation

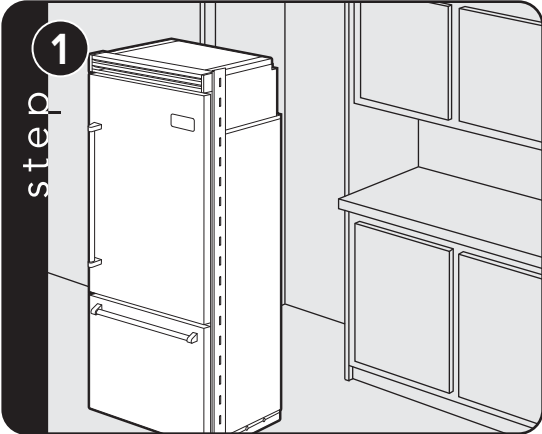

Place unit in front of cutout.

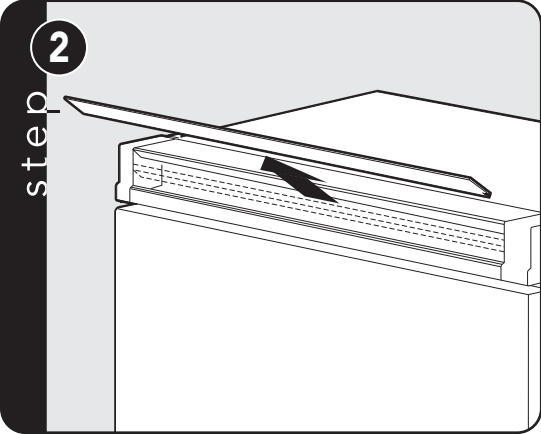

Pull the center grille louver up at an angle and pull out.

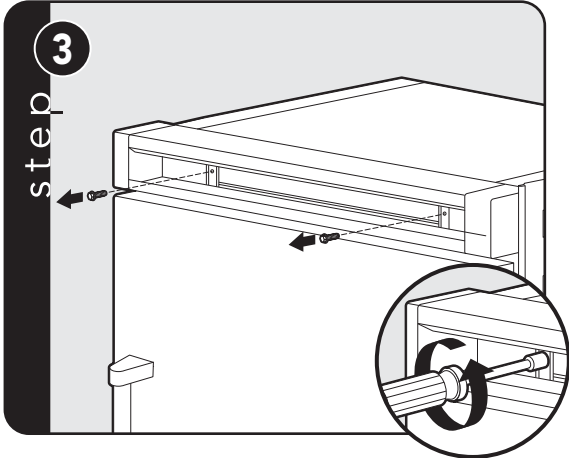

Using an 8" (20.3 cm) magnetic nut driver, remove the two 1/4" (0.6 cm) screws.

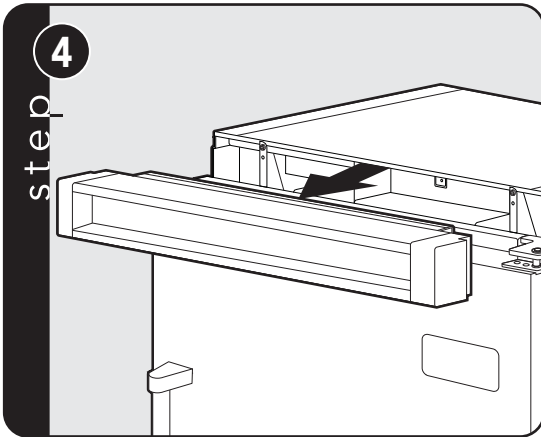

Remove grille assembly.

Hinge Adjustment

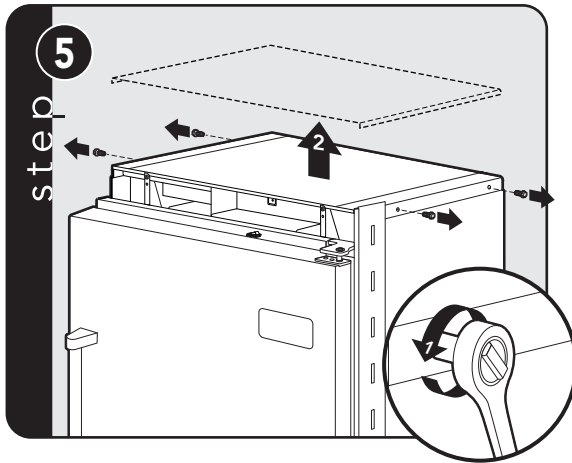

Remove four side screws and remove unit top.

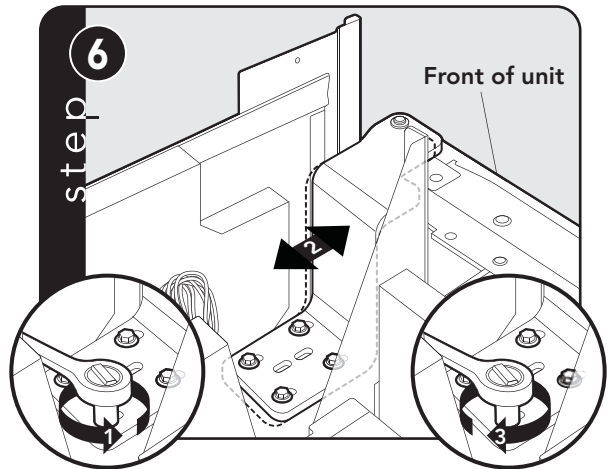

Loosen the four hinge screws. Adjust door.
Retighten four hinge screws.

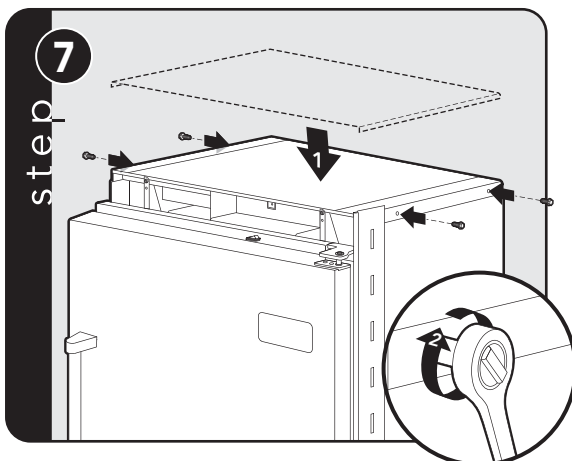

Replace unit top. Replace four side screws.

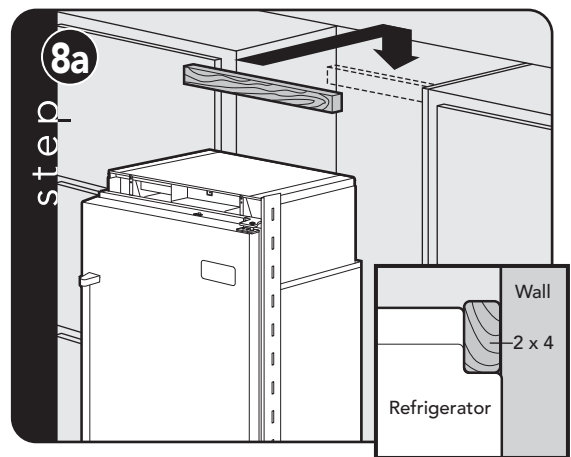

Attach one 2 x 4 to wall stud (refer to dimensions page for exact location).

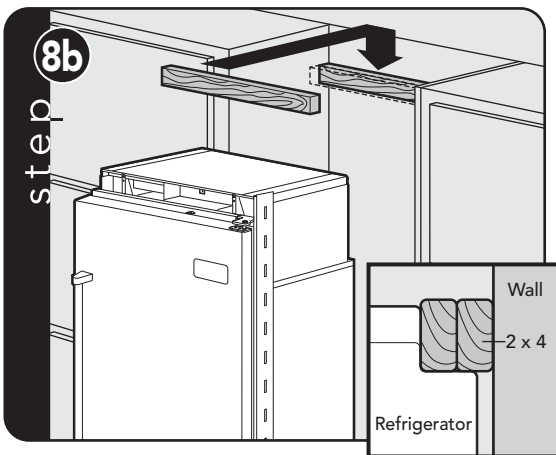

If needed, depending on cabinet and depth, attach second 2 x 4 to first 2 x 4.

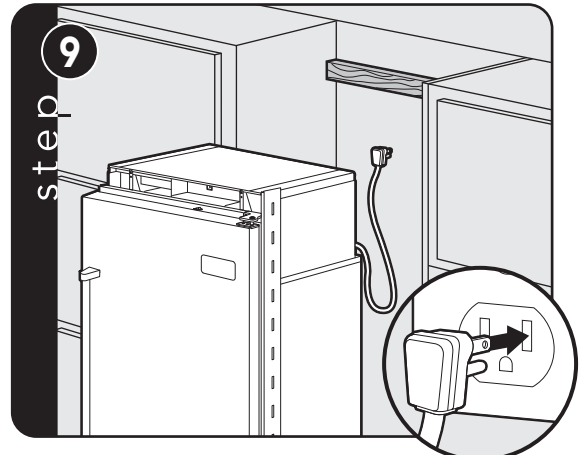

Plug in power cord to verify operation.
Note: Make sure power switch is in the "On" Position.

Hinge Adjustment (cont.)

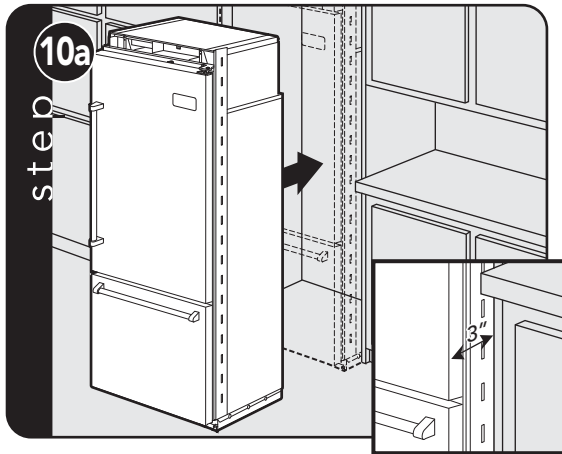

Place unit within 3" (7.6 cm) of being flush with cabinets. **Note:** To avoid cabinet damage, place cardboard between cabinets and unit. When moving unit, **DO NOT** crimp, kink or crush water supply line.

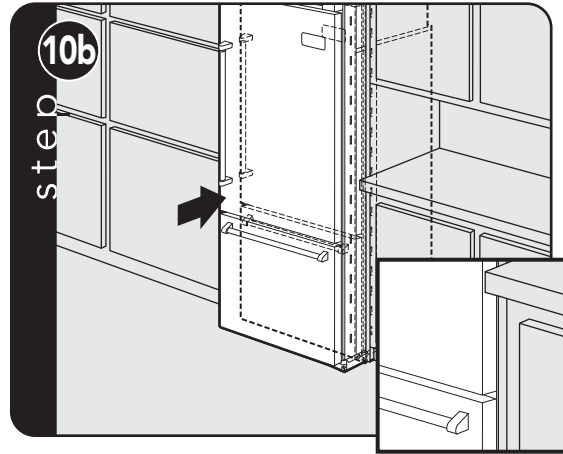

Carefully move unit until semi flush with cabinet (depending on unit).

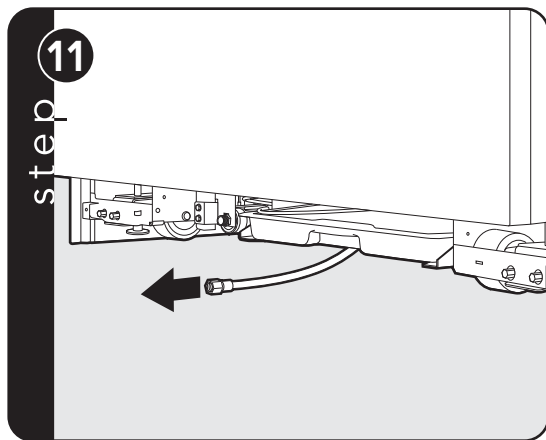

Pull supply tubing forward under unit. **Note:** **DO NOT** use plastic water lines.

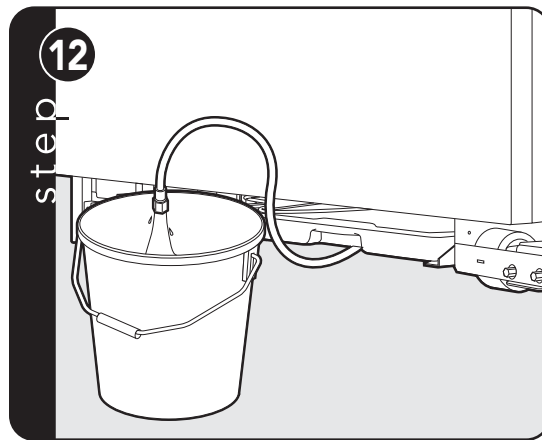

Flush water line by running two quarts of water into a bucket. Turn water off.

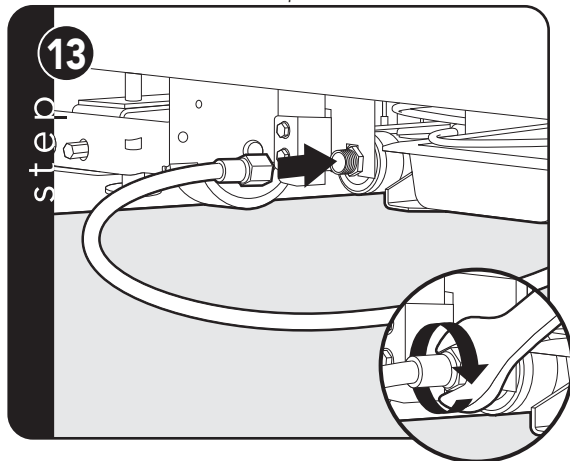

Connect supply tube to water valve using a 1/2" wrench. **Note:** **DO NOT** overtighten.

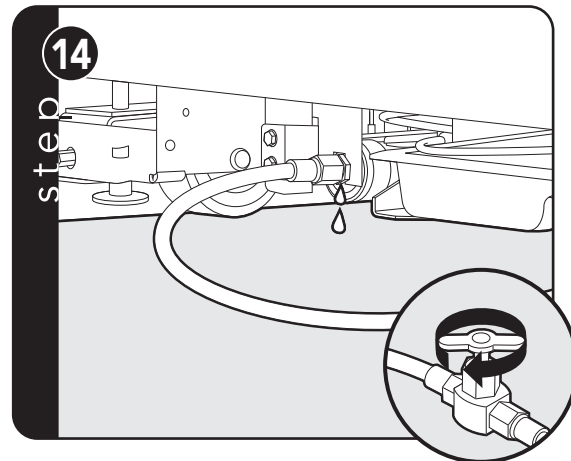

Turn on water supply and check for leaks.

Hinge Adjustment (cont.)

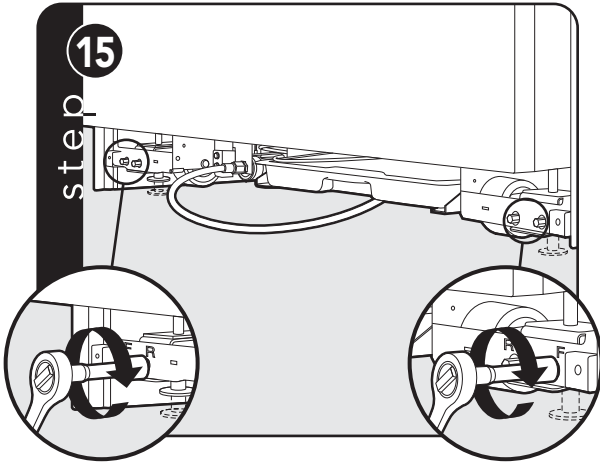

Lift unit off rollers to desired height and level unit using a 5/16" head wrench. NOTE: DO NOT use an electric device. Overtightening can cause damage.

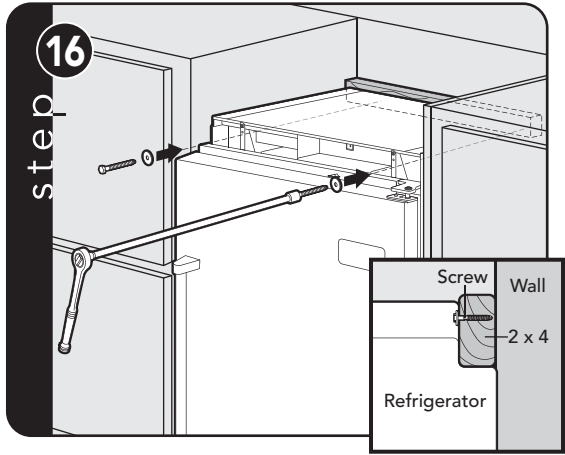

Reinstall handle side door trim and door trim screws.

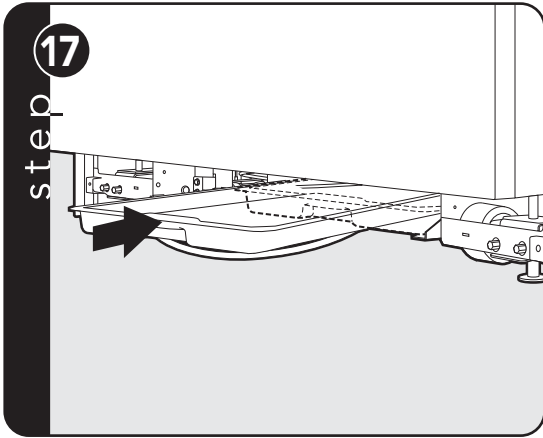

Reinstall cabinet trim and screws.

Kickplate Installation

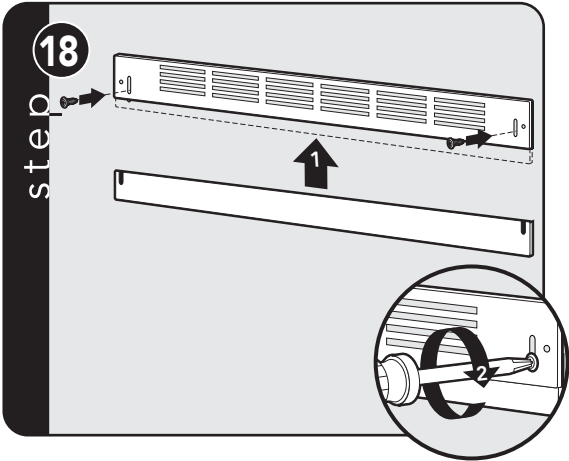

Align holes on both ends of louvered panels and insert screws.

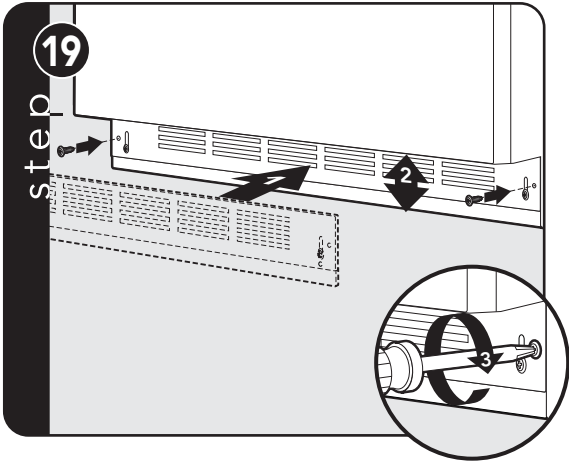

Using a Phillips screwdriver, attach the kickplate to the unit and adjust to desired height.

Door Stop Adjustment (Bottom-Freezer)

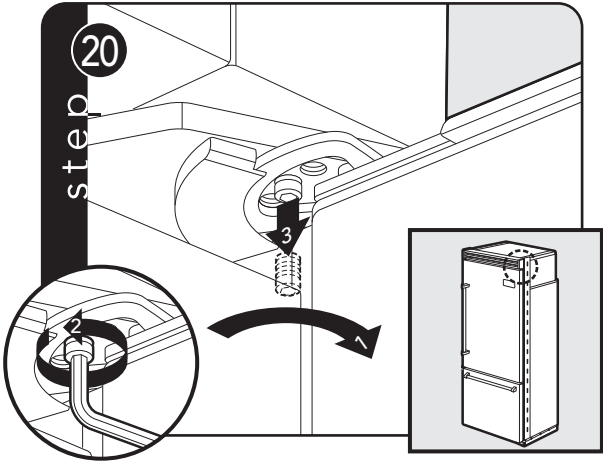

Open refrigerator door so door stop and shoulder screw are accessible. **Note:** Shoulder screw should be in 110° door opening position.

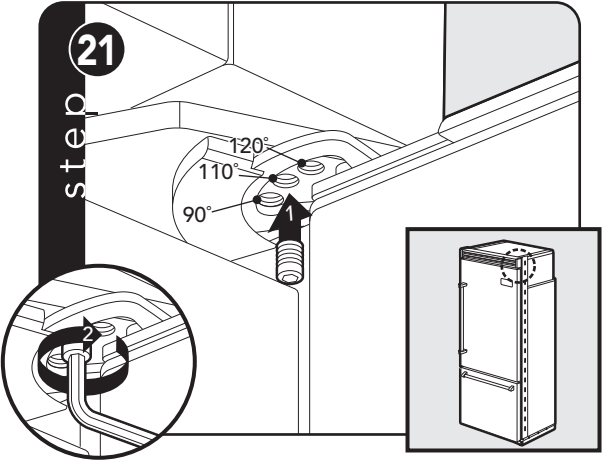

Remove shoulder screw and place in 90° or 120° position.

Water Filter System Specification and Performance Data Sheet

This system has been tested according to NSF/ANSI 42/53 for reduction of the substances listed below. The concentration of the indicated substances in water entering the system was reduced to a concentration of less than or equal to the permissible limit for water leaving the system, as specified in NSF/ANSI 42/53.* (100% safety factors built-in for unmetered usage for health claims only.)

Contaminant Reduction	Average Influent	NSF Specified Challenge Concentration	Avg % Reduction	Average Product Water Concentration	Max Permissible Product Water Concentration	NSF Reduction Requirements	NSF Test Report
Chlorine Taste and Odor	2.0 mg/L	2.0 mg/L \pm 10%	97.5%	0.05 mg/L	N/A	\geq 50%	J-00056501
Nominal Particulate Class I, \geq 0.5 to < 1.0 μ m	13,666,667 pts/mL	At least 10,000 particles/mL	98.9%	143,333 pts/mL	N/A	\geq 85%	J-00056506
Asbestos	96 MF/L	10 ⁷ to 10 ⁸ fibers/L; fibers greater than 10 μ m in length	>99%	<1 MF/L	N/A	\geq 99%	J-00056511
Atrazine	0.010 mg/L	0.009 mg/L \pm 10%	89.3%	0.001 mg/L	0.003 mg/L	N/A	J-00056512
Cyst*	122,500 cysts/L	Minimum 50,000 cysts/L	99.99%	1 cyst/L	N/A	\geq 99.95%	J-00056513
Lead @ pH 6.5	0.153 mg/L	0.15 mg/L \pm 10%	99.3%	0.001 mg/L	0.010 mg/L	N/A	J-00056515
Lead @ pH 8.5	0.150 mg/L	0.15 mg/L \pm 10%	99.3%	0.001 mg/L	0.010 mg/L	N/A	J-00058784
Lindane	0.002 mg/L	0.002 mg/L \pm 10%	97.8%	0.00004 mg/L	0.0002 mg/L	N/A	J-00058969
Mercury @ pH 6.5	0.006 mg/L	0.006 mg/L \pm 10%	95.0%	0.0003 mg/L	0.002 mg/L	N/A	J-00058785
Mercury @ pH 8.5	0.006 mg/L	0.006 mg/L \pm 10%	88%	0.0007 mg/L	0.002 mg/L	N/A	J-00058783
Toxaphene	0.015 mg/L	0.015 mg/L \pm 10%	93.2%	0.001 mg/L	0.003 mg/L	N/A	J-00056531
Turbidity	10.8 NTU	11 \pm 1 NTU	98.7%	0.153 NTU	0.5 NTU	N/A	J-00058972

*Based on the use of *Cryptosporidium parvum* oocysts

Operating Specifications

Capacity: Certified for up to 750 gallons (2,838 L); up to nine months
 Pressure Requirement: 20 - 120 psi (1.4 - 8.2 bar)
 Temperature: 33-100° F (0.6 - 37.8° C)
 Flow rate: 0.78 gpm (2.9 l/min.)

Check for compliance with the state and local laws and regulations.

Note: While the testing was performed under standard laboratory conditions, actual performance may vary.

Must be installed and operated in accordance with manufacturer's recommended procedures and guidelines. Installation instructions, parts and service availability, and standard warranty are included with the product when shipped. This drinking water system must be maintained according to manufacturer's instruction, including replacement of filter cartridges.

Manufactured by: 3M Purification Inc.
 400 Research Parkway
 Meriden, CT 06770

System tested and certified by NSF International against Standard 42 for the reduction of chlorine taste and odor, particulate Class I and Standard 53 for the reduction of Lead, Lindane, Atrazine, Mercury, Toxaphene, Cyst, Turbidity, and Asbestos.



Final Installation

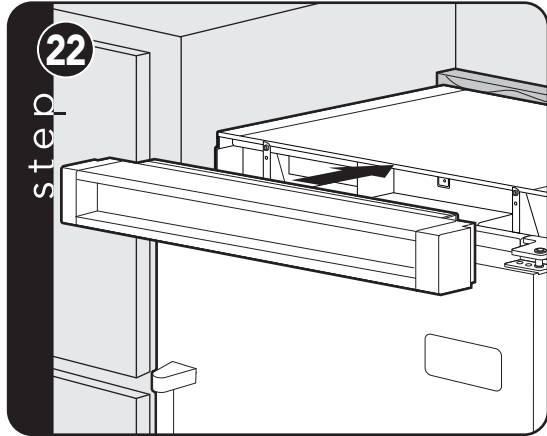

Replace top air grille.

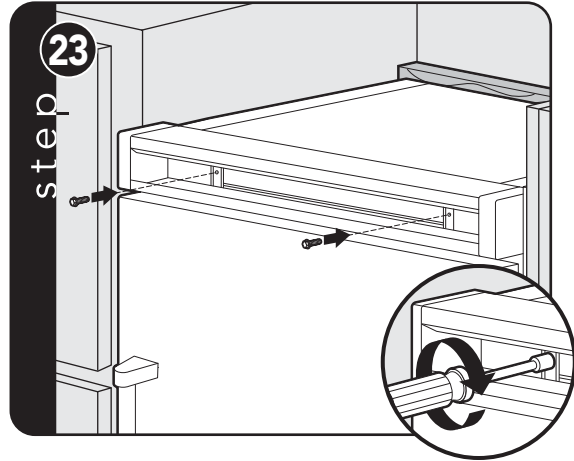

Using an 8" (20.3 cm) magnetic nut driver, replace the two 1/4" (0.6 cm) screws.

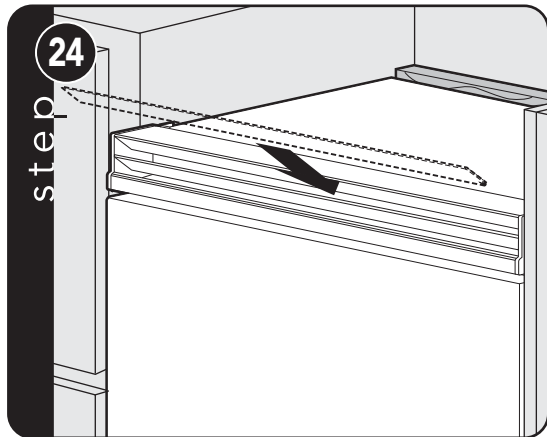

Replace the center grille louver.

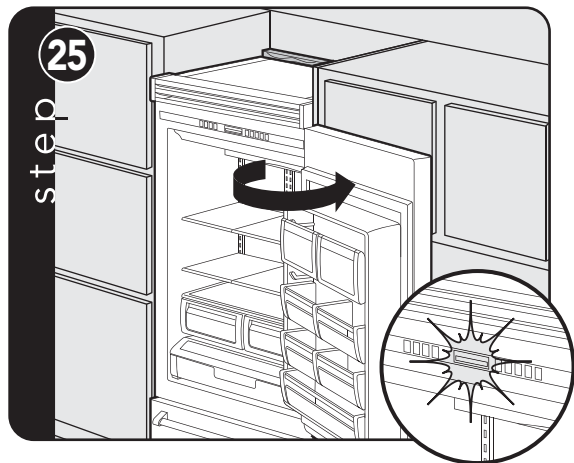

Open door. The display should flash.

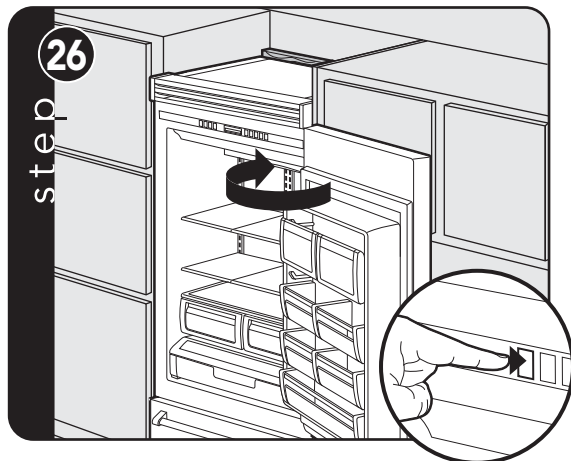

Press "ACTIVATE CONTROLS" pad and close door. **Note:** There is a 6 minute delay before the unit starts.

Performance Checklist



- Verify cabinet size.
- Verify electrical supply and water supply (if applicable).
- Install anti-tip device(s) and verify unit is secure.
- Position unit in cutout, level at desired height and secure unit.
- Plug-in unit and verify operation.
- Connect water supply (if applicable).
 - Verify icemaker fill tube is properly inserted.
 - Verify icemaker bail arm is down.
 - Verify dispenser operation (if applicable).

- Align/square door(s).
- Verify drain pan is properly installed and there are no leaks on water connection.
- Install kickplate.
- Remove internal packaging and labels and wipe unit down.

Installer's information:

Installer's name: _____

Installer's company: _____

Date: _____

Verify Operations

Control Panels

Bottom Freezer

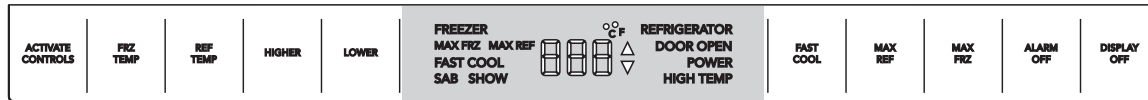

1. Press "ACTIVATE CONTROLS" pad.
2. Verify unit is not in Sabbath Mode.
If in Sabbath Mode:
 - A. The Sabbath Mode will disable the interior lights, display (except SAB indicator, temperature and compartment indicator) and alarm.
To exit the Sabbath Mode:
 - B. Press and hold "ACTIVATE CONTROLS" and then "DISPLAY OFF" for 3 seconds. (The control will beep three times to alert the user the Sabbath Mode has been exited.)
3. Verify unit is not in Showroom Mode.
If in Showroom Mode:
 - A. The Showroom Mode will disable the refrigerator system but all other functions are normal. These include lights and control. (If the refrigerator is in Showroom Mode, SHOW will be lit.)
To exit Showroom Mode:
 - B. Press and hold "ACTIVATE CONTROLS"; while holding, press and hold "HIGHER" and "ALARM OFF" together. (The control will beep three times to alert the user that Showroom Mode has been exited.)
4. Press "ACTIVATE CONTROLS" then press and hold "LOWER"; while holding, press and hold "DISPLAY OFF" and hold until beeps (force start compressor).
5. All models need to be set at 38° F and 0° F for the refrigerator and freezer respectfully - factory setting.

Service & Registration

If service is required, call your dealer or authorized service agency. The name of the authorized service agency can be obtained from the dealer or distributor in your area.

Have the following information readily available.

- Model number
- Serial number
- Date purchased
- Name of dealer from whom purchased

Clearly describe the problem that you are having. If you are unable to obtain the name of an authorized service agency, or if you continue to have service problems, contact Viking Range, LLC at 1-888-(845-4641), or write to:

**VIKING RANGE, LLC
PREFERRED SERVICE
111 Front Street
Greenwood, Mississippi 38930 USA**

Record the following information indicated below. You will need it if service is ever required.

The serial number and model number for your appliance are located on the identification plate mounted behind the top light.

Record the information indicated below. You will need it if service is ever required.

Model number _____

Serial number _____

Date of purchase _____

Date installed _____

Dealer's name _____

Address _____

If service requires installation of parts, use only authorized parts to insure protection under the warranty.

KEEP THIS MANUAL FOR FUTURE REFERENCE.

Viking Range, LLC
111 Front Street
Greenwood, Mississippi 38930 USA
(662) 455-1200

For product information,
call 1-888-(845-4641)
or visit our web site at vikingrange.com in the US
or brigade.ca in Canada

